

OG. FLUID

*Fluid passion
Leidenschaft für Hydraulik*

VALVE SYSTEMS

VENTIL SYSTEME



GFV013-13-03

**Natural laws define how our valves function.
Ethical values give our work meaning.**

The function and use of our valves are defined by clear technological and economic concepts.

Customer-specific parameters, shorter innovation and production cycles, company-wide quality management, just-in time, lean production and cost controlling are the most important parts of our philosophy.

However, the above are just empty words without the commitment of motivated **people**.

It is our aim to cultivate a community of minds in our company in which all employees can freely develop their personality and their skills.

With the objective of achieving service-oriented behavior and entrepreneurial thinking in order to realize a genuine, responsible relationship with **customers**, suppliers and **among each other**.

*G. FLUID
Fluid passion*

**Naturgesetze definieren, wie unsere Ventile funktionieren.
Ethische Werte geben unserer Arbeit Sinn.**

Funktion und Anwendung unserer Ventile sind durch klare technologische und wirtschaftliche Konzepte definiert.

Kundenspezifische Parameter, kürzere Innovations- und Produktionszyklen, firmenumfassendes Qualitätsmanagement, schlanke just-in-time-Produktion und Kostenkontrolle sind die tragenden Säulen unserer Firmenphilosophie.

Ohne das Engagement motivierter **Mitarbeiter** sind das jedoch nichts als leere Worte.

Unser Ziel ist es, in unserer Firma Wissen anzusammeln und allen Mitarbeitern die Möglichkeit zu geben, ihre Persönlichkeit und ihre Fähigkeiten frei zu entwickeln.

Mit der Zielsetzung, kundenorientiert zu arbeiten und durch unternehmerisches Denken eine ehrliche, verantwortungsvolle Beziehung zu unseren **Kunden**, Lieferanten und **untereinander** aufzubauen.

*G. FLUID
Leidenschaft für Hydraulik*

	Page Seite
Index - Inhaltsverzeichnis	0.00.01-1
Warranty and limitation of liability- Garantie und Haftungsgrenzen	0.00.02-1
General terms of sales - Allgemeine Verkaufsbedingungen	0.00.02-3
Filtration requirements - Filterfeinheit	0.00.02-5
Recommended viscosity - Empfohlene Viskosität	0.00.02-6
Materials - Materialien	0.00.02-7
Index by valve type - Inhaltsverzeichnis nach Ventiltyp	0.01.01-1
Index by code - Inhaltsverzeichnis nach Artikelnr.	0.01.02-1
Pressure control - Druckventile	1.000.01
Motion control valves - Schwenkbrems-Sperrventile	2.000.01
Flow control valves - Stromregel- und Drosselventile	3.000.01
Regenerative valves - Eilgangsventile	4.000.01
Valves for single-acting cylinders - Kontrollventile für Einfachzylinder	5.000.01
Hydrostatic transmission valves - Ventile für hydraulische Fahrtriebe	6.000.01
Valves for earth moving machines - Ventile für Baumaschinen	7.000.01
Electro-proportional valves - Elektroproportionalventile	8.000.01
Sandwich valves - Zwischenplattenventile	9.000.01
Special valves - Sonderventile	10.000.01
Conversion - Masseinheiten	Z.01.01-1
Other catalogues – Weitere Kataloge	Z.02.01-1

All products are warranted for a period of 12 (twelve) months from date of shipment from seller's plant to be free from defects in material and workmanship under:

- **Correct use**
- **Normal operating conditions**
- **Proper application**

Seller's obligation under this warranty shall be limited to the repair or exchange, at seller's option, ex - factory, of any seller's product or part which proves to be defective as provided herein.

The buyer has to verify within 7 days of receipt of the goods delivered by G.Fluid that the received goods correspond to the ordered items. Once 7 days are passed by, G.Fluid is not responsible for any evident defect.

Replacement of goods: Buyer has to pay the transport. The seller reserves the right to either inspect the product at buyer's location or require it to be returned to the factory for inspection (carriage paid). The goods have to be packed in the same way they were when the buyer received them.

The above warranty does not extend to goods damaged, or subjected to accident, abuse or misuse after shipment from seller's factory, nor to goods altered or repaired by anyone other than authorized by seller's representatives.

The G.Fluid actions connected to the described warranty will be done within 7 days from the result of the inspection that will have determined defective material or machining (while part was used correctly, in proper conditions and with correct technical installation) of the sold goods.

There are no express warranties other than those which are specifically described herein.

Any description of the goods sold hereunder, including any reference to buyer's specifications and any description in catalogues, circulars and other written material published by seller, is for the sole purpose of identifying such goods and shall not create an express warranty that the goods shall conform to the sample or model.

Buyer is solely responsible for determining the suitability of goods sold hereunder for use of buyer.

There are no implied warranties of merchantability or fitness for a particular purpose.

In no case the seller is responsible for damages connected to sold parts regarding the aspect, the use, the installation or the function.

Seller will not even be liable for any incidental or consequential damage whatever, nor for any sum in excess of the price received for the goods for which liability is claimed.

Seller reserves the right to discontinue, modify or revise the specifications or the products described herein.

All specifications are approximate and may vary depending upon installation.

Für eine Dauer von 12 (zwölf) Monaten ab dem Versanddatum gewährt die Verkaufsfirma unter folgenden Bedingungen Garantie gegen Material- oder Verarbeitungsfehler:

- **korrekte Anwendung**
- **normale Betriebsbedingungen**
- **technisch geeignete Installation**

Die Garantie beschränkt sich auf die Reparatur oder den Umtausch jeglicher Artikel oder deren Teile, an denen von der Verkaufsfirma der Mangel gemäß oben genannter Bedingungen festgestellt worden ist.

Der Käufer muss innerhalb von 7 Tagen nach Erhalt der durch G.Fluid gelieferten Ware überprüfen, dass diese auch tatsächlich der bestellten Ware entspricht. Nach Ablauf dieser Frist kann G.Fluid für offensichtliche Mängel nicht mehr verantwortlich gemacht werden. Umtausch von Waren: Transportkosten müssen vom Käufer getragen werden

Die Verkaufsfirma behält sich das Recht vor, das Produkt zu überprüfen und nach eigenem Ermessen zu entscheiden, ob dies beim Kunden oder im eigenen Werk erfolgen wird (Artikel muss vom Kunden frei Haus zurückgesandt werden).

Die oben genannte Garantie gilt nicht für Produkte, die nach dem Versand beschädigt worden sind, sowie für geänderte oder reparierte Produkte, wenn nicht ausdrücklich von der Herstellerfirma zuvor genehmigt.

G.Fluid wird seinen Pflichten, die mit der hier beschriebenen Garantie in Zusammenhang stehen, spätestens in 7 Tagen nach dem Ergebnis der Überprüfung des zurückgesandten Produkts nachkommen (wenn sich bestätigt, dass es sich um defektes Material oder fehlerhafte Produktion bei korrekter Anwendung und Montage handelt).

Es gibt keine andere Garantief orm als die hier genannte.

Datenblätter, die in Katalogen, Newsletters oder anderem von der Verkaufsfirma veröffentlichten Material erscheinen, dienen nur der Beschreibung der Produkte und garantieren nicht, dass diese auch exakt entsprechen. Die Verantwortung dafür, dass ein bestimmtes Produkt für eine bestimmte Anwendung geeignet ist, liegt ausschließlich beim Käufer.

Die Verkaufsfirma haftet nicht für Schäden, die durch die Benutzung der von ihr verkauften Produkte betreffend Aussehen, Anwendung, Montage und Vertrieb seitens des Käufers hervorgerufen werden.

Keinesfalls ist die Verkaufsfirma für zufällige Schäden oder Folgeschäden, die nicht in direktem Zusammenhang mit dem Produkt stehen, haftbar zu machen.

Die Verkaufsfirma behält sich vor, die beschriebenen Produkte und deren Eigenschaften zu streichen, zu ändern oder durchzusehen. Alle Details sind Richtwerte und können je nach Montage Schwankungen unterliegen.

Per un periodo di 12 (dodici) mesi dalla data di spedizione dal proprio stabilimento, la ditta venditrice garantisce i propri prodotti contro difetti, di materiale o di lavorazione, verificatisi in condizioni di

- **corretto uso**
- **normali condizioni d'esercizio**
- **installazioni tecnicamente adatte**

La garanzia è limitata alla riparazione o alla sostituzione, a giudizio della venditrice, di qualsiasi articolo, o parte di esso, di cui con i criteri suddetti, sia stato contestato il difetto.

Il compratore ha l'obbligo di verificare, entro sette giorni dal ricevimento della merce consegnata da G.Fluid, la corrispondenza tra quanto ordinato e quanto ricevuto e G.Fluid non sarà tenuta, decorso inutilmente tale termine, ad alcun tipo di responsabilità in caso di vizi o difetti palesi della merce ordinata e consegnata.

La sostituzione avverrà in porto assegnato.

La venditrice si riserva il diritto di ispezionare il prodotto a sua scelta, sia presso l'acquirente che nel proprio stabilimento, richiedendo, se del caso, che il pezzo le sia spedito in porto franco e nelle medesime condizioni di imballaggio che il prodotto aveva quando è stato ricevuto.

La suddetta garanzia non è estesa ad articoli danneggiati o manipolati dopo la spedizione dalla fabbrica, né a quelli modificati o riparati da chiunque non sia espressamente autorizzato dalla venditrice.

Gli obblighi della G.Fluid, connessi alla descritta garanzia, saranno eseguiti entro sette giorni dall'esito dell'ispezione che avrà accertato difetti di materiale o di lavorazione in condizioni di corretto uso, normali condizioni d'esercizio e installazioni tecnicamente adatte dei prodotti venduti.

Non esistono altre forme di garanzia che quella sopra citata.

Qualsiasi descrizione dei prodotti venduti, incluse le caratteristiche espressamente richieste dall'acquirente, così come quelle che appaiono su cataloghi, circolari ed altro materiale pubblicato dalla venditrice al solo scopo di identificazione del prodotto, non crea una esplicita garanzia di rispondenza del prodotto alla descrizione stessa. La conformità degli articoli acquistati all'uso che l'acquirente intende farne è esclusiva pertinenza dell'acquirente. In nessun caso la venditrice dovrà essere ritenuta responsabile per danni collegati all'uso di parti da essa vendute per quanto riguarda l'aspetto, la rispondenza all'utilizzazione, l'installazione o funzionamento da parte dell'acquirente. In ogni caso, la venditrice non sarà responsabile per danni accidentali o consequenziali se non nei limiti del corrispettivo percepito per gli articoli per i quali è provata la responsabilità.

La venditrice si riserva il diritto di cessare, modificare o rivedere i prodotti descritti o le loro caratteristiche. Tutti i dati sono di massima e possono variare a seconda dell'installazione.

OFFER / ORDER

Our offers are not binding. Any verbal or phone negotiation shall not be binding for the parties. The contract is concluded with our order confirmation.

All orders shall be in written form and shall show the following information:

- a. date and place where the order is issued;
- b. full name, address and company data of the purchasing company;
- c. signature of a legal representative, with indication of her/his qualification;
- d. reference to an offer (when applicable);
- e. complete G.Fluid ordering code and description of the ordered goods;
- f. quantity;
- g. requested delivery time;
- h. forwarder

The order will be considered valid at G.Fluid delivery and sales terms.

Any subsequent modification of the order confirmation has to be made in written form and is binding only if the consignee accepts it in written form.

PRICES AND PAYMENTS

The quotations are to be understood net, ex works, excl. packing. In case of increase of raw materials and/or of labour, we reserve the right to adjust our prices. Payments shall be made according to agreed terms (see order confirmations). Any extension of the agreed terms shall have to be expressly accepted by G.Fluid in written form.

DELIVERY TERMS

Delivery terms are not to be considered essential.

G.Fluid has to inform the customer of any postponement of the delivery term that exceeds 14 (fourteen) days without any charges. Anyway, in no case G.Fluid shall be held responsible for direct damages due to the non compliance with delivery terms.

RESERVATION OF PROPRIETARY RIGHTS

All our products are sold with reservation of property rights. So, until the invoices are not completely paid, the products are G.Fluid property (art. 1523, Civil Law Code).

RESPONSIBILITY FOR TRANSPORT

All risks arising from the transport of goods are exclusively borne by the customer, even if goods are delivered free to destination.

PLACE OF JURISDICTION

Any disputes between the parties arising from the execution and interpretation of these terms of sales will exclusively fall within the competence of the Court of Modena (Italy).

QUANTITY DISCOUNT

Discounts for big quantities can be inquired at the sales department.

ANGEBOT / BESTELLUNG

Unsere Angebote sind nicht verbindlich. Eventuelle Vereinbarungen mündlicher bzw. telefonischer Art gelten für beide Parteien als Grundlage für den Kaufvertrag, welcher jedoch erst nach ausdrücklicher Zustimmung des Käufers zu den allgemeinen Verkaufsbedingungen und durch eine Auftragsbestätigung des Verkäufers rechtskräftig wird. Die Bestellungen bedürfen der Schriftform und müssen folgende Angaben aufweisen:

- a. Ausstellungsdatum und -ort;
- b. Korrekte Firmenbezeichnung des Käufers mit kompletter Adresse und Firmendaten;
- c. Unterschrift des verantwortlichen Sachbearbeiters mit Angabe der Qualifikation;
- d. Bezug auf ein vorangegangenes Angebot (wenn vorhanden);
- e. vollständige G.Fluid-Bestellnummer und Artikelbezeichnung;
- f. Mengenangaben;
- g. gewünschter Liefertermin;
- h. Spediteur

Die Bestellungen unterliegen den allgemeinen Lieferbedingungen von G.Fluid. Eventuelle Änderungen der Auftragsbestätigung müssen in schriftlicher Form erfolgen und sind erst dann bindend, wenn der Empfänger die Änderungen schriftlich akzeptiert hat.

PREISE UND ZAHLUNGEN

Die Preise verstehen sich netto, ab Werk, excl. Verpackung. Bei Preissteigerungen des Rohstoffes und/oder der Arbeitskräfte behält sich G.Fluid das Recht vor, die Preise anzupassen. Die Zahlung muss innerhalb des von beiden Parteien vereinbarten Zahlungszieles erfolgen (siehe Auftragsbestätigung). Verlängerungen des Zahlungszieles bedürfen der ausdrücklichen schriftlichen Bestätigung durch G.Fluid.

LIEFERZEITEN

Unsere Lieferzeiten sind nicht bindend. Über Lieferverzögerungen, die mehr als 14 Tage betragen, muss G.Fluid den Kunden informieren. G.Fluid kann für Lieferverzögerungen nicht mit Vertragsstrafen belastet werden. In keinem Fall kann G.Fluid für direkte Schäden haftbar gemacht werden, die sich aus der Nichteinhaltung der Lieferfristen ergeben.

EIGENUMSVORBEHALT

Erfolgt die Zahlung des Preises nicht gleichzeitig mit der Auslieferung der Ware, behält sich G.Fluid das Eigentum der Ware vor. Demzufolge erlangt der Käufer das Eigentumsrecht erst nach vollständiger Bezahlung des Preises, obwohl die Haftung für die Ware ab der Lieferung dem Käufer obliegt.

TRANSPORTHAFTUNG

Die Risiken der Warentransporte gehen ausschließlich zu Lasten des Käufers, auch wenn die Lieferung frei Haus erfolgen sollte.

GERICHTSSTAND

Alle Streitfragen, die sich durch die Ausführung oder Auslegung der vorliegenden Verkaufsbedingungen ergeben sollten, unterliegen ausschließlich dem Sitz des Amtsgerichtes von Modena (Italien). MENGENRABATTE Mengenrabatte sind im Verkauf zu erfragen.

OFFERTA/ORDINE

Le ns. offerte non sono vincolanti. Nessuna negoziazione, verbale o telefonica, sarà ritenuta vincolante per le due parti, ma il contratto sarà concluso con la ns. conferma d'ordine.

Gli ordini devono pervenire in forma scritta e devono riportare le seguenti indicazioni:

- a data e luogo di emissione dell'ordine
- b esatta denominazione della società acquirente con indirizzo completo e dati fiscali
- c sottoscrizione di un suo legale rappresentante con indicazione della relativa qualifica
- d riferimento al numero offerta se avvenuta
- e ns. codice di ordinazione completo e descrizione della merce ordinata
- f numero di pezzi
- g termine indicativo di consegna
- h vettore

L'ordine è da ritenersi valido alle condizioni generali di fornitura G.Fluid.

Qualsiasi successiva modifica alla conferma d'ordine deve avvenire in forma scritta e sarà vincolante solo a condizione che venga accettata in forma scritta dal destinatario della modifica.

PREZZI E PAGAMENTO

Le quotazioni sono da intendere nette, franco fabbrica, escluso l'imballo e il trasporto.

Nel caso di aumento della materia prima e/o del costo del lavoro, ci riserviamo il diritto di modificare i prezzi.

I pagamenti devono rispettare tutte le condizioni ed i termini indicati nella conferma d'ordine.

Ogni richiesta di modifica su condizioni e termini di pagamento e relativa accettazione deve avvenire in forma scritta perché possa ritenersi vincolante.

TERMINI DI CONSEGNA

I termini di consegna non sono da considerarsi essenziali.

G.Fluid deve informare il cliente di posticipi di fornitura sopra i 14 giorni senza nessun ricarico. In nessun modo G.Fluid sarà tenuta responsabile per danni diretti dovuti al ritardo nella consegna.

RISERVA DELLA PROPRIETÀ/PATTO DI RISERVATO DOMINIO

Tutti i ns. prodotti sono venduti con patto di riservato dominio. Pertanto sino a quando non saranno integralmente pagate le fatture, i prodotti si intendono di ns. proprietà, ai sensi dell'art. 1523 C.C.

RESPONSABILITÀ DEL TRASPORTO

Tutti i rischi del trasporto dei prodotti sono esclusivamente a carico del cliente anche quando la consegna è franco destino.

LUOGO DI GIURISDIZIONE

Il Foro di Modena è il Foro competente a definire ogni controversia relativa alla vendita di prodotti G. Fluid.

PREZZI SCONTATI

L'ufficio vendite, su richiesta del cliente, potrà applicare sconti per forniture giudicate elevate a discrezione della G.Fluid.

FILTRATION REQUIREMENTS ACCORDING ISO 4406					
FILTERFEINHEIT LAUT ISO 4406					
APPLICATION ANWENDUNG	ISO 4406	5 µm particles in 1 ml 5 µm Partikel in 1 ml		15 µm particles in 1 ml 15 µm Partikel in 1 ml	
		more than mehr als	up to bis zu	more than mehr als	up to bis zu
21-35 MPa high performance systems Proportional controls High cycle applications	16/13	320	640	40	80
21-35 MPa Hochleistungssysteme Proportionalkontrollen Schwierige Anwendungen					
Up to 21 MPa general mobile-industrial systems Spool valves Pilot orifice valves	18/14	1300	2500	80	160
Bis zu 21 MPa Allgemeine Industrie-Systeme Wegeschieber Vorgesteuerte Ventile					
Low pressure systems Low cycle Pilot lines	19/15	2500	5000	160	320
Niedrigdrucksysteme Einfache Anwendungen Vorgesteuerte Kreisläufe					

Recommended Viscosity - Empfohlene Viskosität: 10-400 cSt

Viscosity limits for hydraulic oil according to DIN 51519

Viskositätsgrenzen für Hydrauliköl lt. DIN 51519

ISO Viscosity Class ISO Viskositätsklasse	Average viscosity at 40 °C Mittlere Viskosität bei 40°C mm ² /s	Viscosity limits at 40 °C mm ² /s Viskositätsgrenzen bei 40°C	
		min.	max.
ISO VG 2	2.2	1.98	2.42
ISO VG 3	3.2	2.88	3.52
ISO VG 5	4.6	4.14	5.06
ISO VG 7	6.8	6.12	7.48
ISO VG 10	10	9	11
ISO VG 15	15	13.5	16.5
ISO VG 22	22	19.8	24.2
ISO VG 32	32	28.8	35.2
ISO VG 46	46	41.4	50.6
ISO VG 68	68	61.2	74.8
ISO VG 100	100	90	110
ISO VG 150	150	135	165
ISO VG 220	220	198	242
ISO VG 320	320	288	352
ISO VG 460	460	414	506
ISO VG 680	612	612	748
ISO VG 1000	1000	900	1100
ISO VG 1500	1500	1350	1650

Example of viscosity curves - Beispiel für eine Viskositätskurve

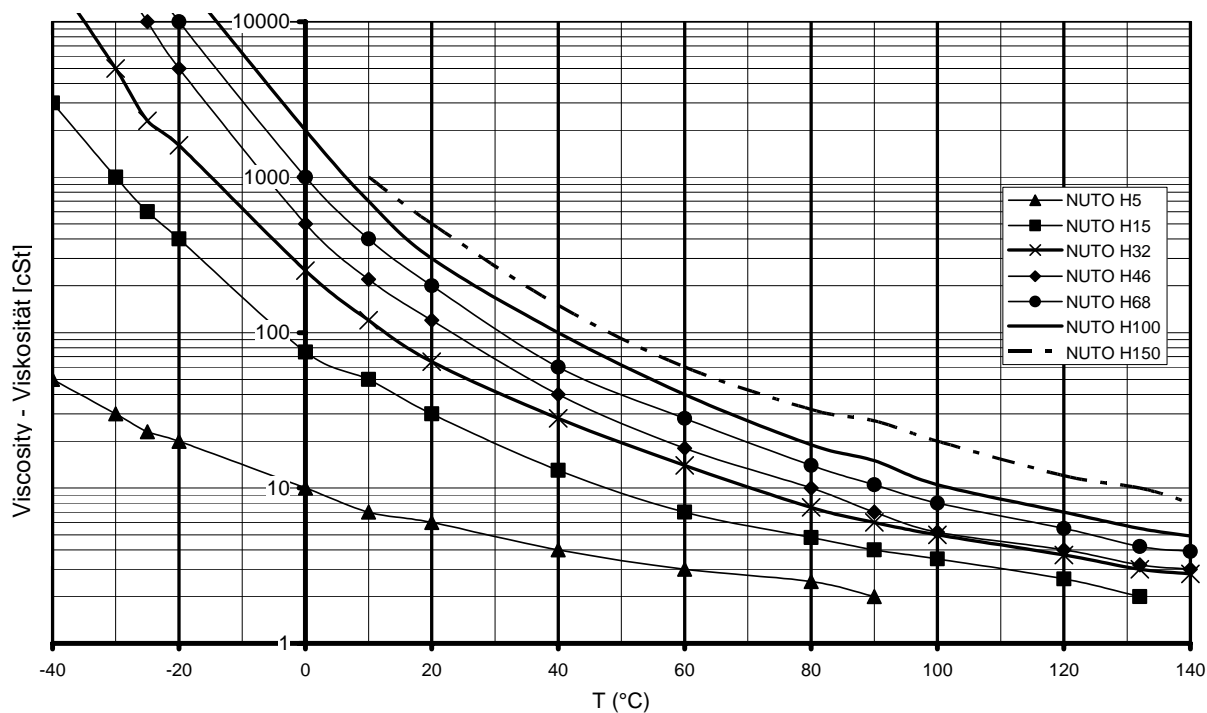

1. MATERIALS
**Standard components (spools,
poppets, seats, bodies, nuts, ...)**
1. MATERIALIEN
**Standardkomponenten (Schieber,
Verschlüsse, Ventilsitze und -körper,...)**

- 11SMnPb37 (EN10087)
- 36SMnPb14 (EN10087)
- 16CrNi4Pb (EN10025)
 - 2011 Al Cu6BiPb
- CW 614 N (EN 12164)
 - AISI 304
 - AISI 316

11SMnPb37 (EN10087)

	C	Mn	Si	P	S	Pb	HB	R	Rs	A5%
Min		1.000			0.340	0.200	112	460	375	8
Max	0.140	1.500	0.050	0.110	0.400	0.350	169	710		

36SMnPb14 (EN10087)

	C	Mn	Si	P	S	Pb	HB	R	Rs	A5%
Min	0.320	1.300	0.100		0.100	0.200	166	600	390	7
Max	0.390	1.700	0.400	0.060	0.180	0.350	222	840		

16CrNi4Pb (EN10025)

	C	Mn	Si	P	S	Cr	Ni	Pb	HB	R	Rs	A5%
Min	0.13	0.7			0.02	0.6	0.8			830	640	10
Max	0.19	1.0	0.4	0.035	0.04	1.0	1.1	0.35	225	1130		

2011 Al Cu6BiPb

	Si	Fe	Cu	Zn	Bi	Pb	Other	Al	R	Rs	A%
% mass	0.4	0.7	5.0-6.0	0.3	0.2-0.6	0.2-0.6	0.3	remaining	370	250	13

CW 614 N (EN 12164)

	Cu	S	Pb	Other	Fe	Ni	A%
Min	0.57		0.250				5
Max	0.59	0.300	0.350	0.2	0.3	0.3	

AISI 304

	C	Cr	Mn	Ni	Si	P	S	Other	R	Rs	A%
Min		17		8					500	195	35
Max	0.07	19.5	2.0	10.5	1.0	0.045	0.015	0.110	700		

AISI 316

	C	Cr	Mn	Ni	Si	P	S	MO	Other	R	Rs	A%
Min		16.5		10				2.0		510	205	40
Max	0.07	18.5	2.0	13	1.0	0.045	0.015	2.5	0.110	710		

See next page for details

Detaillierte Angaben: siehe nächste Seite

1.1.1. Heat treatments

- Carbonitring (up to 700 HV), to obtain fatigue resistance
- Quenching

1.1.2. Surface treatments

- White zincing
- Nickel plating
- Phosphation

1.1.3. NEW SURFACE TREATMENT:

- **ZINK-NICKEL-COATING:** High degree of corrosion resistance, particularly against exposure to high temperature, climatic conditions and salt (ASTM B117/JIS-Z2371: Resistance against salt spray is 720 – 800 hours). Passivation available in light silver or black.

1.1.4. Springs

- For standard springs Class C UNI3823 (C85)
- For high performance springs VDSiCr (EN10270-2001)

1.1.5. O-rings

- Acrylonitrile–Butadiene Rubber (NBR)
- Fluorocarbon Rubber (VITON)
- Hydrogenated Acrylonitrile–Butadiene Rubber (HNBR)

1.1.6. Back up rings

- Acrylonitrile–Butadiene Rubber (NBR)
- PTFE

1.1.7. Standard manifolds

- Natural Aluminium 2011 Al Cu6BiPb (anodisation upon request with different colours: silver, black, ...)
- White zinc coated steel 11SMnPb37 (EN 10087)
- ZINK-NICKEL-COATING 11SMnPb37 (EN 10087) (see chapter 1.1.3)

1.1.1. Hitzebehandlungen

- Karbonitrierung (bis zu 700 HV), um Belastungsfestigkeit zu erhalten
- Härtung

1.1.2. Oberflächenbehandlungen

- Weißverzinkung
- Vernickelung
- Phosphatierung

1.1.3. NEUE OBERFLÄCHENBEHANDLUNG

- **ZINK-NICKEL-BESCHICHTUNG:** Hohe Korrosionsbeständigkeit, insbesondere gegen Temperatur-, Klima- und Salzbelastung (ASTM B117/JIS-Z2371: Resistenz gegen Salznebel beträgt 720 bis 800 Stunden). Passivierung erhältlich in hell Silber oder schwarz.

1.1.4. Federn

- Standardfedern Klasse C UNI3823 (C85)
- Hochleistungs-Federn VDSiCr (EN10270-2001)

1.1.5. O-Ringe

- Acrylnitril-Butadien-Kautschuk (NBR)
- Hydrierter Acrylnitril-Butadien-Kautschuk (HNBR)
- Fluorkarbon-Kautschuk (VITON)

1.1.6. Stützringe

- Acrylnitril-Butadien-Kautschuk (NBR)
- PTFE

1.1.7. Standardgehäuse

- Unbehandeltes Aluminium 2011 AlCu6BiPb (Anodenoxydation auf Anfrage in verschiedenen Farben: Silber, Schwarz, ...)
- Weißverzinkter Stahl 11SMnPb37 (EN10087)
- ZINK-NICKEL-BESCHICHTUNG 11SMnPb37 (EN 10087) (siehe Kapitel 1.1.3)

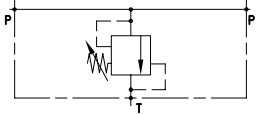
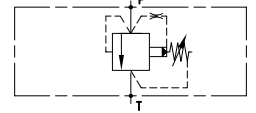
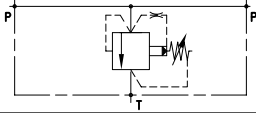
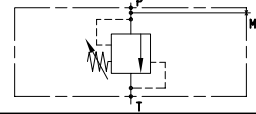
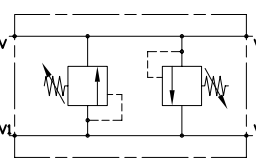
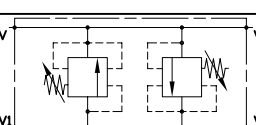
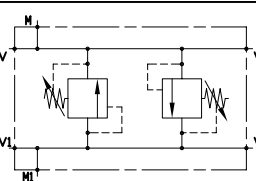
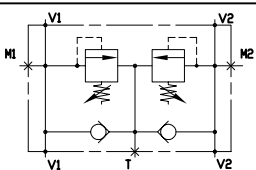
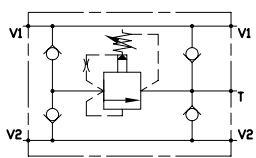
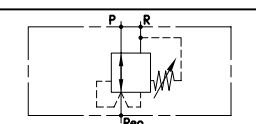
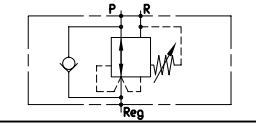
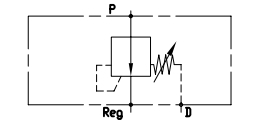
Scheme Schema	Description Bezeichnung	max flow max Durchfluß	max pressure max Arbeitsdruck	page Seite
	GVS-D-80-01	60 l/min 15.8 gpm	35 MPa 5076 psi	1.001.10
	GVS-D-150-01	150 l/min 39.6 gpm	35 MPa 5076 psi	1.001.15
	GVS-D-150-02	150 l/min 39.6 gpm	21 MPa 3045 psi	1.001.16
	GVS-SD-150 GVS-SD-250	150 l/min 39.6 gpm	35 MPa 5076 psi	1.001.51 1.001.52
	GVS-DI-16-10 GVS-DI-18-10 GVS-DI-31-10 GVS-DI-80-10	20 l/min - 5.3 gpm 20 l/min - 5.3 gpm 30 l/min - 7.9 gpm 80 l/min - 21.1 gpm	35 MPa 5076 psi	1.009.01 1.009.02 1.010.01 1.010.03
	GVS-DI-31-10	30 l/min 7.9 gpm	35 MPa 5076 psi	1.010.02
	GVS-DI-250-11	240 l/min 63.4 gpm	35 MPa 5076 psi	1.010.23
	GVS-DI-80-30 GVS-DI-150-31	60 l/min 15.8 gpm 150 l/min 39.6 gpm	35 MPa 5076 psi	1.011.05 1.011.10
	GVS-DI-150-70	150 l/min 39.6 gpm	35 MPa 5076 psi	1.012.01
	GRP-20-R	20 l/min 5.3 gpm	35 MPa 5076 psi	1.015.05
	GRP-20-R-VU	20 l/min 5.3 gpm	25 MPa 3556 psi	1.015.10
	GRP-150	120 l/min 31.7 gpm	35 MPa 5076 psi	1.015.15

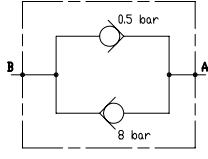
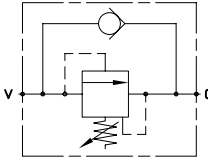
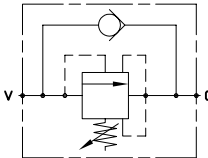
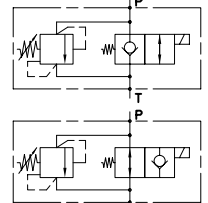
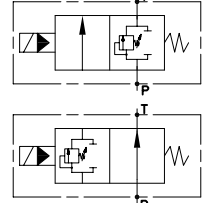
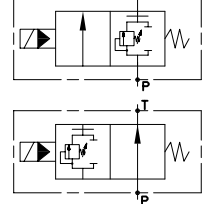
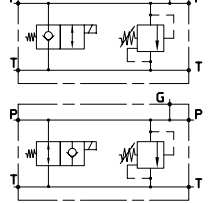
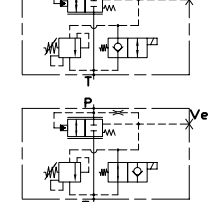
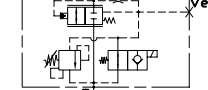
Scheme Schema	Description Bezeichnung	max flow max Durchfluß	max pressure max Arbeitsdruck	page Seite
	GUD	80 l/min 21.1 gpm	40 MPa 5689 psi	1.020.01
	GSQ-20-LM-38 GSQ-20-LM-12 GSQ-31-2 GSQ-24 GSQ-150-2-3	50 l/min - 13.2 gpm 80 l/min - 21.1 gpm 30 l/min - 7.9 gpm 80 l/min - 21.1 gpm 150 l/min - 39.6 gpm	35 MPa 5076 psi	1.020.11 1.020.12 1.021.02 1.021.50 1.022.01
	GSQ-31I-2 GSQ-24I GSQ-24I-82 GSQ-150I-2-3	30 l/min - 7.9 gpm 80 l/min - 21.1 gpm 80 l/min - 21.1 gpm 150 l/min - 39.6 gpm	35 MPa 5076 psi	1.021.03 1.021.52 1.021.55 1.022.02
	GVS-BP-PM208-SA-SC	30 l/min 7.9 gpm	35 MPa 5076 psi	1.040.02
	GVS-BP-GSVR-150-SA-SC-34	150 l/min 39.6 gpm	35 MPa 5076 psi	1.040.06
	GVS-BP-GSVRT-150-SB-34	150 l/min 39.6 gpm	35 MPa 5076 psi	1.040.07
	GVS-BP-VMG80-SA-SC	80 l/min 21.1 gpm	35 MPa 5076 psi	1.041.03
	GVS-BP-VCC-PM208-SA-SC	200 l/min 52.8 gpm	35 MPa 5076 psi	1.042.10
	GVS-BP-VCC-PM005-SA-SC			1.042.11

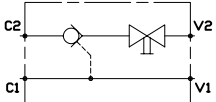
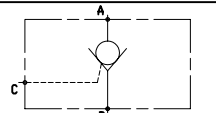
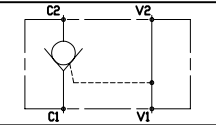
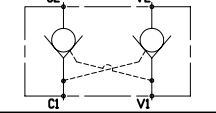
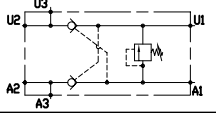
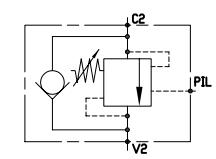
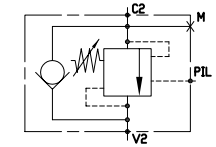
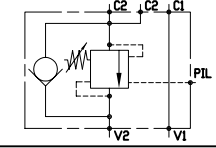
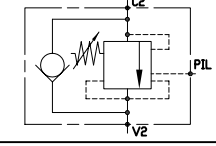
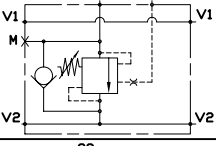
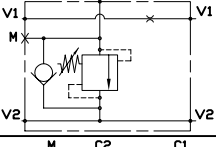
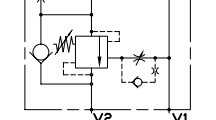
Schema Schema	Description Bezeichnung	max flow max Durchfluß	max pressure max Arbeitsdruck	page Seite
	GVU-SE-RLD GVU-SE-RLS	60 l/min 15.8 gpm	35 MPa 5076 psi	2.001.10 2.001.20
	GULP-_-_-	15-35-55 l/min 3.9-9.2-14.5 gpm	50-70 MPa 7250-10150 psi	2.002.10
	GVU-P-SE-14	20 l/min 15.3 gpm	35 MPa 5076 psi	2.002.50
	GVU-DE GVU-DE-F1	20-50-80 l/min 7.9-13.2-21.1 gpm	35 MPa 5076 psi	2.002.80 2.002.90
	GVU-DE-VS-38-FB	40 l/min 10.6 gpm	35 MPa 5076 psi	2.002.110
	VBG-SE-61 VBG-SE-62 VBG-SE-78 VBG-SE-30 VBG-SE-71	40 l/min - 10.6 gpm 40 l/min - 10.6 gpm 40 l/min - 10.6 gpm 60 l/min - 15.9 gpm 220 l/min - 58.0 gpm	35 MPa 5076 psi	2.003.10 2.003.20 2.003.30 2.003.70 2.003.200
	VBG-SE-63 VBG-SE-64	70 l/min 18.5 gpm	35 MPa 5076 psi	2.003.40 2.003.40
	VBG-SE-30-09	60 l/min 15.9 gpm	35 MPa 5076 psi	2.003.50
	VBG-SE-30I	60 l/min 15.9 gpm	35 MPa 5076 psi	2.003.80
	VBG-SE-F1-30-PLR	60 l/min 15.9 gpm	35 MPa 5076 psi	2.003.90
	VBG-SE-F1-30-38-PLR	60 l/min 15.9 gpm	35 MPa 5076 psi	2.003.100
	VBG-SE-30-PLR VBG-SE-33-PLR VBG-SE-F1-33-PLR	60 l/min - 15.9 gpm 150 l/min - 39.6 gpm 150 l/min - 39.6 gpm	35 MPa 5076 psi	2.003.110 2.003.120 2.003.140

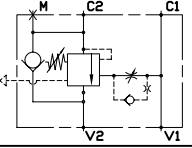
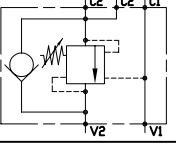
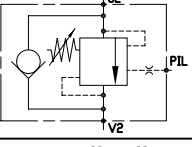
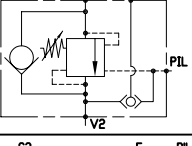
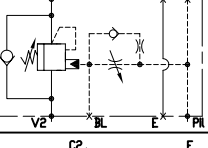
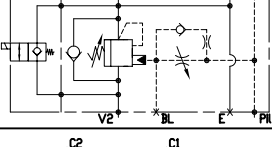
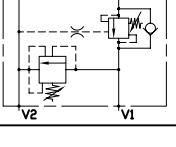
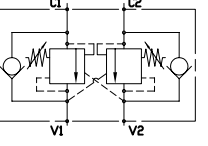
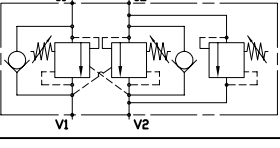
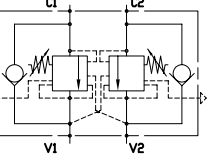
Scheme Schema	Description Bezeichnung	max flow max Durchfluß	max pressure max Arbeitsdruck	page Seite
	VBG-SE-33-I-PLR VBG-SE-F1-33-I-PLR VBG-SE-F1-33-43-I-PLR	35 MPa 5076 psi	35 MPa 5076 psi	2.003.130 2.003.150 2.003.160
	VBG-SE-24	140 l/min 36.9 gpm	35 MPa 5076 psi	2.003.170
	VBG-SE-150 VBG-SE-150-39	150 l/min 39.6 gpm	35 MPa 5076 psi	2.003.180 2.003.190
	VBG-SE-72	220 l/min 58.0 gpm	35 MPa 5076 psi	2.003.210
	VBG-SE-100	100 l/min 26.4 gpm	35 MPa 5076 psi	2.003.500
	VBG-SE-100-BP	100 l/min 26.4 gpm	35 MPa 5076 psi	2.003.510
	GVS-VMG31I-PB010-38-020-THM	40 l/min 10.6 gpm	20 MPa 2844 psi	2.003.700
	VBG-DE-78 VBG-DE-30 VBG-DE-F-30 VBG-DE-81 VBG-DE-24 VBG-DE-91 VBG-DE-92	40 l/min - 10.6 gpm 60 l/min - 15.9 gpm 60 l/min - 15.9 gpm 70 l/min - 18.5 gpm 140 l/min - 36.9 gpm 220 l/min - 58.0 gpm 220 l/min - 58.0 gpm	35 MPa 5076 psi	2.004.30 2.004.80 2.004.90 2.004.120 2.004.180 2.004.190 2.004.200
	VBG-DE-VM-30	60 l/min 15.9 gpm	35 MPa 5076 psi	2.004.100
	VBG-DE-30-I VBG-DE-F-30-I	60 l/min 15.9 gpm	35 MPa 5076 psi	2.004.130 2.004.140

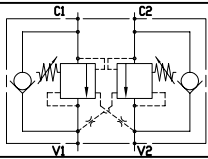
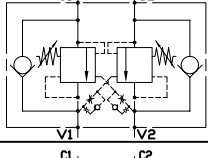
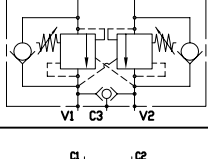
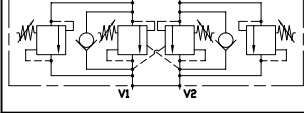
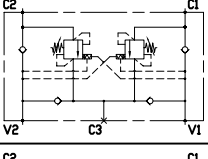
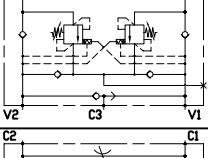
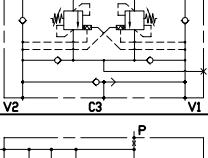
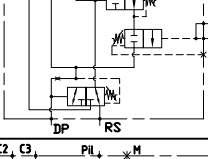
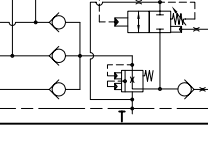
Scheme Schema	Description Bezeichnung	max flow max Durchfluß	max pressure max Arbeitsdruck	page Seite
	VBG-DE-33	150 l/min 39.6 gpm	35 MPa 5076 psi	2.004.150
	VBG-DE-33-PLR VBG-DE-F1-33-PLR	150 l/min 39.6 gpm	35 MPa 5076 psi	2.004.160 2.004.170
	VBG-DE-SL-30	60 l/min 15.9 gpm	35 MPa 5076 psi	2.004.300
	VBG-DE-2VM-25	25 l/min 6.6 gpm	35 MPa 5076 psi	2.004.400
	GVA-50-52	40 l/min 10.6 gpm	35 MPa 5076 psi	2.010.10
	GVA-120-53-S GVA-250-53-	120 l/min - 31.7 gpm 200 l/min - 53.0 gpm	35 MPa 5076 psi	2.010.17 2.010.27
	GVA-120-53-ST-S GVA-120-53-ST-10-S	120 l/min 31.7 gpm	35 MPa 5076 psi	2.010.20 2.010.21
	GLM-3PS-20-12-S	20 l/min 5.3 gpm	35 MPa 5076 psi	2.050.10
	GLM-60-12-S	60 l/min 15.9 gpm	35 MPa 5076 psi	2.050.03

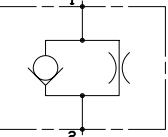
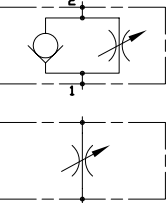
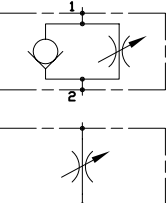
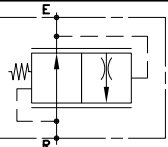
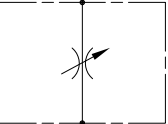
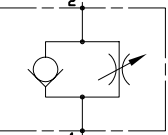
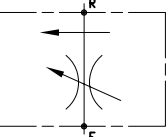
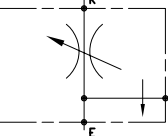
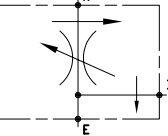
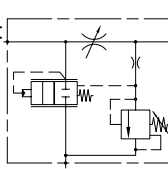
Scheme Schema	Description Bezeichnung	max flow max Durchfluß	max pressure max Arbeitsdruck	page Seite
	GVU-18-MF14	12 l/min 3.2 gpm	35 MPa 5076 psi	3.001.01
	GLR-___ GLS-___	100 l/min 26.4 gpm	35 MPa 5076 psi	3.001.02
	FR116 FR138 FR016 FR038	30 l/min 7.9 gpm	35 MPa 5076 psi	3.001.03
	FRC14	10 l/min 2.6 gpm	25 MPa 3626 psi	3.001.04
	GTS-___	15-30-50 l/min 3.9-7.9-13.2 gpm	40 MPa 5081 psi	3.001.05
	GTC-___	10-18-33 l/min 2.6-4.8-8.7 gpm	25 MPa 3626 psi	3.001.11
	GRF2-10 GRF2-12	20-30 l/min 5.3-3.9 gpm 55-90 l/min 14.5-23.8 gpm	35 MPa 5076 psi	3.009.01 3.009.02
	GRF3-10 GRF3-12	20-30 l/min 5.3-3.9 gpm 90-150 l/min 23.8-39.6 gpm	35 MPa 5076 psi	3.010.01 3.010.02
	GRF3C-12	90-150 l/min 23.8-39.6 gpm	35 MPa 5076 psi	3.011.02
	GRF3-VM-34	150 l/min 39.6 gpm	21 MPa 2987 psi	3.015.02

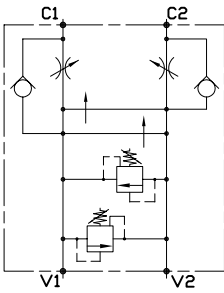
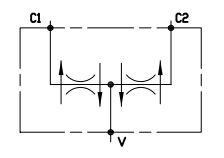
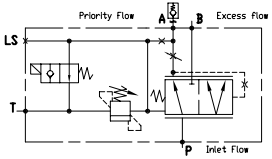
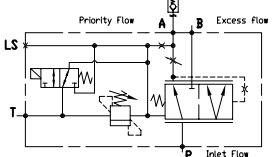
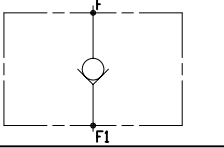
Scheme Schema	Description Bezeichnung	max flow max Durchfluß	max pressure max Arbeitsdruck	page Seite
	GRF3-DE-VU-34-___	150 l/min 39.6 gpm	35 MPa 5076 psi	3.016.02
	GDF 38-12 GDF 34-100 GDF16_ - GDF16F	6-11-22 l/min 1.6-2.9-5.8 gpm 150 l/min 39.6 gpm 4-8-16-32-50 l/min 1.6-2.9-5.8 gpm 6-11-22 l/min 1.1-2.2-4.2-8.4- 13.2 gpm	35 MPa 5076 psi	3.020.01 3.020.02 3.020.03 3.020.04
	GRF-SA-PM-12 GRF-SA-PM-34	85 l/min 22.4 gpm 140 l/min 36.9 Gpm	35 MPa 5076 psi	3.090.01 3.091.01
	GRF-SA-PM-100 GRF-SA-PM-144	220 l/min 58 gpm 300 l/min 79.2 gpm	35 MPa 5076 psi	3.092.01 3.092.01
	GVU-MF GFPR	300 l/min 79.2 gpm	35 MPa 5076 psi	3.099.01 3.099.05

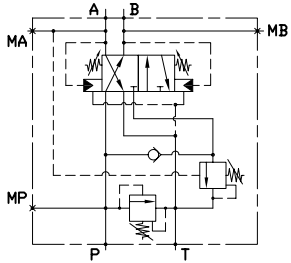
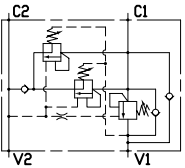
Scheme Schema	Description Bezeichnung	max flow max Durchfluß	max pressure max Arbeitsdruck	page Seite
	<p><i>GVS-RIG-AUT-100-031-02</i></p> <p><i>GVS-RIG-AUT-200-032-01</i></p>	<p>100 l/min 26.4 gpm</p> <p>200 l/min 52.8 gpm</p>	<p>35 MPa 5076 psi</p>	<p>4.001.20</p> <p>4.001.24</p>
	<p><i>GVS-RIG-3PB042-048-RUD</i></p>	<p>400 l/min 105.6 gpm</p>	<p>35 MPa 5076 psi</p>	<p>4.001.30</p>

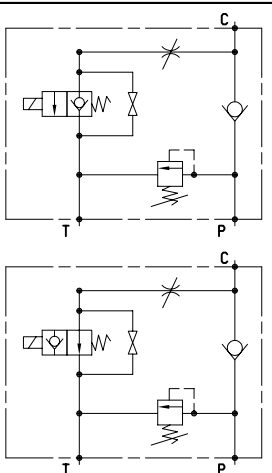
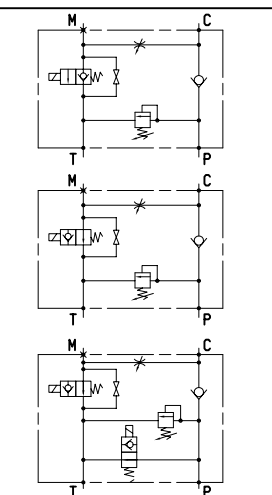
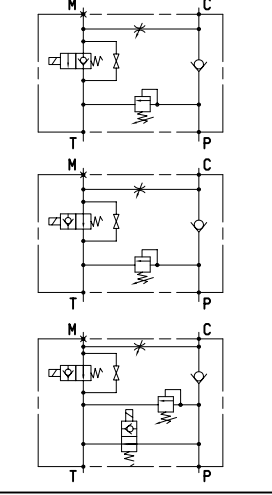
Scheme Schema	Description Bezeichnung	max flow max Durchfluß	max pressure max Arbeitsdruck	page Seite
	<p>GV-CE-SE-10-ST-1</p> <p>GV-CE-SE-10-ST-2</p>	<p>30 l/min 7.9 gpm</p>	<p>25 MPa 3626 psi</p>	<p>5.001.01</p>
	<p>GVS-VMG31-SCE08-VU</p> <p>GVS-VMG31-SAE08-VU</p> <p>GVS-VMG31-SCE08-BYP-VU</p>	<p>30 l/min 7.9 gpm</p>	<p>25 MPa 3626 psi</p>	<p>5.001.02</p>
	<p>GVS-GVSP150-SCE34-VU</p> <p>GVS-GVSP150-SAE34-VU</p> <p>GVS-GVSP150-SCE34-BYP-VU</p>	<p>80 l/min 21.1 gpm</p>	<p>25 MPa 3626 psi</p>	<p>5.001.03</p>

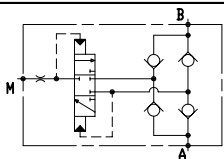
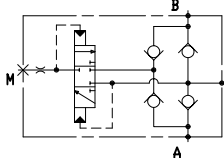
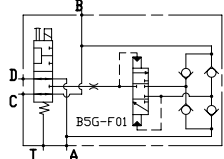
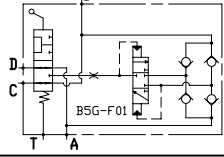
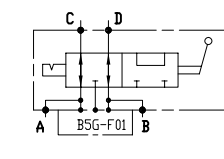
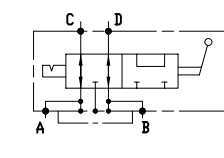
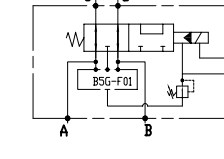
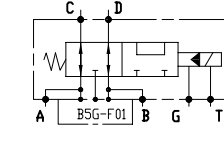
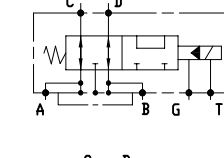
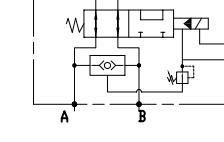
Scheme Schema	Description Bezeichnung	max flow max Durchfluß	max pressure max Arbeitsdruck	page Seite
 	<p>B5G</p> <p>B5G-F01</p>	<p>60 l/min 15.8 gpm</p>	<p>42 MPa 5937 psi</p>	<p>6.001.01</p>
 	<p>GSV19-B5G-F-12</p> <p>GSV19-B5G-F-L-12</p>	<p>80 l/min 21.1 gpm</p>	<p>31 MPa 4409 psi</p>	<p>6.002.01</p>
     	<p>GSV25-NP-L-B5G-F-100</p> <p>GSV25-NP-L-100</p> <p>GSV25-NP-E-B5G-F-100</p> <p>GSV25-NP-D-B5G-F-100</p> <p>GSV25-NP-D-100</p> <p>GSV25-NP-E-100</p>	<p>300 l/min 79.2 gpm</p>	<p>42 MPa 5973 psi</p>	<p>6.003.01</p>

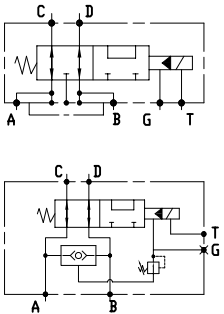
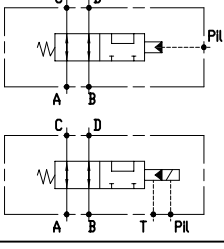
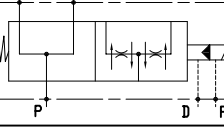
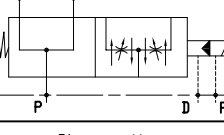
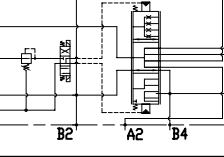
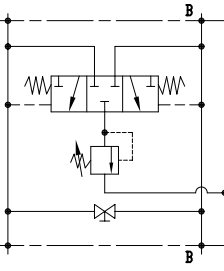
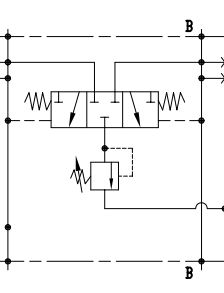
Scheme Schema	Description Bezeichnung	max flow max Durchfluß	max pressure max Arbeitsdruck	page Seite
	GSV25-NP-D-B5G-F-100-___-ATEX GSV25-NP-D-F-100-___-ATEX	300 l/min 79.2 gpm	42 MPa 5973 psi	6.003.02
	GSV30-I-114 GSV30-D-114-___	400 l/min 105.6 gpm	42 MPa 5973 psi	6.004.01
	GVS-BD-107-12 GVS-BD-105-34	100 l/min 26.4 gpm 120 l/min 31.7 gpm	50 MPa 7112 psi 52 MPa 7396 psi	6.009.01 6.010.01
	GVS-BD30-07-DF-_-SAE100-34-_VDC GVS-BD-101-1	300 l/min 79.2 gpm 300 l/min 79.2 gpm	45 MPa 6400 psi 42 MPa 5973 psi	6.011.01 6.011.51
	GVS-SPBD-202-12 GVS-SPBD-203-12	80 l/min 21.1 gpm	35 MPa 5076 psi	6.020.01 6.020.02
	GVS-HTP-01	100 l/min 26.4 gpm	35 MPa 5076 psi	6.050.10
	GVS-HTP-F02	100 l/min 26.4 gpm	35 MPa 5076 psi	6.050.20

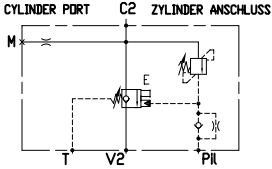
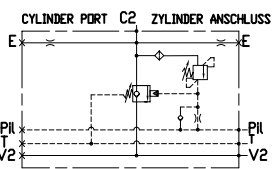
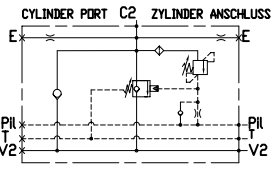
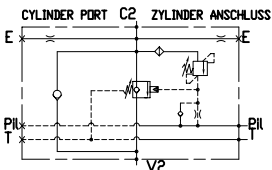
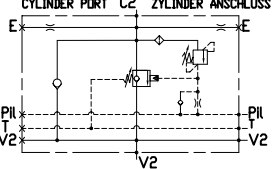
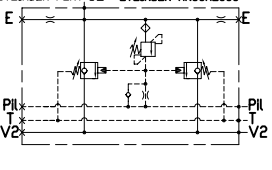

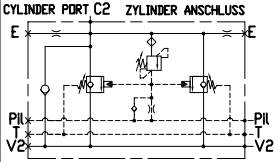
Scheme Schema	Description Bezeichnung	max flow max Durchfluß	max pressure max Arbeitsdruck	page Seite
	VMT-10-DX-__-1	40 l/min-10.5 gpm	42 MPa 5937 psi	7.005.01
	VMT-10-SX-__-1	40 l/min-10.5 gpm		7.006.01
	VMT-14-DX-__-1	100 l/min-26.4 gpm		7.010.01
	VMT-14-SX-__-1	100 l/min-26.4 gpm		7.011.01
	VMT-33-DX-__-1	150 l/min-39.6 gpm		7.015.01
	VMT-33-SX-__-1	150 l/min-39.6 gpm		7.016.01
	VMT-33-F12-1	150 l/min 39.6 gpm	42 MPa 5937 psi	7.025.01
	VMT-33-F34-__-1	250 l/min-66 gpm	42 MPa 5937 psi	7.026.01
	VMT-33-F34-027-1	250 l/min-66 gpm		7.027.01
	VMT-42-F-__-1	400 l/min-106 gpm		7.030.01
	VMT-42-F114-1	500 l/min-132 gpm		7.040.01
	VMT-42-F114-043-1	500 l/min-132 gpm		7.043.01
	VMT-33-F34-028-1	250 l/min-66 gpm	42 MPa 5937 psi	7.028.01
	VMT-42-F1-033-1	400 l/min-106 gpm		7.033.01
	VMT-42-F1-034-1	400 l/min-106 gpm		7.034.01
	VMT-42-3F1-1	400 l/min 106 gpm	42 MPa 5937 psi	7.035.01
	VMT-242-F1-1	500 l/min 132 gpm	42 MPa 5937 psi	7.050.01
	VMT-242-F114-1			7.055.01

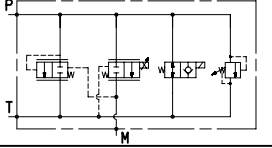
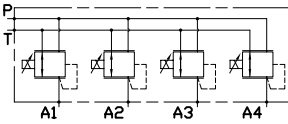
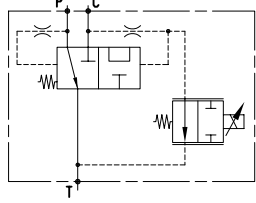
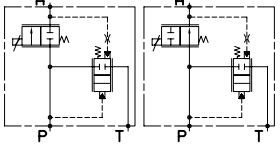
Scheme Schema	Description Bezeichnung	max flow max Durchfluß	max pressure max Arbeitsdruck	page Seite
	VMT-242-F112-1	700 l/min 172 gpm	55 MPa 7936 psi	7.060.01

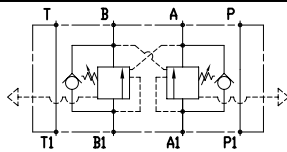
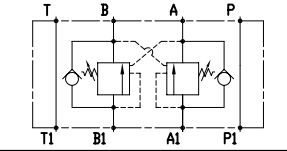
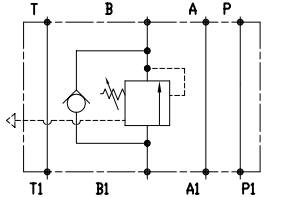
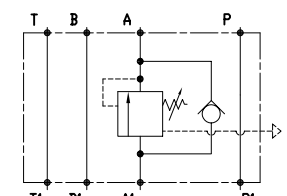
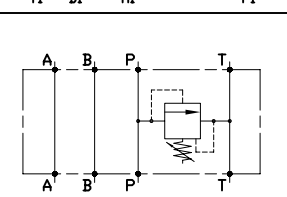
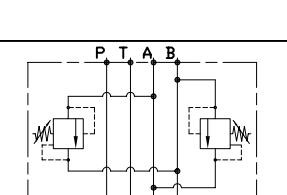
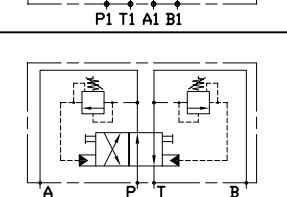
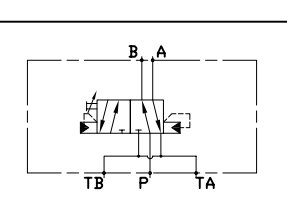
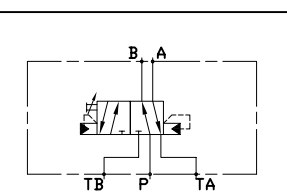
Scheme Schema	Description Bezeichnung	max flow max Durchfluß	max pressure max Arbeitsdruck	page Seite
	<i>GVP-RF-CP-VE-VS-12-CLS</i>	30 l/min 7.9 gpm	25 MPa 3626 psi	8.001.01
	<i>GVS-4VEP-18-027-ERK</i>	2 l/min 0.53 gpm	25 MPa 3626 psi	8.005.01
	<i>GEI-VE-C021-RPP-SCI-38-SE</i>	30 l/min 7.9 gpm	21 MPa 2987 psi	8.005.11
	<i>GVP-N_LCC-STR</i>	20 l/min 5.3 gpm	25 MPa 3626 psi	8.010.01

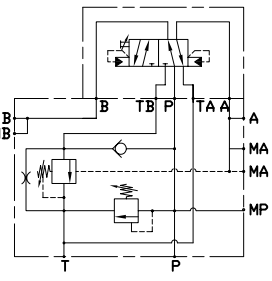
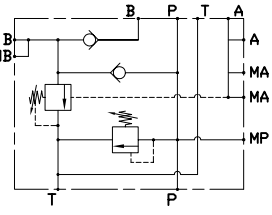
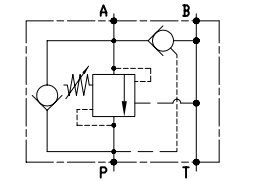
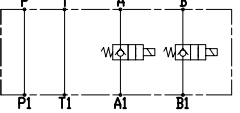
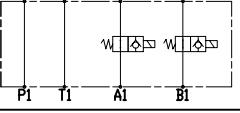
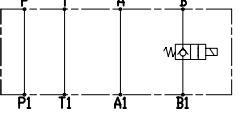
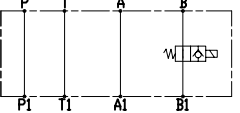
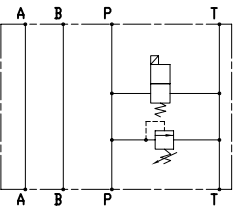
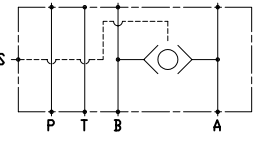
Scheme Schema	Description Bezeichnung	max flow max Durchfluß	max pressure max Arbeitsdruck	page Seite
	GEM-B-06-DE-122	60 l/min 15.9 gpm	25 MPa 3626 psi	9.001.01
	GEM-B-10-DE-123	80 l/min 21.1 gpm	25 MPa 3626 psi	9.001.02
	GEM-06-SE-B	60 l/min 15.9 gpm	25 MPa 3626 psi	9.001.11
	GEM-06-SE-A			
	GEM-06-VMG31-004-RJK GEM-ES06-VMG80 GEM-10-VMG80-005-RJK	30 l/min-7.9 gpm 80 l/min-21.1 gpm 80 l/min-21.1 gpm	25 MPa-3626 psi 35 MPa-5076 psi 25 MPa-3626 psi	9.002.01 9.002.03 9.002.05
	GEM-ES-06-PM022	40 l/min 10.6 gpm	35 MPa 5076 psi	9.003.02
	GEM-06-ADV-25 GEM-10-ADV-26	40 l/min-10.6 gpm 90 l/min-23.8 gpm	30 MPa 4350 psi	9.003.52 9.003.56
	GEM-10-ADV-27	80 l/min 21.1 gpm	30 MPa 4350 psi	9.003.60
	GEM-10-ADV-31	80 l/min 21.1 gpm	30 MPa 4350 psi	9.003.64

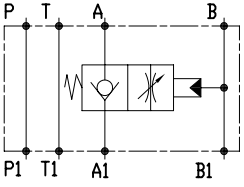
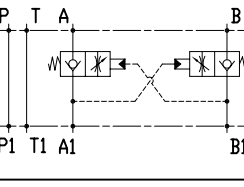
Scheme Schema	Description Bezeichnung	max flow max Durchfluß	max pressure max Arbeitsdruck	page Seite
	GEM-10-ADV-RIG-28	100 l/min 26.4 gpm	35 MPa 5076 psi	9.003.70
	GEM-10-RIG-29	100 l/min 26.4 gpm	35 MPa 5076 psi	9.003.80
	GEM-06-PB-RIG	30 l/min 7.9 gpm	35 MPa 5076 psi	9.010.01
	GEM-06-E-0508S	40 l/min 10.6 gpm	35 MPa 5076 psi	9.013.01
	GEM-06-E-0608S			
	GEM-06-E-0908S	40 l/min 10.6 gpm	35 MPa 5076 psi	9.015.01
	GEM-06-E-1008S			
	GEM-06P-N-R	40 l/min 10.6 gpm	35 MPa 5076 psi	9.020.01
	GEM-ES-45-S	80 l/min 21.1 gpm	35 MPa 5076 psi	9.050.01

Scheme Schema	Description Bezeichnung	max flow max Durchfluß	max pressure max Arbeitsdruck	page Seite
	GEM-VUST-06-CSEIA	40 l/min 10.6 gpm	25 MPa 3626 psi	9.090.10
	GEM-VUST-06-CSEIB			
	GEM-VUST-06-DE	40 l/min 10.6 gpm	25 MPa 3626 psi	9.091.10

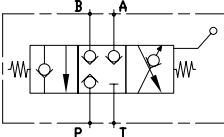
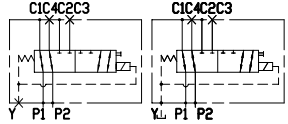
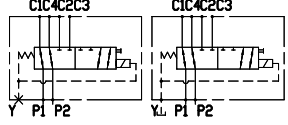
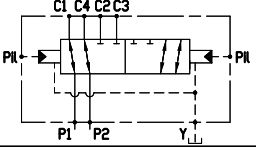
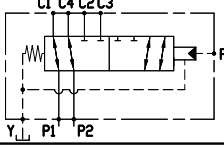
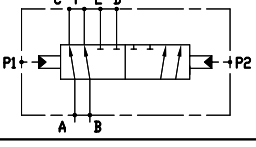
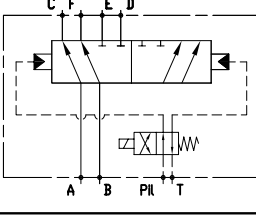
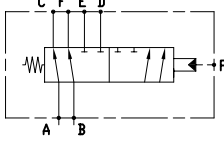
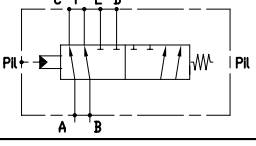
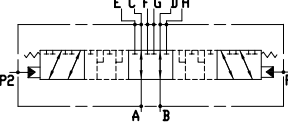
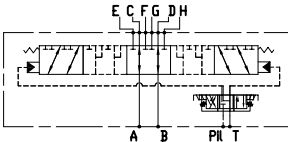
Scheme Schema	Description Bezeichnung	max flow max Durchfluß	max pressure max Arbeitsdruck	page Seite
	GVS-DSL43-023-BRN	30 l/min-7.9 gpm	50 MPa-7111 psi	10.001.01
	GVS-DSL43-090-BRN	120 l/min-31.7 gpm	30 MPa-4266 psi	10.001.02
	GED-ED3-80-34	80 l/min 21.1 gpm	35 MPa 5076 psi	10.001.51
	GED-ED6-80-34	80 l/min 21.1 gpm	35 MPa 5076 psi	10.002.10
	GED-ED6-80-34-PIDE	80 l/min 21.1 gpm	35 MPa 5076 psi	10.002.20
	GED-ED6-80-34-PIRM	80 l/min 21.1 gpm	35 MPa 5076 psi	10.002.30
	GED-ED6-300-1-PIDE	300 l/min 79.2 gpm	42 MPa 5974 psi	10.002.100
	GED-ED6-300-1	300 l/min 79.2 gpm	42 MPa 5974 psi	10.002.120
	GED-ED6-300-1-PIRM	300 l/min 79.2 gpm	42 MPa 5974 psi	10.002.130
	GED-ED6-300-1-PIRM-S	300 l/min 79.2 gpm	42 MPa 5974 psi	10.002.130
	GED-ED8-250-1	250 l/min 66 gpm	35 MPa 5076 psi	10.002.210
	GED-ED8-250-1-__	250 l/min 66 gpm	35 MPa 5076 psi	10.002.220

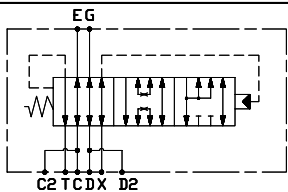
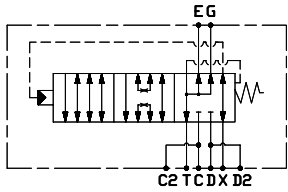
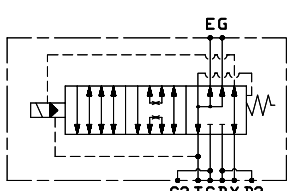
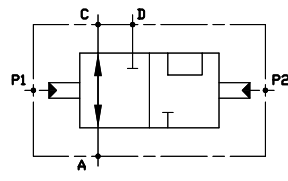
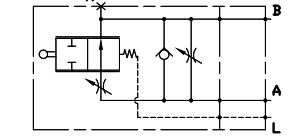
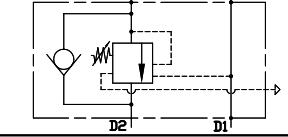
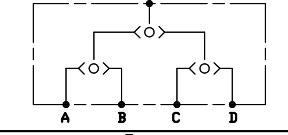
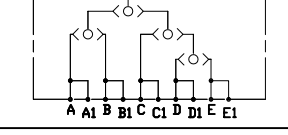
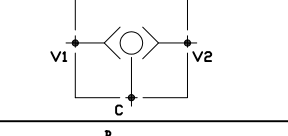
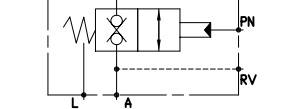
Scheme Schema	Description Bezeichnung	max flow max Durchfluß	max pressure max Arbeitsdruck	page Seite
	GED-ED5-FW-300-34-7640 GED-ED5-FW-300-114-7640			10.002.310 10.002.320
	GED-ED5-FW-300-34-7550 GED-ED5-FW-300-114-7550	300 l/min 79.2 gpm	42 MPa 5974 psi	10.002.310 10.002.320
	GED-ED5-FW-300-34-155 GED-ED5-FW-300-114-155			10.002.310 10.002.320
	GED-D3-300-1	300 l/min 79.2 gpm	42 MPa 5974 psi	10.002.410
	GVS-TRT-G911-059-ANT	250 l/min 66 gpm	31 MPa 4400 psi	10.003.01
	GVZ-PB020-007-CR	60 l/min 18.5 gpm	35 MPa 5076 psi	10.010.01
	GV-3SEL-04-14-HC	5 l/min 1.3 gpm	25 MPa 3626 psi	10.020.01
	GV-4SEL-04-11P-14-HC	5 l/min 1.3 gpm	25 MPa 3626 psi	10.020.02
	GV-SEL-14	50 l/min 13.2 gpm	35 MPa 5076 psi	10.020.11
	GVS-SB010-PIRM-042-NEU	10 l/min 2.6 gpm	42 MPa 5974 psi	10.030.11

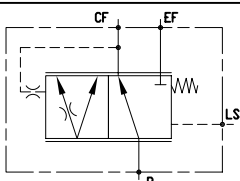
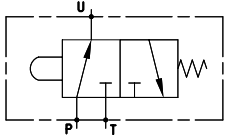
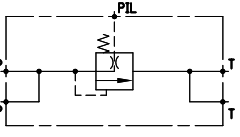
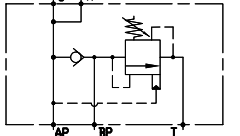
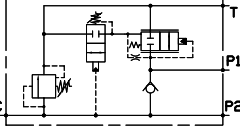
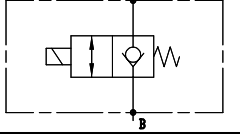
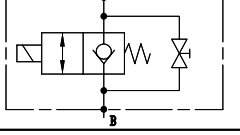
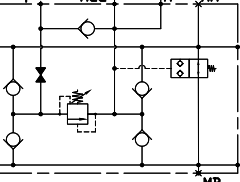
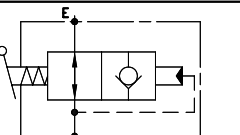
Scheme Schema	Description Bezeichnung	max flow max Durchfluß	max pressure max Arbeitsdruck	page Seite
	GRF-VPS-12	40 l/min 10.6 gpm	35 MPa 5076 psi	10.031.11
	GRF-VPS-12F			10.031.21
	GVD-3V-SCS-18	3 l/min 0.79 gpm	35 MPa 5076 psi	10.035.11
	GVR-CP-C115G-12-18-TMA	40 l/min 10.6 gpm	25 MPa 3626 psi	10.035.12
	GVS-EPD-038-PSC	70 l/min 18.5 gpm	35 MPa 5076 psi	10.040.10
	GVEP-2P-34	30 l/min 7.9 gpm	35 MPa 5076 psi	10.080.10
	GVE-SC-BF-38	30 l/min 7.9 gpm	25 MPa 3626 psi	10.090.03
	GVE-SC-BF-EM-38	30 l/min 7.9 gpm	25 MPa 3626 psi	10.090.23
	GVE-SC-BF-EM-12			10.090.26
	GVS-STA-38-005-04-KR	40 l/min 10.6 gpm	35 MPa 5076 psi	10.100.05
	VCP-F-06-12	30 l/min 7.9 gpm	25 MPa 3626 psi	10.100.10

Code/Artikelnr.	Page/Seite
004.01.09.00	9.002.01
005.01.09.00	9.002.05
005.02.11.04	10.100.05
007.02.07.03	10.010.01
017.05.07.10	10.090.23
018.05.07.10	10.090.03
019.05.07.10	10.090.26
020.03.09.00	2.003.700
023.03.09.00	10.001.01
024.04.04.00	2.002.110
027.10.10.-0	8.005.01
030.07.12.00	10.031.21
031.07.12.02	4.001.20
032.07.12.01	4.001.24
038.09.12.00	10.040.10
041.09.03.02	10.020.02
042.09.07.00	10.030.11
044.01.00.01	10.031.11
048.09.06.00	4.001.30
055.05.02.00	8.005.11
059.05.09.00	10.003.01
064.11.04.-0	8.001.01
070.05.00.00	10.035.12
090.11.09.00	10.001.02
1111010--00	3.099.01
111102-81200	3.001.01
113101----0	3.099.05
1131020----	1.020.01
1132101-1--00	2.002.10
114110-1--10	2.002.50
114111----10	2.001.10
114112----10	2.001.20
114201----0	2.002.80
1145059410-0	10.020.11
115201----0	2.002.90
12301---200	1.020.11
12302---200	1.020.12
1240113---0	1.001.10
1240114---0	1.001.15
1240214---0	1.001.16
1240324---0	1.001.51
1240325---0	1.001.52
14410806----	2.003.30
14410910----	2.003.60
14411010----	2.003.70
14411020----	2.003.80
14411110----	2.003.110
14411906----	2.004.30
1441--20----	2.004.130
14412010----	2.004.80
14412210----	2.004.300
14412310----	2.004.100
1441343-----	2.003.130

Code/Artikelnr.	Page/Seite
1441353----	2.003.120
1441363----	2.003.140
14413710---	2.003.90
144138-----	2.003.100
14413961----	2.003.190
144140-----	2.003.170
144141-----	2.003.180
14414244---	2.003.150
14414344---	2.003.160
14414434---	2.004.150
14414534---	2.004.160
14414634---	2.004.170
144150-----	2.004.180
144152-----	2.004.400
14415510---0	2.003.510
14415610---0	2.003.500
144161-----00	2.003.10
144162-----00	2.003.20
144163-----00	2.003.40
144164-----00	2.003.50
144171-----00	2.003.200
144172-----00	2.003.210
144181-----00	2.004.120
144191-----00	2.004.190
144192-----00	2.004.200
14512010---	2.004.90
14512020---	2.004.140
14512110---	2.004.110
15321--0000	3.001.02
153215--0000	3.001.06
153216--0000	3.001.05
153221--0000	3.001.11
15412101---	3.009.01
154121011--	3.009.02
154121030F-1	3.020.04
154122022--	3.010.01
154122022--	3.010.02
15412204---	3.011.02
15412206004-	3.091.01
15412206005-	3.092.01
15412206006-	3.092.02
15412206046-	3.091.01
15412206048-	3.092.01
15412206049-	3.092.02
15412210--0	3.015.02
154122160--	3.090.01
154132001--	3.016.02
154221010--	3.020.01
154221010--	3.020.02
154221030-1	3.020.03
1643331--0-0	10.001.51
1643361--0-0	10.002.10
1643561100-0	10.002.20

Code/Artikelnr.	Page/Seite
1643761100-0	10.002.30
1646--0-040	10.002.310
1646--0-060	10.002.320
16461610-0-0	10.002.120
16461880-0-0	10.002.220
1646561000-0	10.002.110
164663700050	10.002.410
164676-000-0	10.002.130
1647588000-0	10.002.210
1800432210-0	9.091.10
18104-2210-0	9.090.10
203050---0000	1.015.05
203100---0000	1.015.10
20315----0000	1.015.15
20505100---00	1.009.01
20521100---00	1.010.01
20523100---00	1.010.02
20529100---00	1.010.03
20529300---00	1.011.25
20531700---00	1.012.01
20535310---01	1.011.10
20535521-02--0	2.010.10
20535532-04--0	2.010.17
20535532-04--1	2.010.20
20535542-04--	2.010.21
20536110----00	1.010.23
20536533-05--0	2.010.27
20538100----01	1.009.02
206151---01	1.022.01
206152---00	1.022.02
206301---00	1.021.02
206302---00	1.021.03
206811---00	1.021.50
2068120---00	1.021.52
2068220---00	1.021.55
2071-----00	1.040.02
2073-03--00	1.041.03
2075-03--000	1.040.06
2075-03--000	1.040.07
2086----00	1.042.10
2086----50	1.042.11
21001-000000	6.001.01
210021--01-0	6.002.01
2100220--3-0	6.003.01
21002203-3-1	6.003.02
2100230--4--	6.004.01
2100311071--	6.009.01
2100321052--	6.010.01
2100331013--	6.011.51
2100412021-0	6.020.01
210041203100	6.020.02
21031010-1-0	6.050.10
2103102001-0	6.050.20

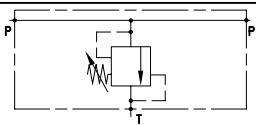
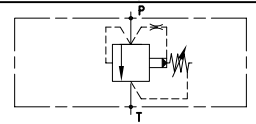
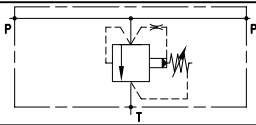
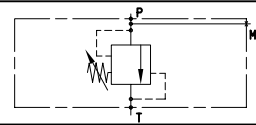
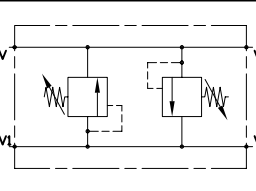
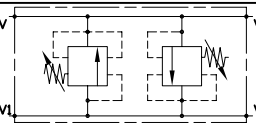
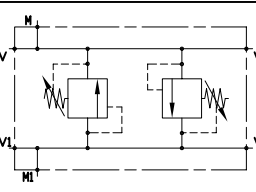
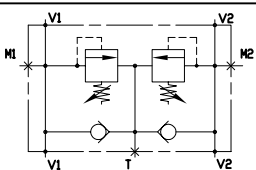
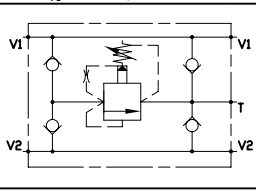
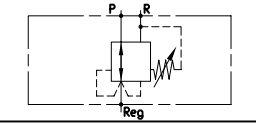
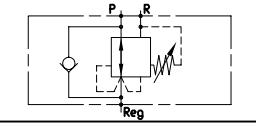
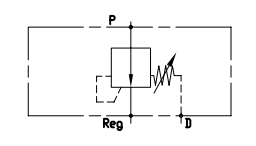
Schema Schema	Description Bezeichnung	max flow max Durchfluß	max pressure max Arbeitsdruck	page Seite
	GVS-D-80-01	60 l/min 15.8 gpm	35 MPa 5076 psi	1.001.10
	GVS-D-150-01	150 l/min 39.6 gpm	35 MPa 5076 psi	1.001.15
	GVS-D-150-02	150 l/min 39.6 gpm	21 MPa 3045 psi	1.001.16
	GVS-SD-150 GVS-SD-250	150 l/min 39.6 gpm	35 MPa 5076 psi	1.001.51 1.001.52
	GVS-DI-16-10 GVS-DI-18-10 GVS-DI-31-10 GVS-DI-80-10	20 l/min - 5.3 gpm 20 l/min - 5.3 gpm 30 l/min - 7.9 gpm 80 l/min - 21.1 gpm	35 MPa 5076 psi	1.009.01 1.009.02 1.010.01 1.010.03
	GVS-DI-31-10	30 l/min 7.9 gpm	35 MPa 5076 psi	1.010.02
	GVS-DI-250-11	240 l/min 63.4 gpm	35 MPa 5076 psi	1.010.23
	GVS-DI-80-30 GVS-DI-150-31	60 l/min 15.8 gpm 150 l/min 39.6 gpm	35 MPa 5076 psi	1.011.05 1.011.10
	GVS-DI-150-70	150 l/min 39.6 gpm	35 MPa 5076 psi	1.012.01
	GRP-20-R	20 l/min 5.3 gpm	35 MPa 5076 psi	1.015.05
	GRP-20-R-VU	20 l/min 5.3 gpm	25 MPa 3556 psi	1.015.10
	GRP-150	120 l/min 31.7 gpm	35 MPa 5076 psi	1.015.15

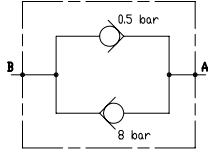
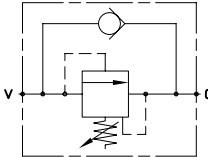
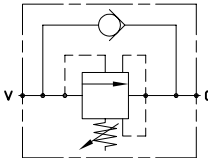
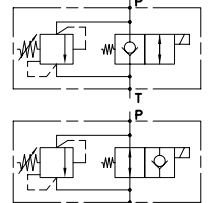
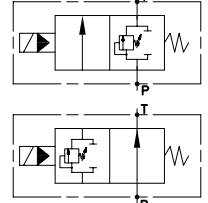
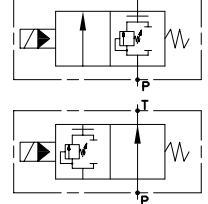
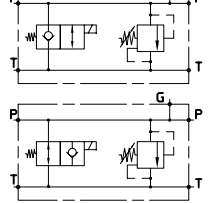
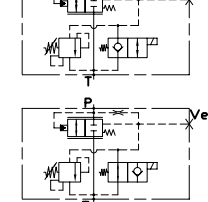
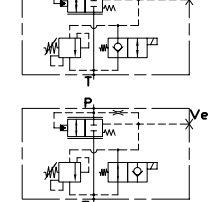
Scheme Schema	Description Bezeichnung	max flow max Durchfluß	max pressure max Arbeitsdruck	page Seite
	GUD	80 l/min 21.1 gpm	40 MPa 5689 psi	1.020.01
	GSQ-20-LM-38 GSQ-20-LM-12 GSQ-31-2 GSQ-24 GSQ-150-2-3	50 l/min - 13.2 gpm 80 l/min - 21.1 gpm 30 l/min - 7.9 gpm 80 l/min - 21.1 gpm 150 l/min - 39.6 gpm	35 MPa 5076 psi	1.020.11 1.020.12 1.021.02 1.021.50 1.022.01
	GSQ-31I-2 GSQ-24I GSQ-24I-82 GSQ-150I-2-3	30 l/min - 7.9 gpm 80 l/min - 21.1 gpm 80 l/min - 21.1 gpm 150 l/min - 39.6 gpm	35 MPa 5076 psi	1.021.03 1.021.52 1.021.55 1.022.02
	GVS-BP-PM208-SA-SC	30 l/min 7.9 gpm	35 MPa 5076 psi	1.040.02
	GVS-BP-GSVR-150-SA-SC-34	150 l/min 39.6 gpm	35 MPa 5076 psi	1.040.06
	GVS-BP-GSVRT-150-SB-34	150 l/min 39.6 gpm	35 MPa 5076 psi	1.040.07
	GVS-BP-VMG80-SA-SC	80 l/min 21.1 gpm	35 MPa 5076 psi	1.041.03
	GVS-BP-VCC-PM208-SA-SC	200 l/min 52.8 gpm	35 MPa 5076 psi	1.042.10
	GVS-BP-VCC-PM005-SA-SC			1.042.11

**TECHNICAL DATA
TECHNISCHE ANGABEN**

Max operating pressure Maximaler Betriebsdruck	35 MPa 5076 psi
Max flow Volumenstrom	60 l/min 15.8 gpm
Temperature range Betriebstemperatur	-20°/80°C
Filtration Filtergrad	40µ

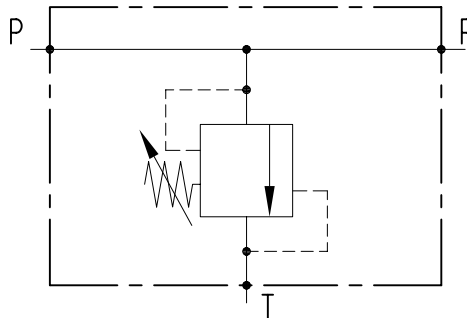
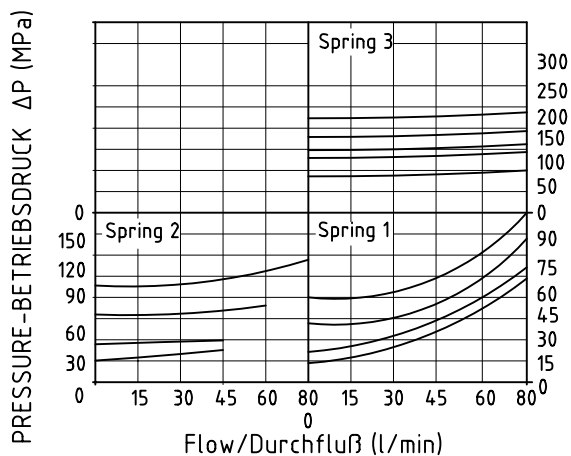
Diagram/Diagramm

Adjustment options/Einstellung

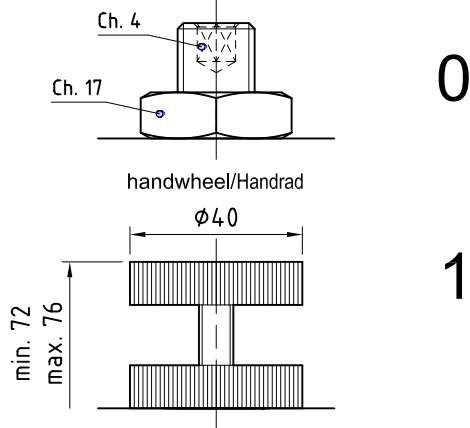
leakproof socket screw/ leckölfreie Regulierungsschraube

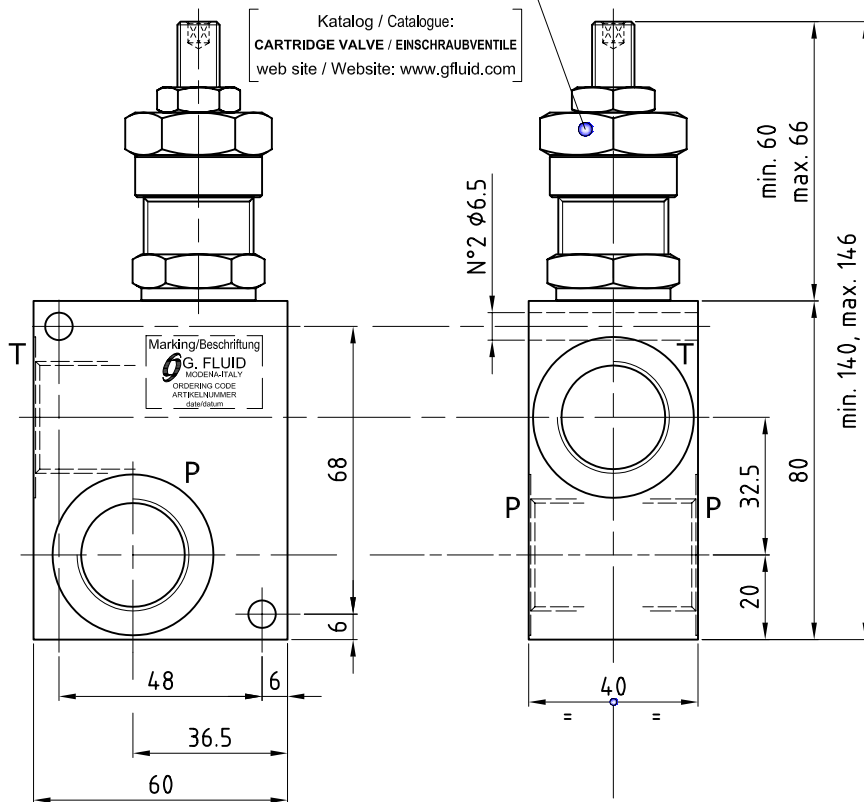

VMG80

 Katalog / Catalogue:
CARTRIDGE VALVE / EINSCHRAUBVENTILE
 web site / Website: www.gfluid.com

ORDERING CODE - ARTIKELNUMMER
1240113 0

Port size/Gewinde P, T	Adjustment options Einstellung	Adj. range Regelbereich	std setting Standardeinst.	Pressure increase MPa/turn Drucksteigerung MPa/je Schraubendrehung	Material Material	Weight Gewicht
4 5	0 1	1 2 3	5 MPa 10 MPa 20 MPa	0.4 0.8 3.5	0 Zincoated Steel Verzinkter Stahl	1.7 kg

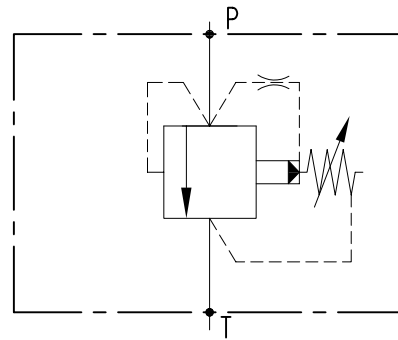
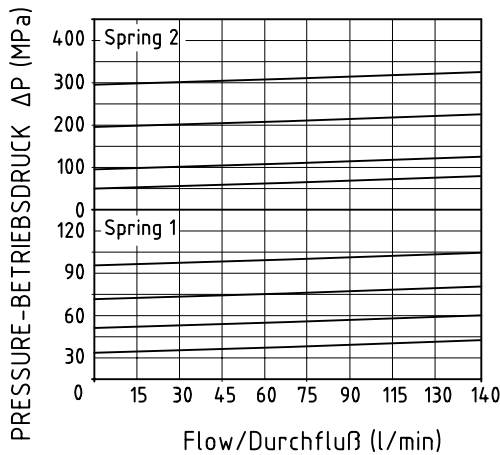
**TECHNICAL DATA
TECHNISCHE ANGABEN**

Max operating pressure Maximaler Betriebsdruck	35 MPa 5076 psi
Max flow Volumenstrom	150 l/min 39.6 gpm
Temperature range Betriebstemperatur	-20°/80°C
Filtration Filtergrad	40µ

Diagram/Diagramm

Adjustment options/Einstellung

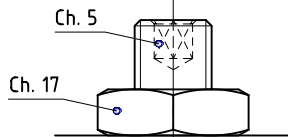
leakproof socket screw/ leckölfreie Regulierungsschraube

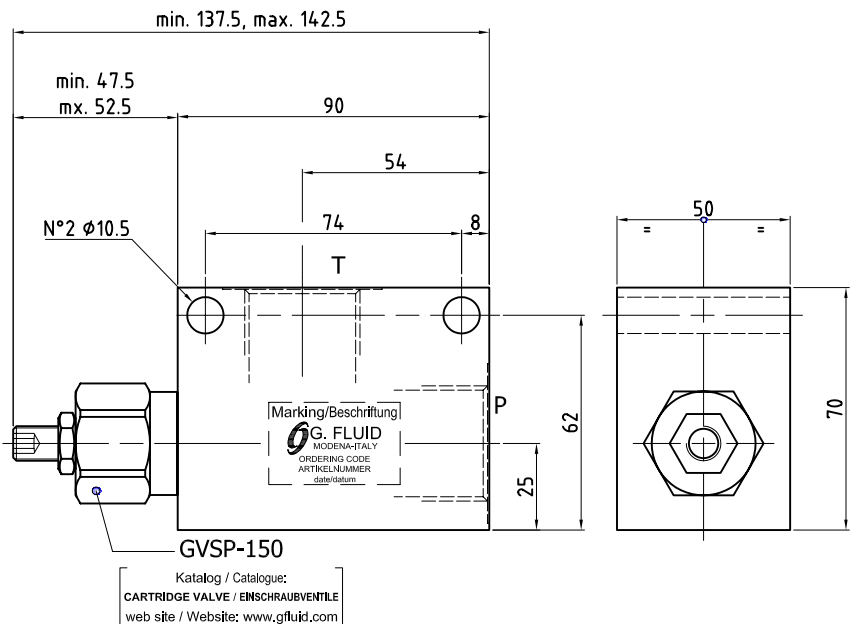
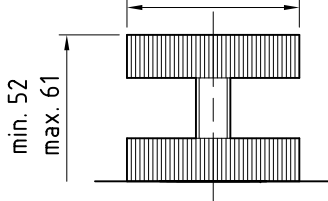

handwheel/Handrad

 $\phi 40$

ORDERING CODE - ARTIKELNUMMER
1240114 0

<table border="1"> <tr><th colspan="2">Port size/Gewinde P, T</th></tr> <tr><td>4</td><td>G 1/2"</td></tr> <tr><td>5</td><td>G 3/4"</td></tr> <tr><td>6</td><td>G 1"</td></tr> </table>	Port size/Gewinde P, T		4	G 1/2"	5	G 3/4"	6	G 1"	<table border="1"> <tr><th colspan="2">Adjustment options Einstellung</th></tr> <tr><td>0</td><td>leakproof socket screw leckölfreie Regulierungsschraube</td></tr> <tr><td>1</td><td>handwheel/Handrad</td></tr> </table>	Adjustment options Einstellung		0	leakproof socket screw leckölfreie Regulierungsschraube	1	handwheel/Handrad	<table border="1"> <tr> <th>Adj. range Regelbereich</th> <th>std setting Standardeinst.</th> <th>Pressure increase MPa/turn Drucksteigerung MPa je Schraubendrehung</th> </tr> <tr> <td>1 1-10 MPa</td> <td>8 MPa</td> <td>0.8</td> </tr> <tr> <td>2 5-45 MPa</td> <td>25 MPa</td> <td>4.5</td> </tr> </table>	Adj. range Regelbereich	std setting Standardeinst.	Pressure increase MPa/turn Drucksteigerung MPa je Schraubendrehung	1 1-10 MPa	8 MPa	0.8	2 5-45 MPa	25 MPa	4.5	<table border="1"> <tr> <th>Material Material</th> <th>Weight Gewicht</th> </tr> <tr> <td>0 Zincoated Steel Verzinkter Stahl</td> <td>2.6 kg</td> </tr> </table>	Material Material	Weight Gewicht	0 Zincoated Steel Verzinkter Stahl	2.6 kg
Port size/Gewinde P, T																														
4	G 1/2"																													
5	G 3/4"																													
6	G 1"																													
Adjustment options Einstellung																														
0	leakproof socket screw leckölfreie Regulierungsschraube																													
1	handwheel/Handrad																													
Adj. range Regelbereich	std setting Standardeinst.	Pressure increase MPa/turn Drucksteigerung MPa je Schraubendrehung																												
1 1-10 MPa	8 MPa	0.8																												
2 5-45 MPa	25 MPa	4.5																												
Material Material	Weight Gewicht																													
0 Zincoated Steel Verzinkter Stahl	2.6 kg																													

**TECHNICAL DATA
TECHNISCHE ANGABEN**

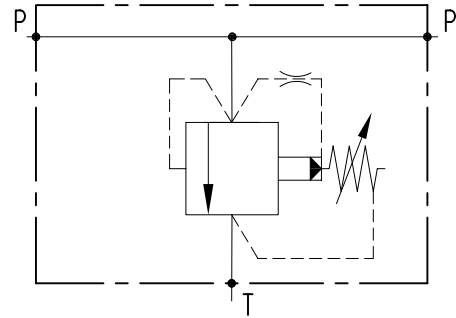
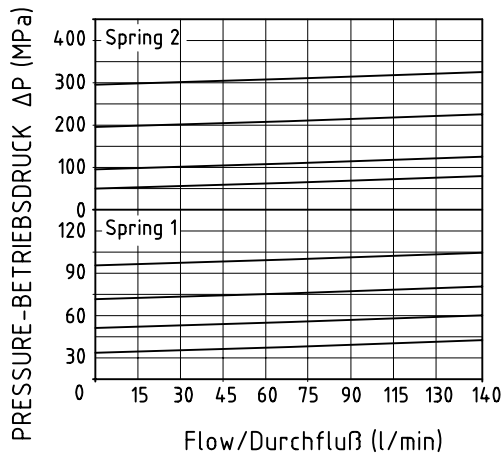
Max operating pressure Maximaler Betriebsdruck	21 MPa 3045 psi
Max flow Volumenstrom	150 l/min 39.6 gpm
Temperature range Betriebstemperatur	-20°/80°C
Filtration Filtergrad	40µ

Diagram/Diagramm

Adjustment options/Einstellung

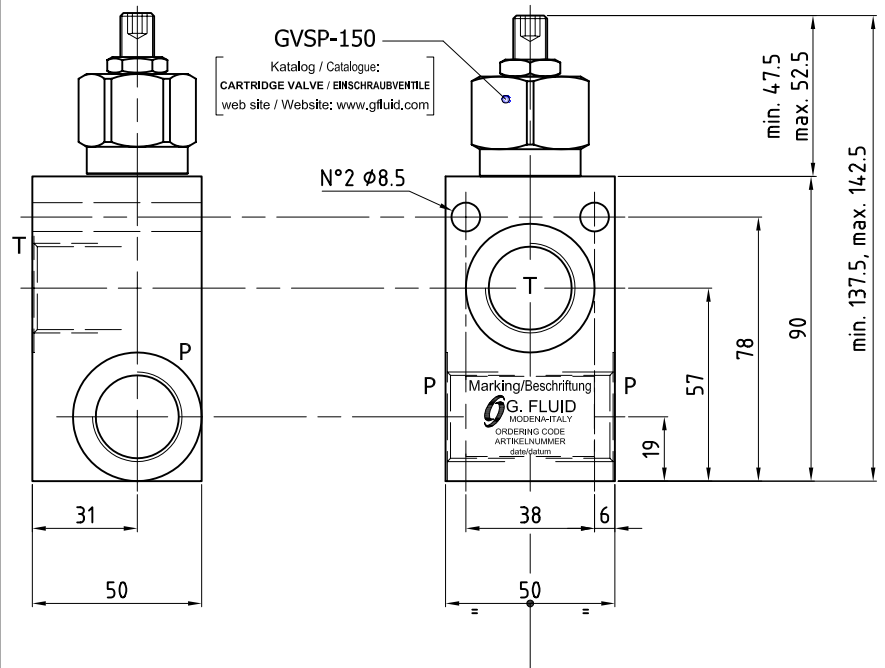
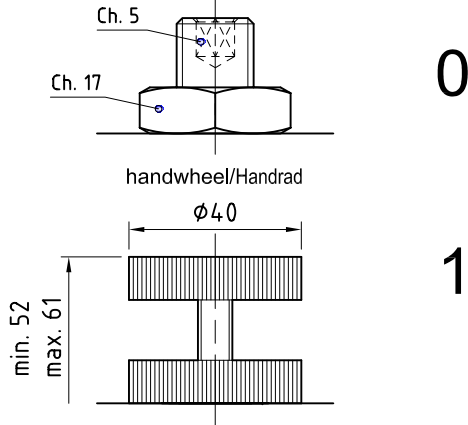
leakproof socket screw/ leckölfreie Regulierungsschraube



ORDERING CODE - ARTIKELNUMMER
1240214 0

5	Port size/Gewinde P, T G 3/4"	0 1	Adjustment options Einstellung leakproof socket screw leckölfreie Regulierungsschraube handwheel/Handrad	1 2	Adj. range Regelbereich 1-10 MPa 5-45 MPa	std setting Standardeinst. 8 MPa 25 MPa	Pressure increase MPa/turn Drucksteigerung MPa/je Schraubendrehung 0.8 4.5	0	Material Material Alloy/Aluminium	Weight Gewicht 0.8 kg
----------	-------------------------------------	----------------------	--	----------------------	--	--	--	----------	---	-----------------------------

GVS-SD-150

TECHNICAL DATA TECHNISCHE ANGABEN

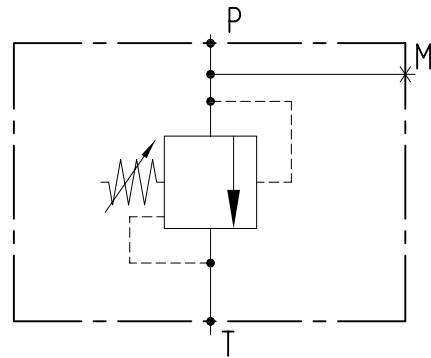
Max operating pressure Maximaler Betriebsdruck	21 MPa-2987 psi (Alloy/Aluminium) 35 MPa-5076 psi (Zincoated Steel/Verzink. Stahl)
Max flow Volumenstrom	150 l/min 39.6 gpm
Temperature range Betriebstemperatur	-20°/80°C
Filtration Filtergrad	40µ

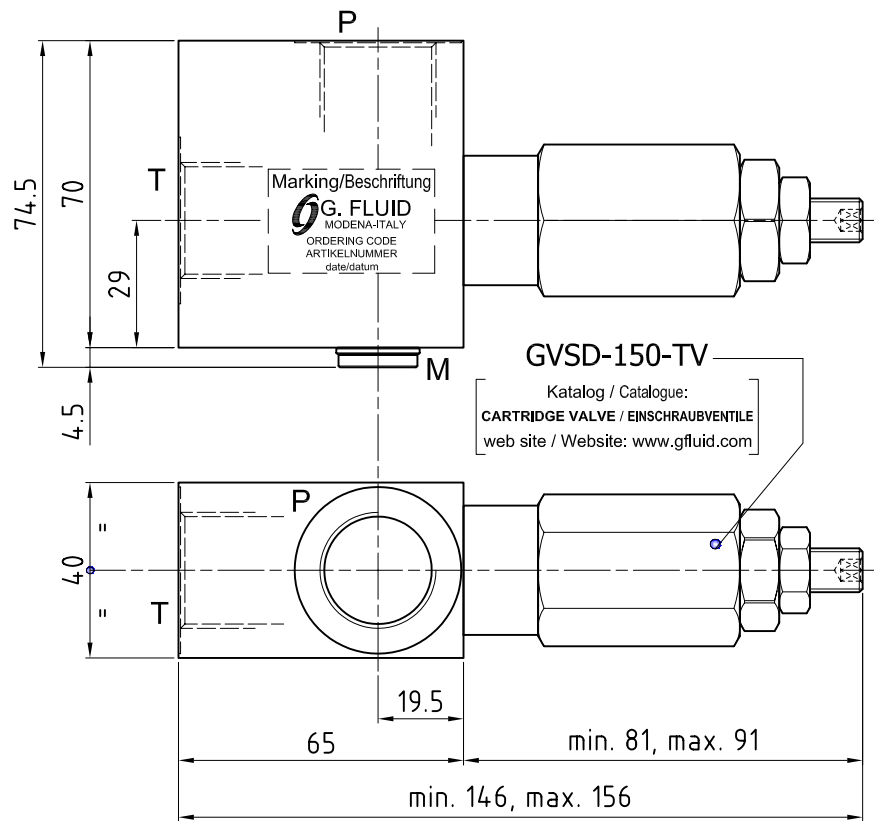
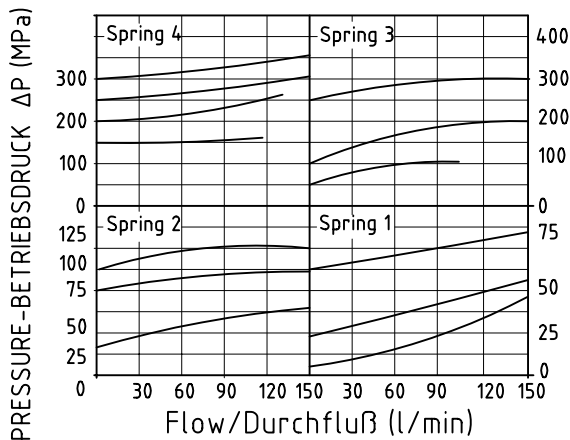

Diagram/Diagramm

GVSD-150-TV

 Katalog / Catalogue:
CARTRIDGE VALVE / EINSCHRAUBVENTILE
 web site / Website: www.gfluid.com

Adjustment options/Einstellung

leakproof socket screw/ leckölfreie Regulierungsschraube

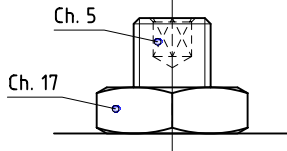

closure cap/Verschlusskappe

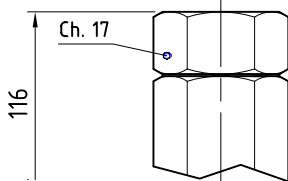

ORDERING CODE - ARTIKELNUMMER

1240324 0

3 G 1/2" G 1/4" 4 G 3/4" G 1/4"		0 leakproof socket screw 1 closure cap	2 0.5-5 MPa 2 MPa 3 7-21 MPa 20 MPa 4 13-35 MPa 30 MPa	Pressure increase MPa/tum Drucksteigerung MPa/je Schraubendrehung 0 0.4 1 6.5 2 6.5	0 Alloy/Aluminium 0.9 kg 1 Zincoated Steel 1.9 kg
--	--	---	--	---	--

GVS-SD-250

TECHNICAL DATA TECHNISCHE ANGABEN

Max operating pressure Maximaler Betriebsdruck	21 MPa-2987 psi (Alloy/Aluminium) 35 MPa-5076 psi (Zincoated Steel/Verzink. Stahl)
Max flow Volumenstrom	240 l/min 83.4 gpm
Temperature range Betriebstemperatur	-20°/80°C
Filtration Filtergrad	40µ

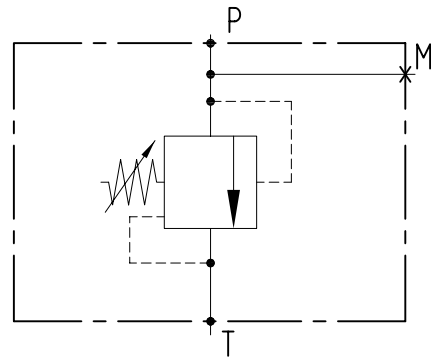

Diagram/Diagramm

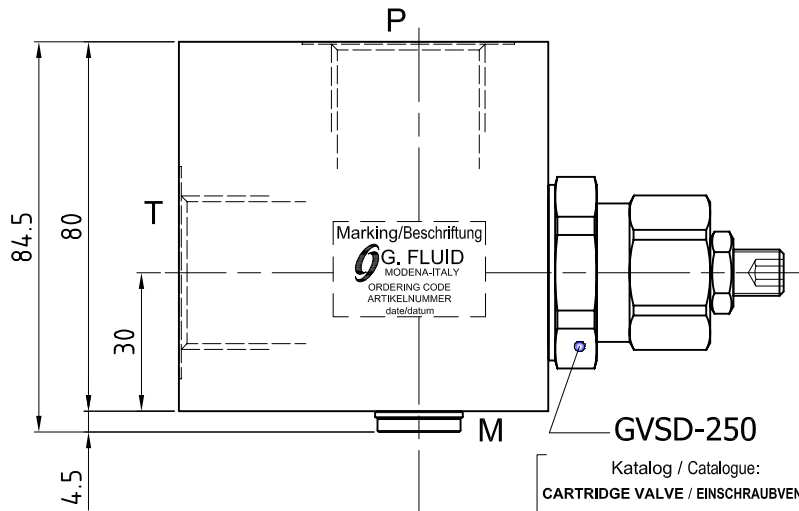
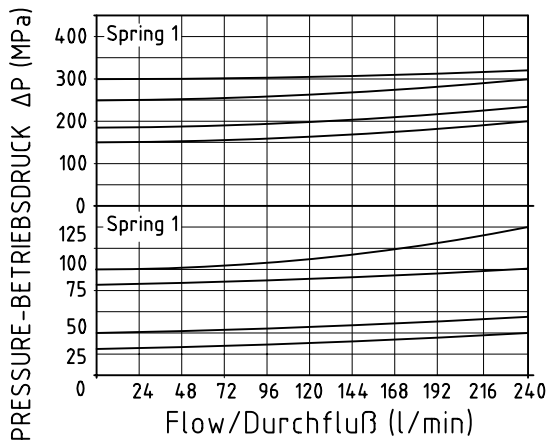
GVSD-250

 Katalog / Catalogue:
CARTRIDGE VALVE / EINSCHRAUBVENTILE
 web site / Website: www.gfluid.com

Adjustment options/Einstellung

leakproof socket screw/ leckölfreie Regulierungsschraube

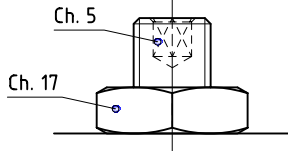
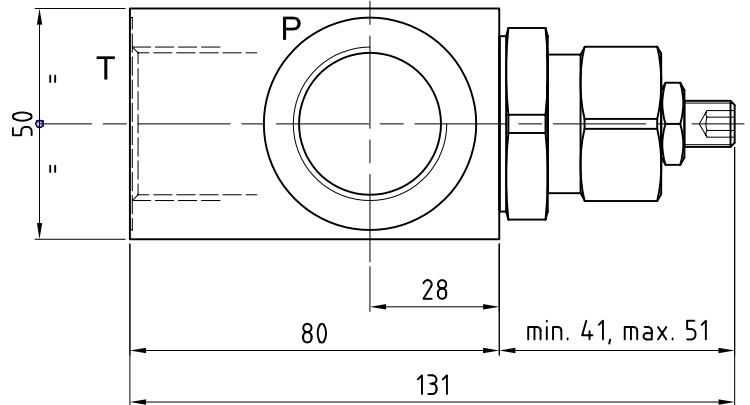
0

ORDERING CODE - ARTIKELNUMMER

1240325 0

Port size/Gewinde P, T M		Adjustment options Einstellung	Adj. range Regelbereich	std setting Standardeinst.	Pressure increase MPa/turn Drucksteigerung MPa je Schraubendrehung	Material Material	Weight Gewicht
4	G 3/4"	0 leakproof socket screw leckölfreie Regulierungsschraube	1	2-12 MPa	10 MPa	0 Alloy/Aluminium	1.8 kg
5	G 1"		2	10-35 MPa	35 MPa		1 Zincoated Steel Verzinkter Stahl

TECHNICAL DATA
TECHNISCHE ANGABEN

Max operating pressure Maximaler Betriebsdruck	21 MPa-2987 psi (Alloy/Alumin.) 35 MPa-5076 psi (Zincoated Steel/Verzink. Stahl)
Max flow Volumenstrom	20 l/min 5.3 gpm
Temperature range Betriebstemperatur	-20°/80°C
Filtration Filtergrad	40µ

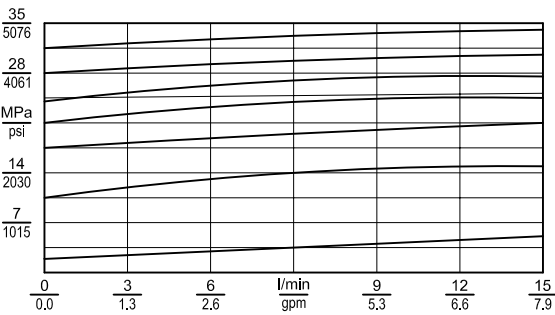
Diagram/Diagramm

Adjustment options/Einstellung

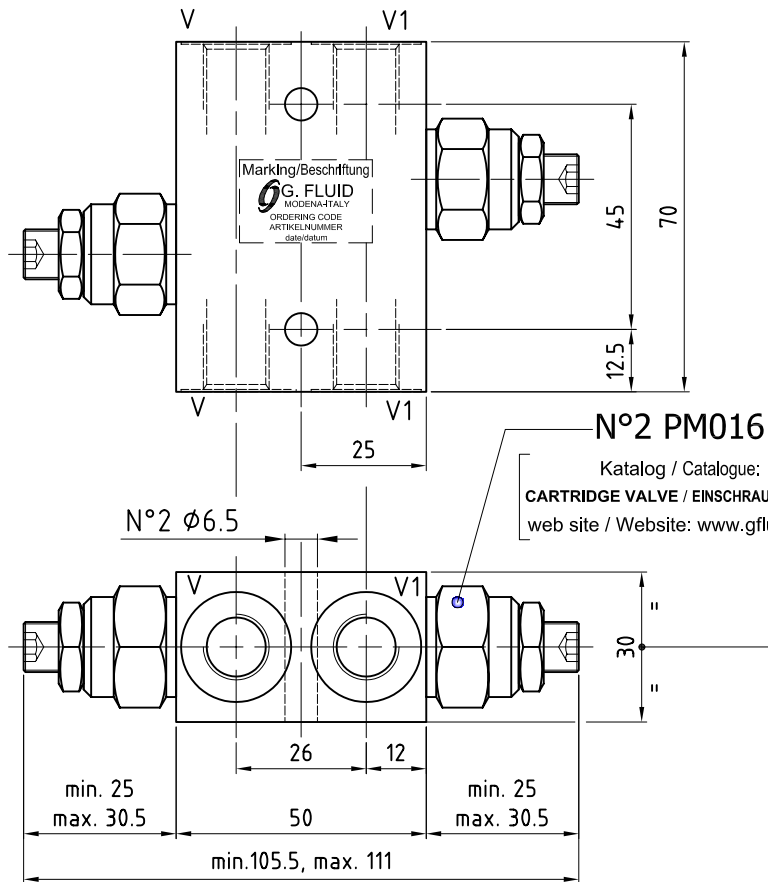
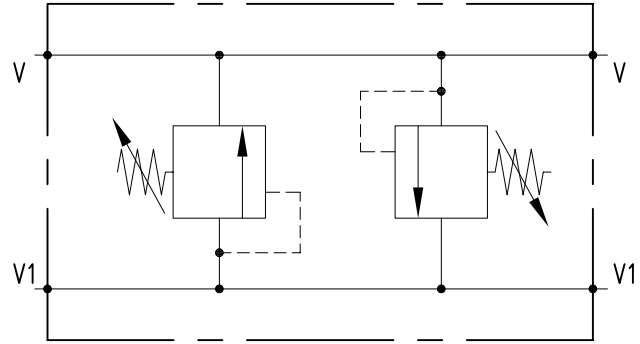
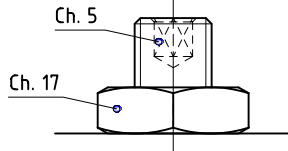
leakproof socket screw/ leckölfreie Regulierungsschraube

ORDERING CODE - ARTIKELNUMMER
20505100 00

1	Port size/Gewinde P, T G 1/4"	1	Adj. range Regelbereich 2-15 MPa	std setting Standardeinst. 10 MPa	Pressure increase MPa/turn Drucksteigerung MPa je Schraubendrehung 1.6	0	Adjustment options Einstellung leakproof socket screw leckölfreie Regulierungsschraube	0	Material Material Alloy/Aluminium	Weight Gewicht 0.4 kg
2		2	10-35 MPa	35 MPa	4.4	1		1	Zincoated Steel Verzinkter Stahl	1.0 kg

TECHNICAL DATA
TECHNISCHE ANGABEN

Max operating pressure Maximaler Betriebsdruck	21 MPa-2987 psi (Alloy/Aluminium) 35 MPa-5076 psi (Zincoated Steel/Verzink. Stahl) 35 MPa-5076 psi (Stainless steel/Edelstahl)
Max flow Volumenstrom	20 l/min 5.3 gpm
Temperature range Betriebstemperatur	-20°/80°C
Filtration Filtergrad	40µ

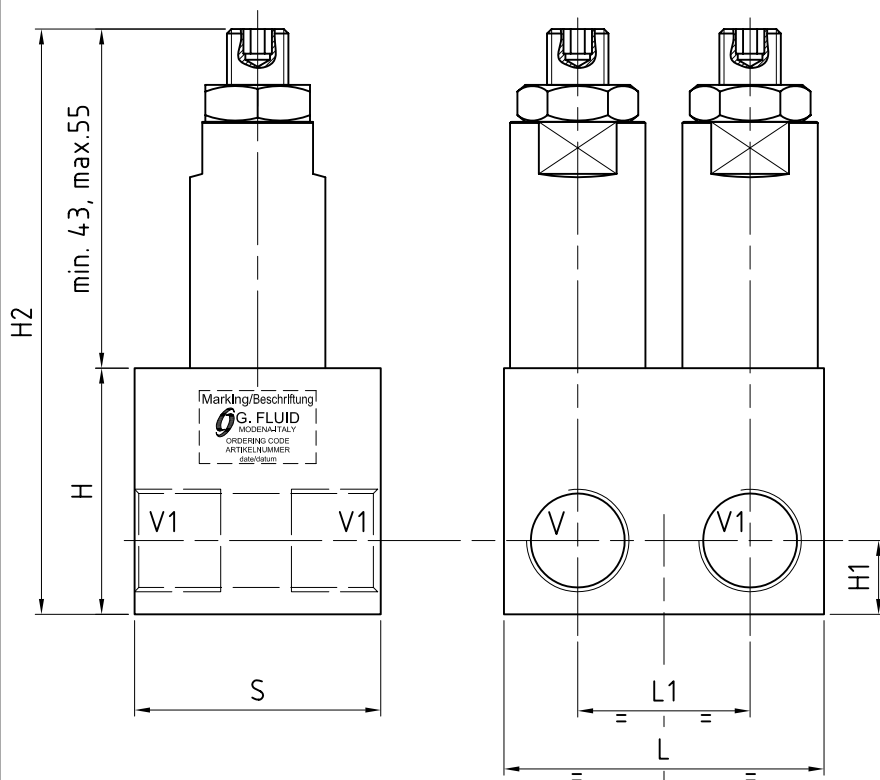
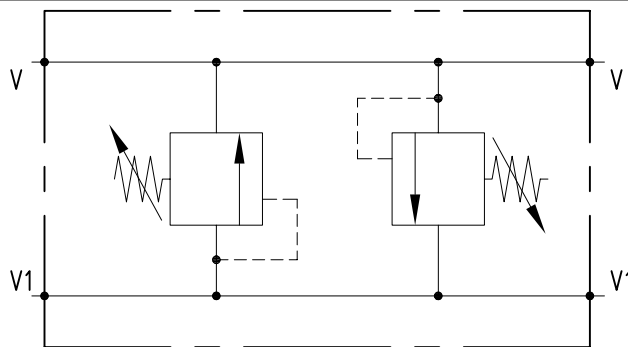

V, V1	L	L1	S	H	H1	H2
G 1/4"	52	28	39.5	40	12	min. 87
G 3/8"						max. 95
G 1/2"	68	38	49	49	15	min. 96, max. 104

ORDERING CODE - ARTIKELNUMMER
20538100 01

	Port size/Gewinde V, V1	Adj. range Regelbereich	std setting Standardeinst.	Pressure increase MPa/turn Drucksteigerung MPa je Schraubendrehung	Adjustment options Einstellung	Material Material	Weigth/Gewicht G 1/4"-3/8" G 1/2"	
1	G 1/4"	1 1-5 MPa	5 5 MPa	0.5	0 leakproof socket screw lecköffreie Regulierungsschraube	0 Alloy/Aluminium	0.3 kg	0.4 kg
2	G 3/8"	2 5-20 MPa	18 18 MPa	2.3		1 Zincoated Steel/ Verzinkter Stahl	0.7 kg	1.0 kg
3	G 1/2"	3 20-35 MPa	30 30 MPa	5.4		2 Stainless steel/ Edelstahl	0.6 kg	0.9 kg

TECHNICAL DATA
TECHNISCHE ANGABEN

Max operating pressure Maximaler Betriebsdruck	21 MPa-2987 psi (Alloy/Alumin.) 35 MPa-5076 psi (Zincoated Steel/Verzink. Stahl)
Max flow Volumenstrom	30 l/min 7.9 gpm
Temperature range Betriebstemperatur	-20°/80°C
Filtration Filtergrad	40µ

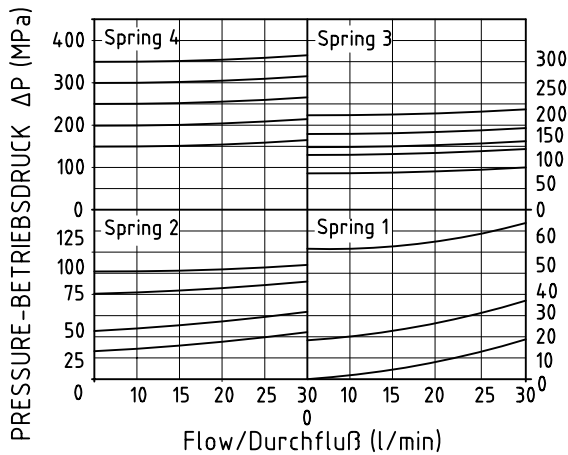
Diagram/Diagramm

Adjustment options/Einstellung

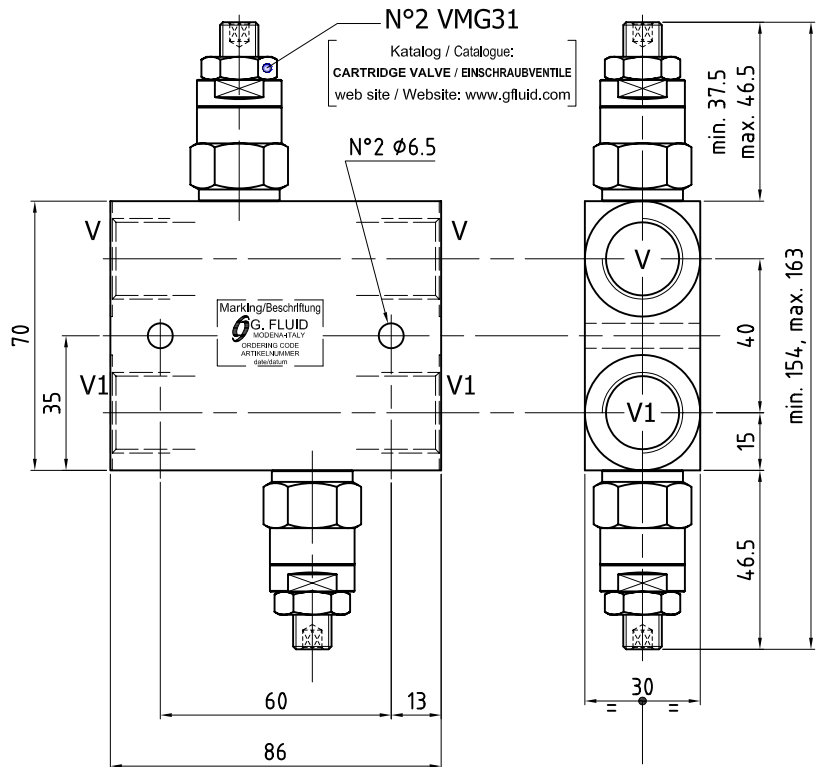
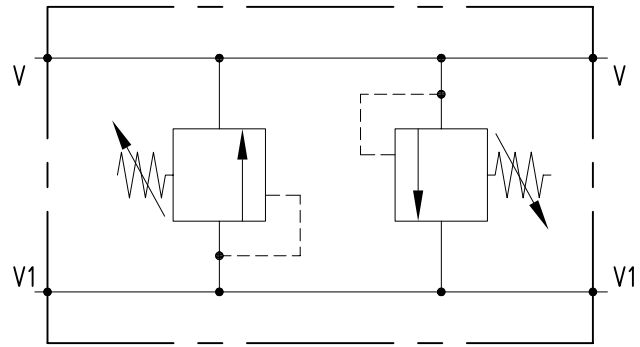
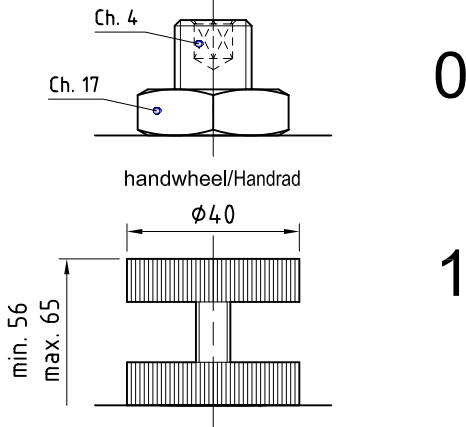
leakproof socket screw/ leckölfreie Regulierungsschraube

ORDERING CODE - ARTIKELNUMMER
20521100 00

Port size/Gewinde V, V1	Adj. range Regelbereich	std setting Standardeinst.	Pressure increase MPa/turn Drucksteigerung MPa je Schraubendrehung	Adjustment options Einstellung	Material Material	Weight Gewicht
2 G 3/8"	1 1-6 MPa	6 MPa	1.0	0 leakproof socket screw leckölfreie Regulierungsschraube	0 Alloy/Aluminium	0.7 kg
3 G 1/2"	2 5-21 MPa	20 MPa	2.8	1 handwheel/Handrad	1 Zincoated Steel/ Verzinkter Stahl	1.7 kg
	3 10-35 MPa	35 MPa	6.6			

TECHNICAL DATA
TECHNISCHE ANGABEN

Max operating pressure Maximaler Betriebsdruck	25 MPa-2987 psi (Alloy/Alumin.) 35 MPa-5076 psi (Zincoated Steel/Verzink. Stahl)
Max flow Volumenstrom	30 l/min 7.9 gpm
Temperature range Betriebstemperatur	-20°/80°C
Filtration Filtergrad	40µ

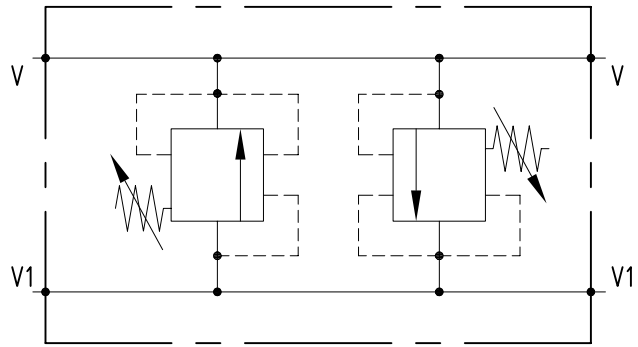
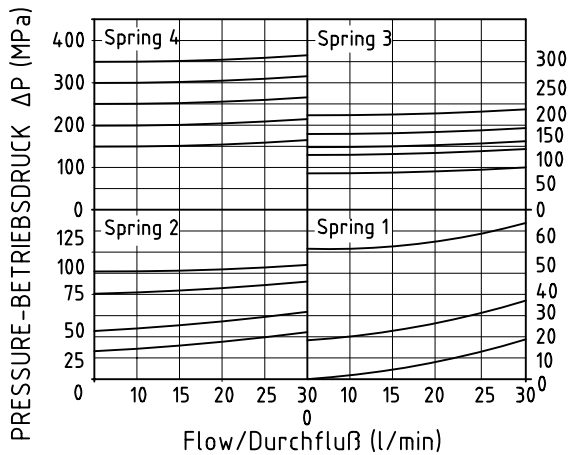
Diagram/Diagramm

Adjustment options/Einstellung
closure cap/Verschlusskappe

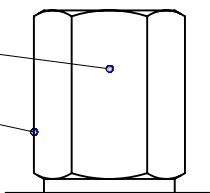
inner socket
screw hex. 5
Reg. Schraube innen:
Sechskant 5

2

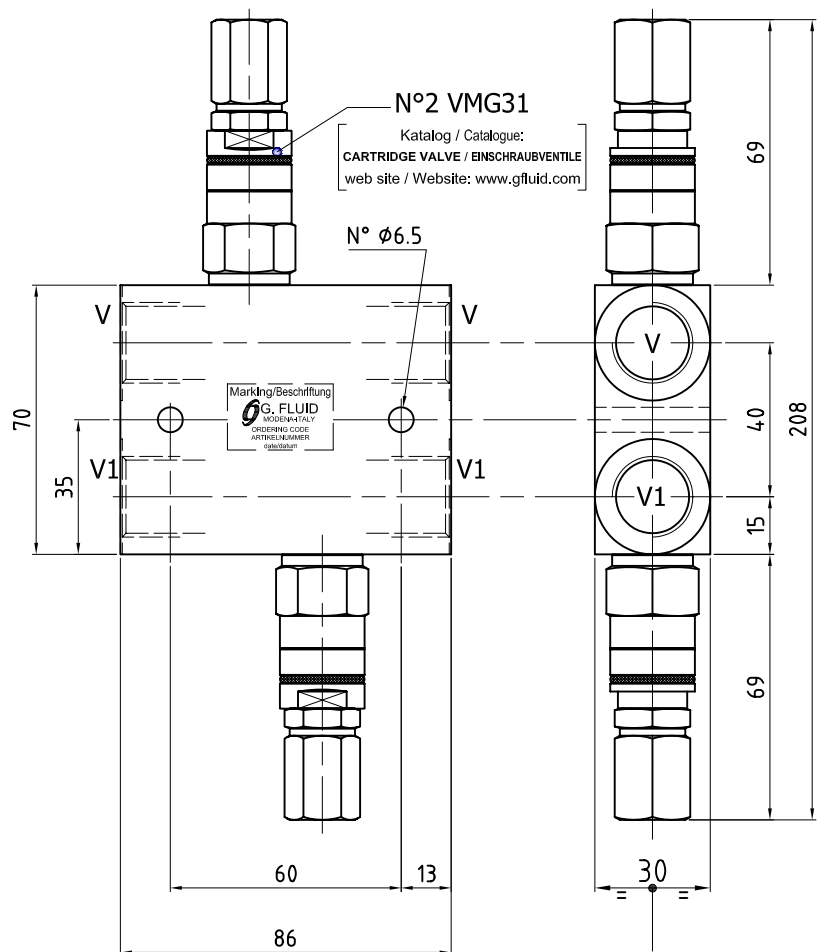
Ch. 17

ORDERING CODE - ARTIKELNUMMER
20523100 00

	Port size/Gewinde V, V1	Adj. range Regelbereich	std setting Standardeinst.	Pressure increase MPa/turn Drucksteigerung MPa je Schraubendrehung	Adjustment options Einstellung	Material Material	Weigth Gewicht
2	G 3/8"	1 1-6 MPa	6 MPa	1.0	2 closure cap/Verschlusskappe	0 Alloy/Aluminium	0.7 kg
3	G 1/2"	2 5-21 MPa	20 MPa	2.8		1 Zincoated Steel/ Verzinkter Stahl	1.7 kg
		3 10-35 MPa	35 MPa	6.6			

TECHNICAL DATA
TECHNISCHE ANGABEN

Max operating pressure Maximaler Betriebsdruck	21 MPa-2987 psi (Alloy/Alumin.) 35 MPa-5076 psi (Zincoated Steel/Verzink. Stahl)
Max flow Volumenstrom	60 l/min 15.8 gpm
Temperature range Betriebstemperatur	-20°/80°C
Filtration Filtergrad	40µ

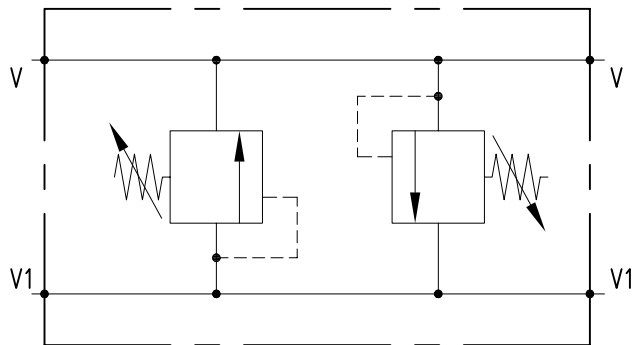
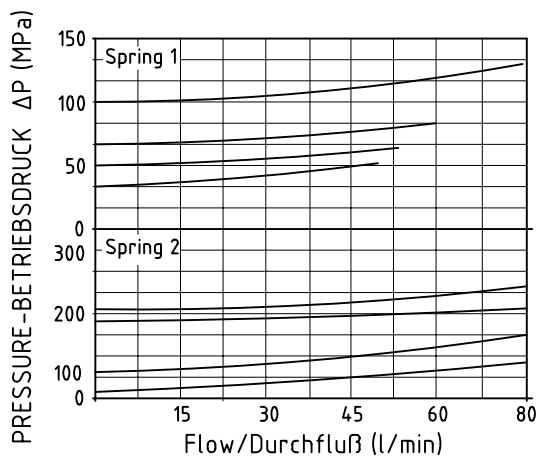
Diagram/Diagramm

Adjustment options/Einstellung

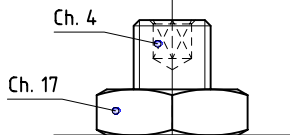
leakproof socket screw/ leckölfreie Regulierungsschraube

0

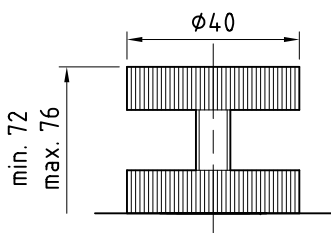
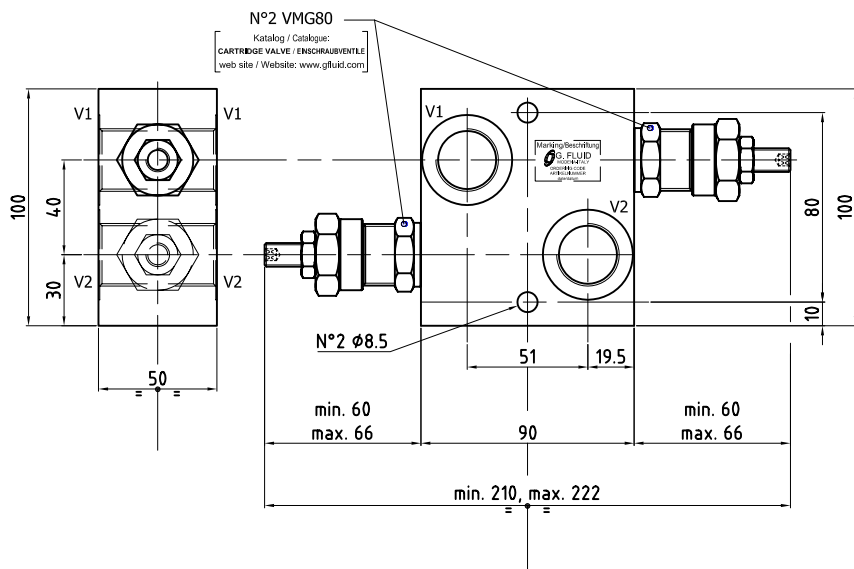
handwheel/Handrad

1

ORDERING CODE - ARTIKELNUMMER
20529100 00

	Port size/Gewinde V, V1	Adj. range Regelbereich	std setting Standardeinst.	Pressure increase MPa/turn Drucksteigerung MPa je Schraubendrehung	Adjustment options Einstellung	Material Material	Weight Gewicht
3	G 1/2"	1 3.5-10 MPa	10 MPa	0.8	0 leakproof socket screw leckölfreie Regulierungsschraube	0 Alloy/Aluminium	1.6 kg
4	G 3/4"	2 8-25 MPa	20 MPa	3.5	1 handwheel/Handrad	1 Zincoated Steel/ Verzinkter Stahl	3.7 kg

TECHNICAL DATA
TECHNISCHE ANGABEN

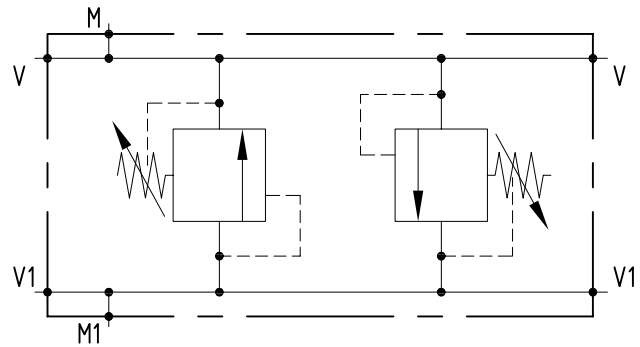
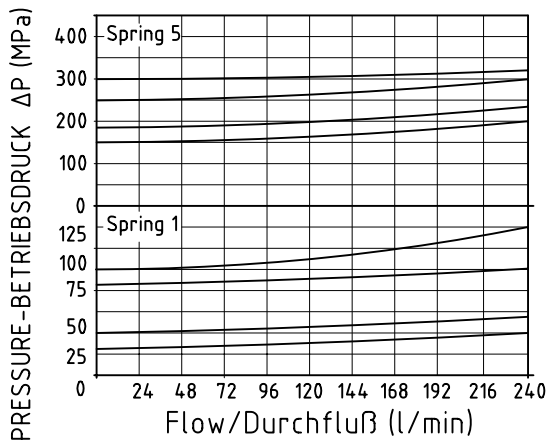
Max operating pressure Maximaler Betriebsdruck	35 MPa 5076 psi
Max flow Volumenstrom	240 l/min 63.4 gpm
Temperature range Betriebstemperatur	-20°/80°C
Filtration Filtergrad	40µ
Material/Material Weigth/Gewicht	Zincoated steel/Verzinkter Stahl 6.0 kg

Diagram/Diagramm

Adjustment options/Einstellung

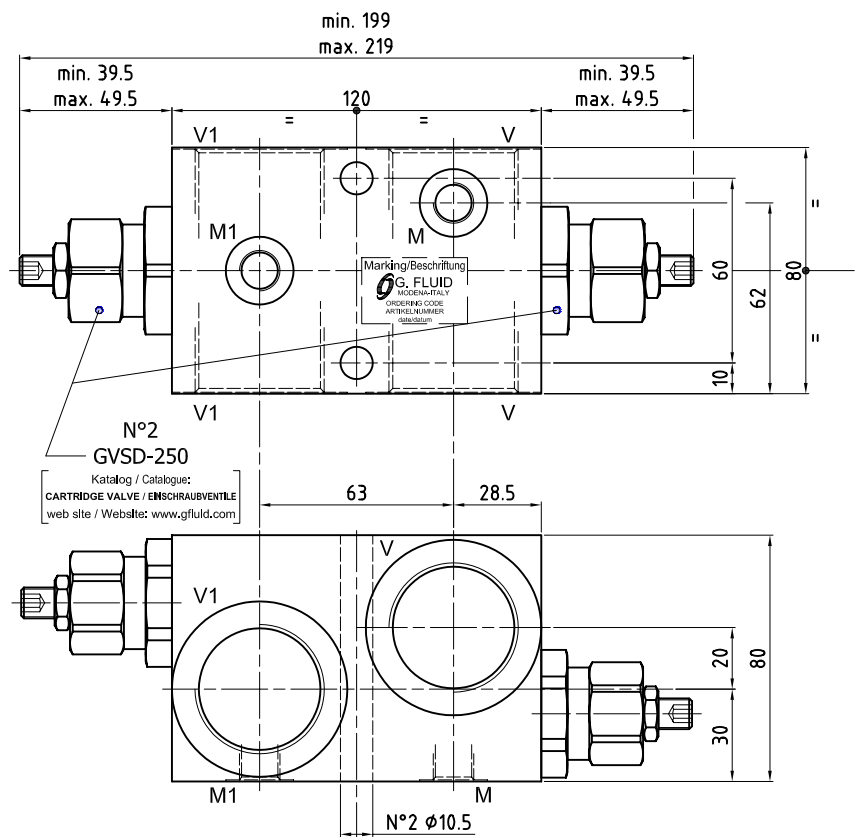
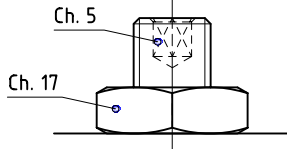
leakproof socket screw/ leckölfreie Regulierungsschraube



ORDERING CODE - ARTIKELNUMMER
20536110 00

Port size/Gewinde V, V1, V, V1 M, M1		Adj. range Regelbereich	std setting Standardeinst.	Pressure increase MPa/turn Drucksteigerung MPa je Schraubendrehung	Adjustment options Einstellung	Material Material	Weigth Gewicht
6	G 1 1/4" G 1/4"	1 5	2-12 MPa 10 MPa 35 MPa	1.6 4.4	0 leakproof socket screw leckölfreie Regulierungsschraube	1 Zincoated Steel Verzinkter Stahl	6.0 kg

GVS-DI-80-30

TECHNICAL DATA
TECHNISCHE ANGABEN

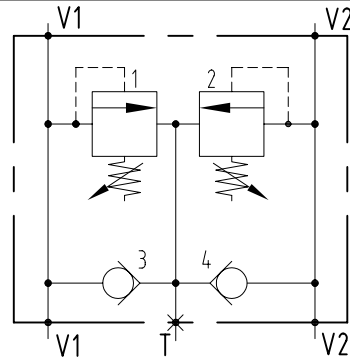
Max operating pressure Maximaler Betriebsdruck	21 MPa-2987 psi (Alloy/Alumin.) 35 MPa-5076 psi (Zincoated Steel/Verzink. Stahl)
Max flow Volumenstrom	60 l/min 15.8 gpm
Temperature range Betriebstemperatur	-20°/80°C
Filtration Filtergrad	40µ



Diagram/Diagramm

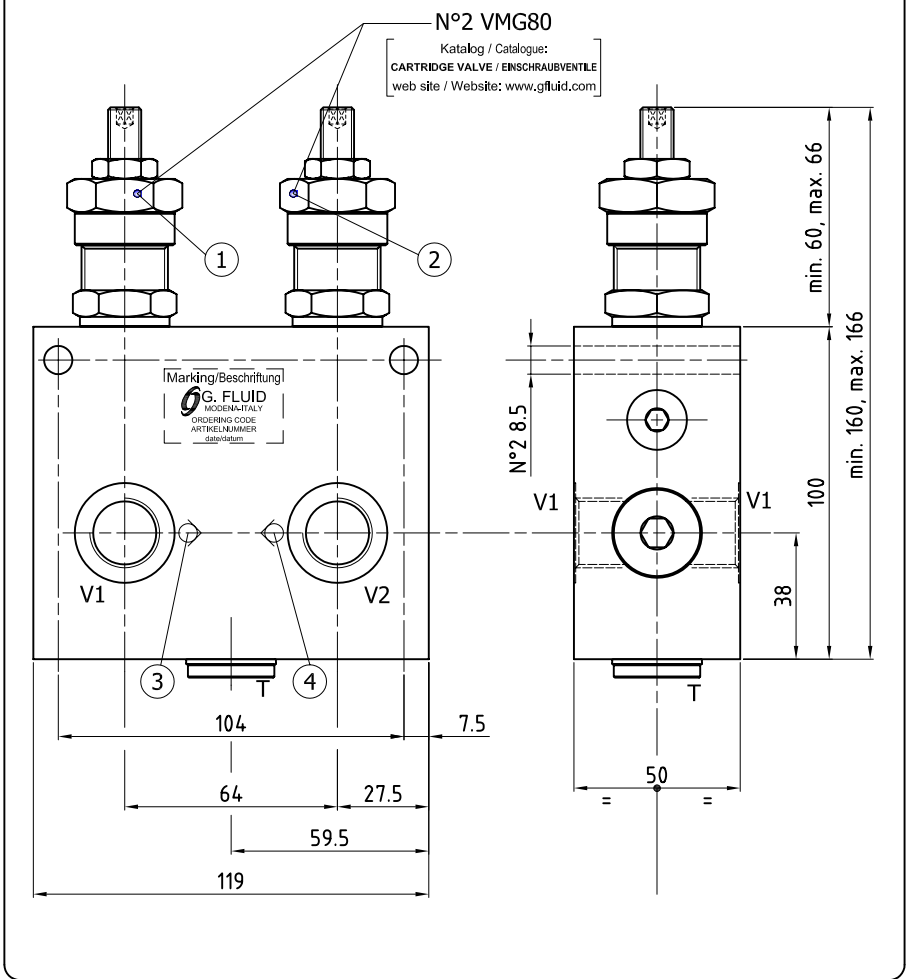
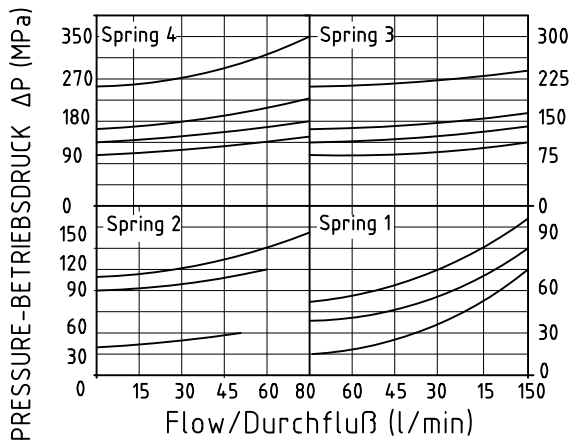

Adjustment options/Einstellung

leakproof socket screw/ leckölfreie Regulierungsschraube

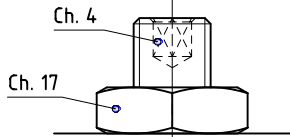

handwheel/Handrad

Ø40

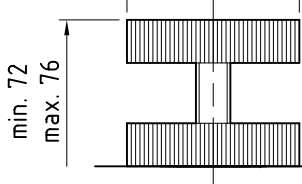

ORDERING CODE - ARTIKELNUMMER

20529300 00

3	Port size/Gewinde V1, V2 G 1/2"	1	Adj. range Regelbereich 0.5-5 MPa	5	std setting Standardeinst. 5 MPa	0	Pressure increase MPa/tum Drucksteigerung MPa je Schraubendrehung 0.5	0	Adjustment options Einstellung leakproof socket screw leckölfreie Regulierungsschraube	0	Material Material AlloyAluminium	2.1	Weight Gewicht 2.1 kg
		2	3.5-10 MPa	10	10 MPa	2.3		1	handknob and locknut Handrad und Mutter	1	Zincoated Steel/ Verzinkter Stahl	5.1	5.1 kg
		3	8-25 MPa	20	20 MPa	5.4							
		4	12-35 MPa	35	35 MPa	6.5							

TECHNICAL DATA
TECHNISCHE ANGABEN

Max operating pressure Maximaler Betriebsdruck	21 MPa-2987 psi (Alloy/Alumin.) 35 MPa-5076 psi (Zincoated Steel/Verzink. Stahl)
Max flow Volumenstrom	150 l/min 39.6 gpm
Temperature range Betriebstemperatur	-20°/80°C
Filtration Filtergrad	40µ

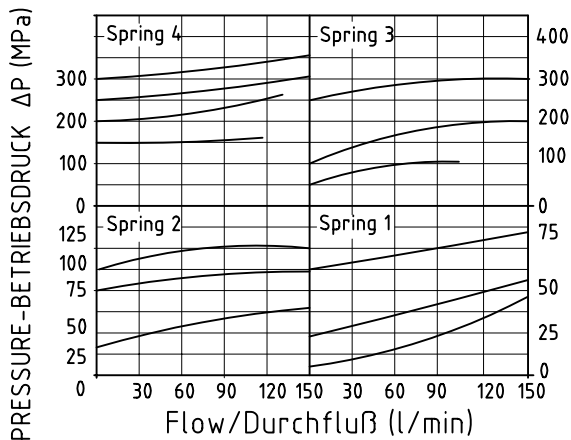
Diagram/Diagramm

Adjustment options/Einstellung

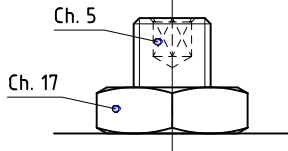
leakproof socket screw/ leckölfreie Regulierungsschraube

0

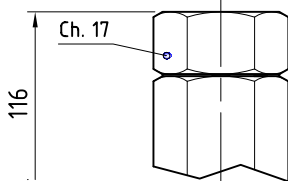
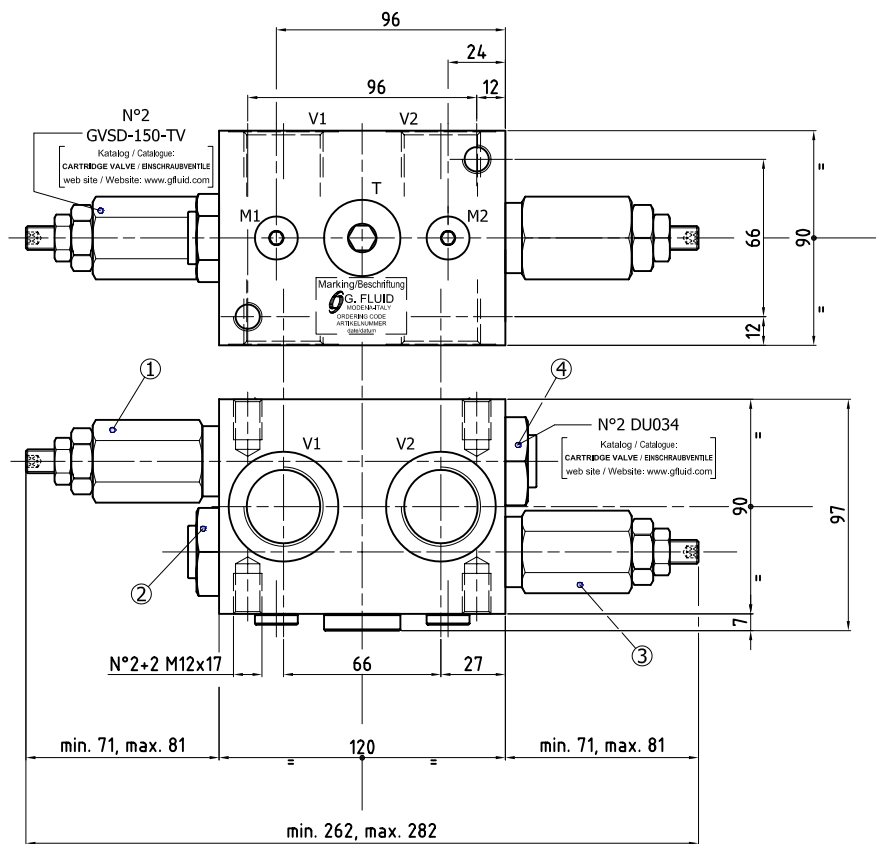
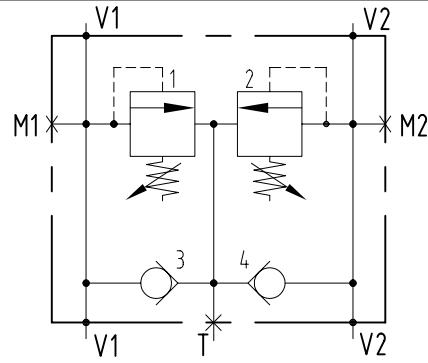
closure cap/Verschlusskappe

1

ORDERING CODE - ARTIKELNUMMER
20535310 01

Port size/Gewinde V1, V2 T M1, M2				Adj. range Regelbereich			std setting Standardeinst.			Pressure increase MPa/turn Drucksteigerung MPa je Schraubendrehung			Adjustment options Einstellung		Material Material		Weigth Gewicht	
5	G 1"	G 3/4"	G 1/4"	1	0.5-5 MPa	5 MPa	0.4	0	leakproof socket screw leckölfreie Regulierungsschraube		0	AlloyAluminium		2.8 kg				
6	G 1 1/4"	G 3/4"	G 1/4"	2	4-10 MPa	10 MPa	2.3	1	handknob and locknut Handrad und Mutter		1	Zincoated Steel/ Verzinkter Stahl		7.6 kg				
				3	7-21 MPa	20 MPa	6.5											
				4	13-35 MPa	35 MPa	6.5											

GVS-DI-150-70

TECHNICAL DATA TECHNISCHE ANGABEN

Max operating pressure Maximaler Betriebsdruck	21 MPa-2987 psi (Alloy/Alumin.) 35 MPa-5076 psi (Zincoated Steel/Verzink. Stahl)
Max flow Volumenstrom	150 l/min 39.6 gpm
Temperature range Betriebstemperatur	-20°/80°C
Filtration Filtergrad	40µ

Diagram/Diagramm

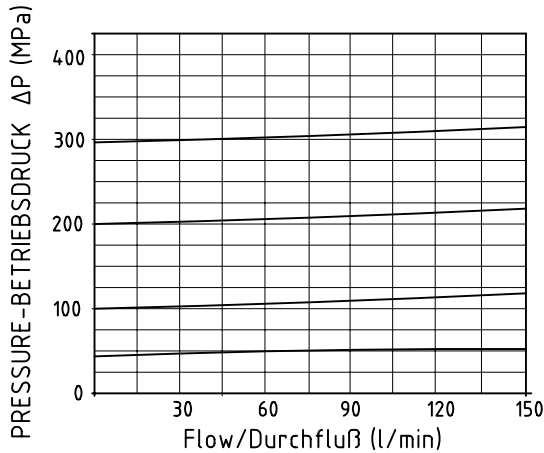

Adjustment options/Einstellung

leakproof socket screw/ leckölfreie Regulierungsschraube

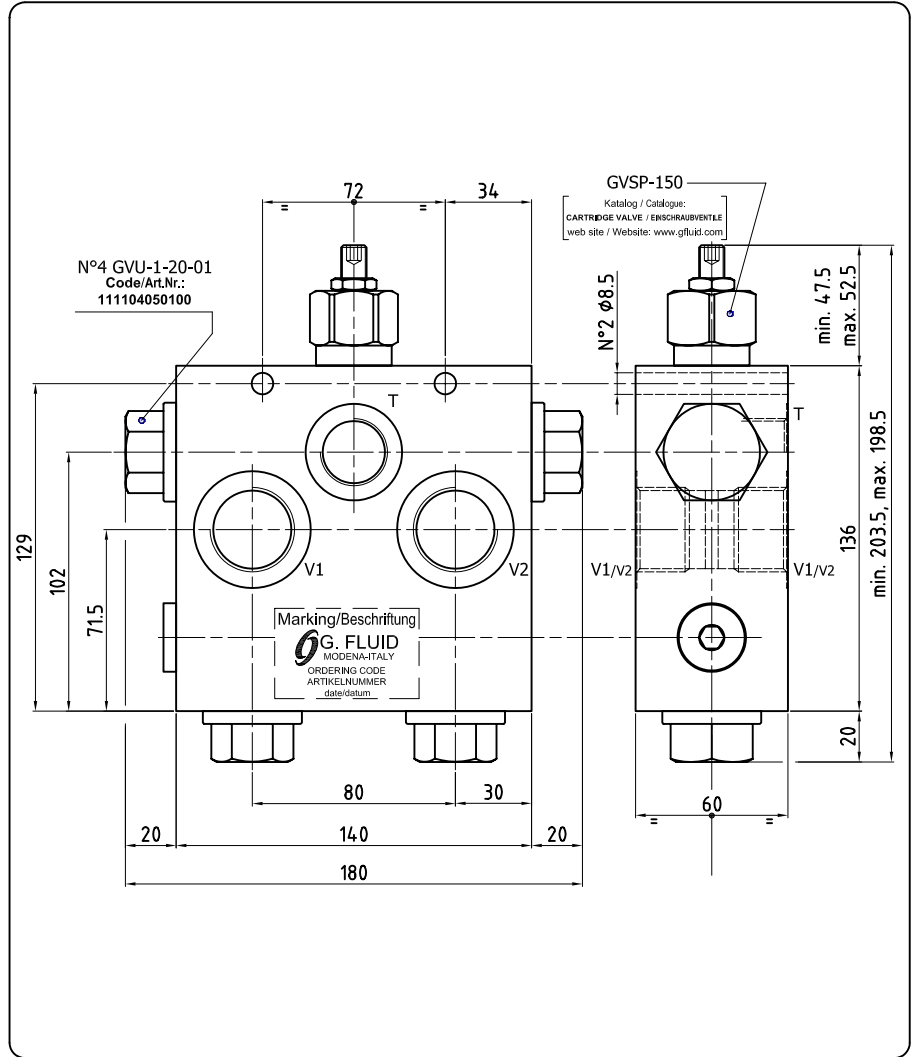
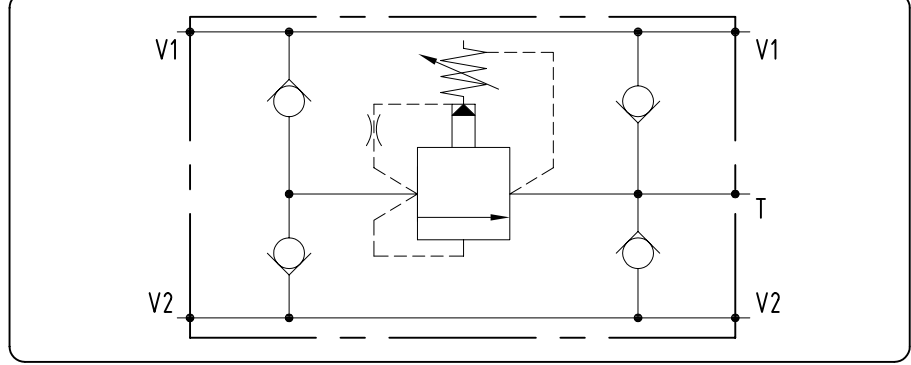
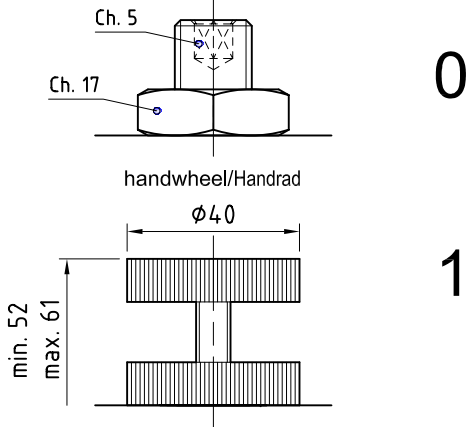

ORDERING CODE - ARTIKELNUMMER

20531700 01

3 4 5	Port size/Gewinde V1, V2 T		1 2	Adj. range Regelbereich	std setting Standardeinst.	Pressure increase MPa/turn Drucksteigerung MPa je Schraubendrehung	0 1	Adjustment options Einstellung		0 1	Material	Weight Gewicht
	G 1/2"	G 1/2"		1-10 MPa	8 MPa	0.8		leakproof socket screw leckölfreie Regulierungsschraube	AlloyAluminium		3.7 kg	
	G 3/4"	G 3/4"		5-45 MPa	25 MPa	4.5		handwheel/Handrad	Zincoated Steel/ Verzinkter Stahl		8.1 kg	

GRP-20-R

TECHNICAL DATA TECHNISCHE ANGABEN

Max operating pressure Maximaler Betriebsdruck	21 MPa-2987 psi (Alloy/Alumin.) 35 MPa-5076 psi (Zincoated Steel/Verzink. Stahl)
Max flow Volumenstrom	20 l/min 5.3 gpm
Max regulated pressure Max. Geregelter Druck	10.5 MPa 1500 psi
Temperature range Betriebstemperatur	-20°/80°C
Filtration Filtergrad	15µ

Diagram/Diagramm

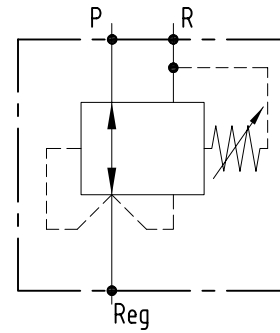
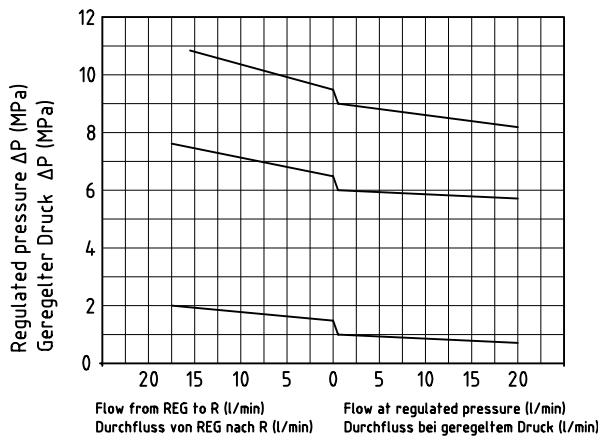

PR110

Katalog / Catalogue:
CARTRIDGE VALVE / EINSCHRAUBVENTILE
web site / Website: www.gfluid.com

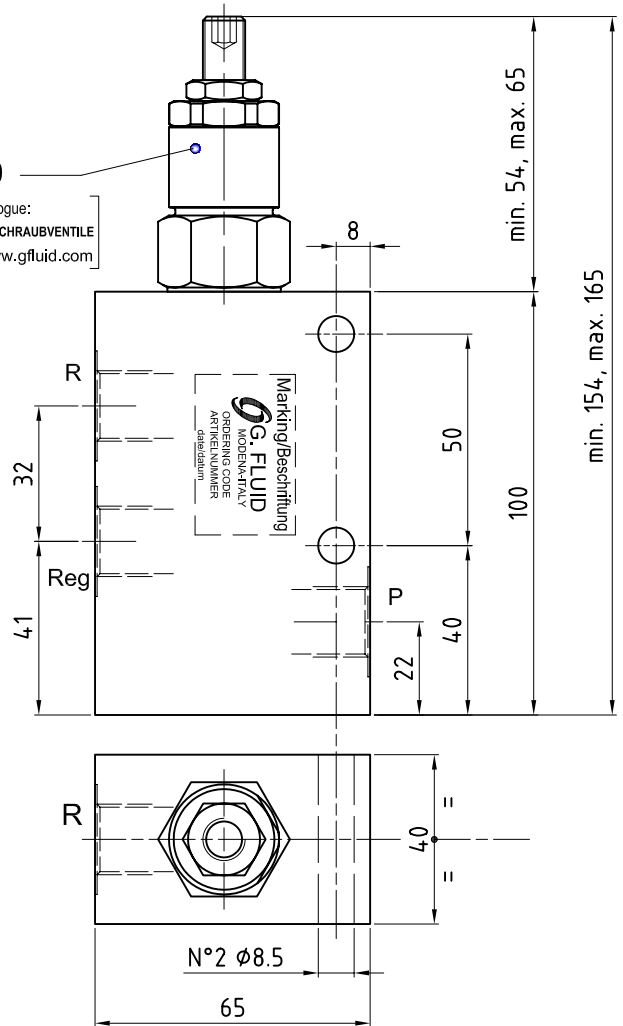

PR110: Adjustment options/Einstellung

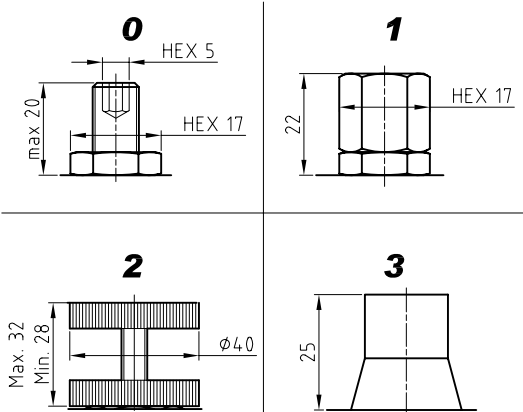

ORDERING CODE - ARTIKELNUMMER

203050 0000

2	Port size Gewinde	1	Adj. range Regelbereich	std setting Standardeinst.	Pressure increase MPa/turn Drucksteigerung MPa je Schraubendrehung	0	Adjustment options Einstellung	0	Material	Weight Gewicht
	G 3/8"	1	1-3 MPa	2 MPa	0.3	0	leakproof socket screw leckdichtfreie Regulierungsschraube	0	AlloyAluminium	1.0 kg
		2	3-10 MPa	5 MPa	0.8	1	closure cap/Verschlusskappe	1	Zincoated Steel/ Verzinkter Stahl	2.5 kg
		3	4-15 MPa	10 MPa	1.5	2	handwheel/Handrad			
						3	protection cap/Schutzkappe			

GRP-150

TECHNICAL DATA TECHNISCHE ANGABEN

Max operating pressure Maximaler Betriebsdruck	25 MPa 3556 psi
Max flow Volumenstrom	120 l/min 31.7 gpm
Max regulated pressure Max. Geregelter Druck	21 MPa 2987 psi
Temperature range Betriebstemperatur	-20°/80°C
Filteraction Filtergrad	15μ

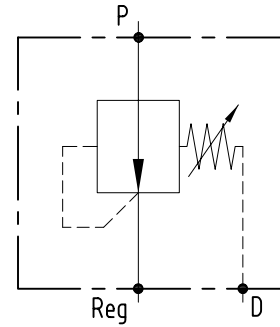

Diagram/Diagramm

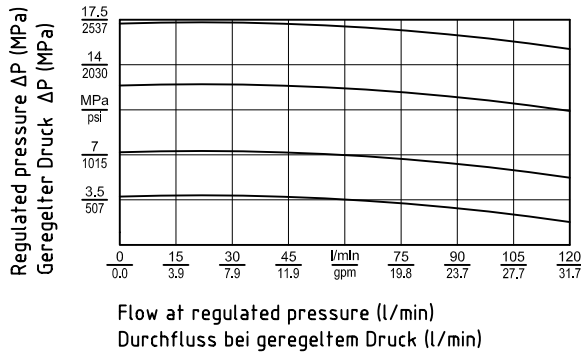

GVRP-150

Katalog / Catalogue:
CARTRIDGE VALVE / EINSCHRAUBVENTILE
web site / Website: www.gfluid.com

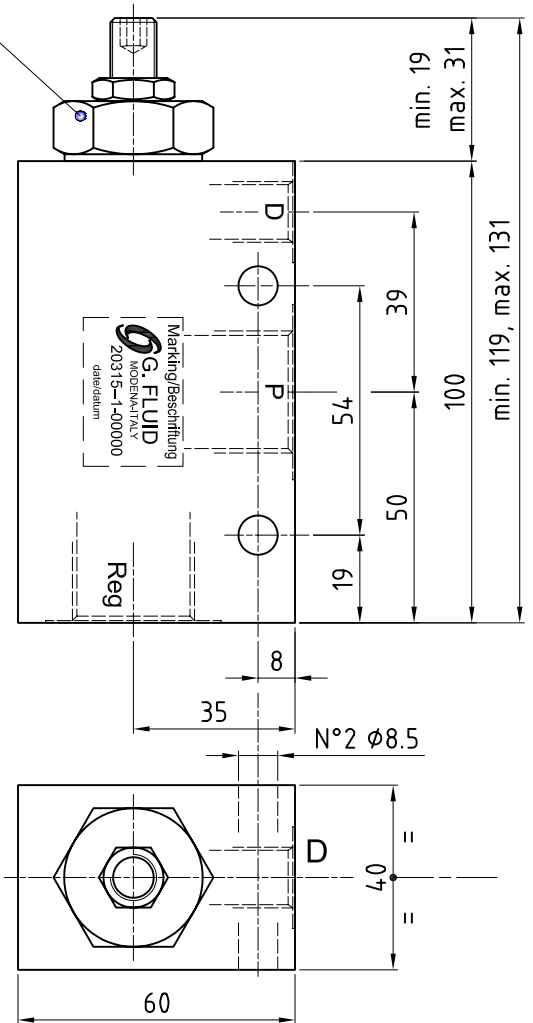

GVRP-150: Adjustment options/Einstellung

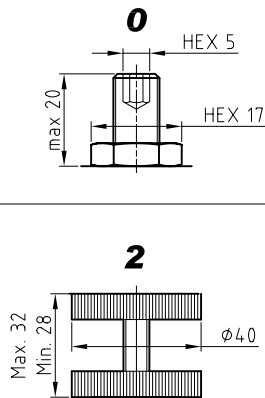

ORDERING INSTRUCTIONS - BESTELLANLEITUNG

20315

0000

03 04	Port size/Gewinde	P, REG	D	1	Spring Feder	standard setting Standardkalibrierung	0 2	Adjustment options Einstellung	0	Material Material	Weigh Gewicht
	G 1/2 G 3/4	G 1/4	2-21 MPa		10 MPa	leakproof socket screw leckölfreie Regulierungsschraube handwheel/Handrad		Alloy Aluminium		0.9 kg	

TECHNICAL DATA
TECHNISCHE ANGABEN

Temperature range Betriebstemperatur	-20°/80°C
Filtration Filtergrad	40µ
Material Material	Zincoated Steel Verzinkter Stahl

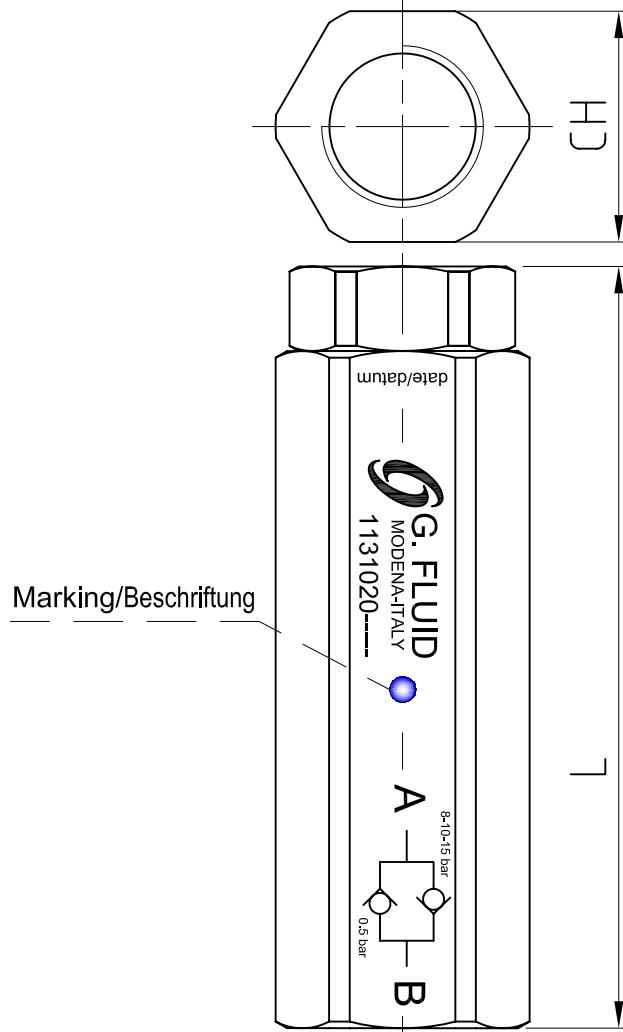
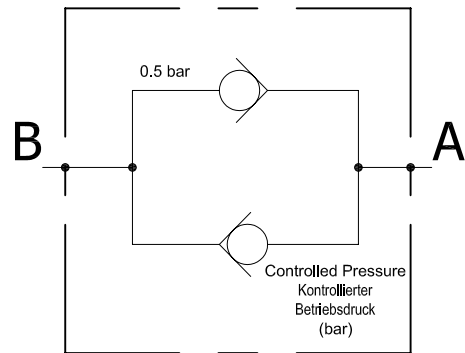
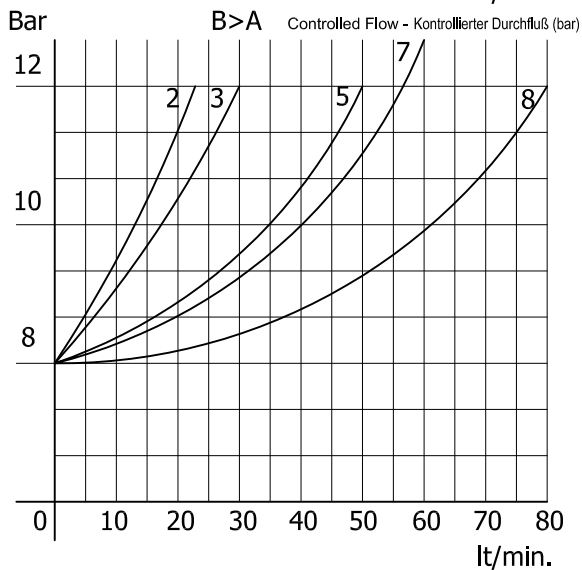
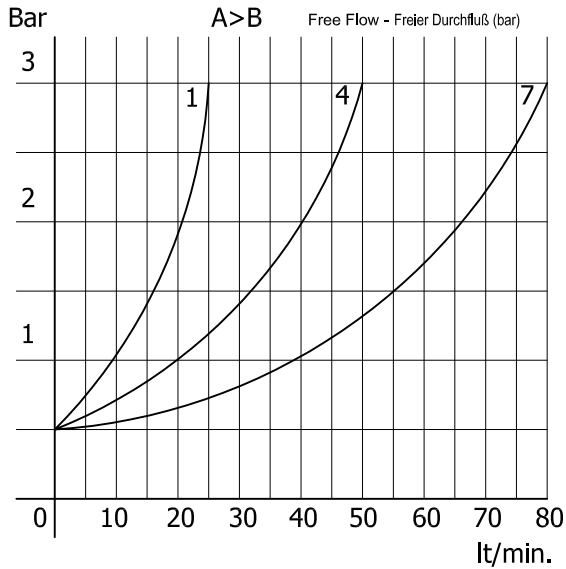
ORDERING INSTRUCTIONS - BESTELLEANLEITUNG

Description Bezeichnung	Code Art.-Nr.	Port size - Gewinde A-B	Max operating pressure Maximaler Betriebsdruck (bar)	Max flow Volumenstrom (lt/min)	CH	L (mm)	Free Pressure Freier Betriebsdruck (A>B bar)	Controlled Pressure Kontrollierter Betriebsdruck (B>A bar)	Weight Gewicht (kg)	Chart Nr. Abbildung Nr.
GUD-38-08	113102021080	G 3/8"	400	25	ES. 30	99	0.5	8	0.48	1
GUD-38-10	113102021100	G 3/8"	400	25	ES. 30	99	0.5	10	0.48	2
GUD-38-15	113102021150	G 3/8"	400	25	ES. 30	99	0.5	15	0.48	3
GUD-12-08	113102031080	G 1/2"	350	50	ES. 36	130	0.5	8	0.88	4
GUD-12-10	113102031100	G 1/2"	350	50	ES. 36	130	0.5	10	0.88	5
GUD-12-15	113102031150	G 1/2"	350	50	ES. 36	130	0.5	15	0.88	6
GUD-34-08	113102041080	G 3/4"	310	80	ES. 46	155	0.5	8	1.71	7
GUD-34-10	113102041100	G 3/4"	310	80	ES. 46	155	0.5	10	1.71	8

**TECHNICAL DATA
 TECHNISCHE ANGABEN**

Max operating pressure Maximaler Betriebsdruck	35 MPa 5076 psi
Max flow Volumenstrom	50 l/min 13.2 gpm
Temperature range Betriebstemperatur	-20°/80°C
Filtration Filtergrad	40μ
Weight Gewicht	0.3 kg (Zincoated Steel Verzinkter Stahl)

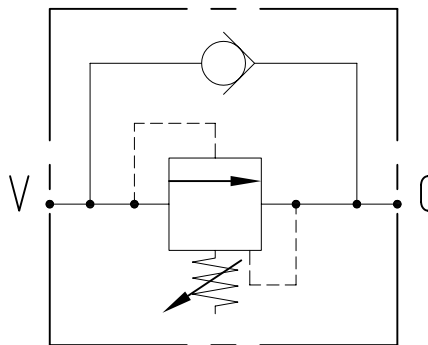
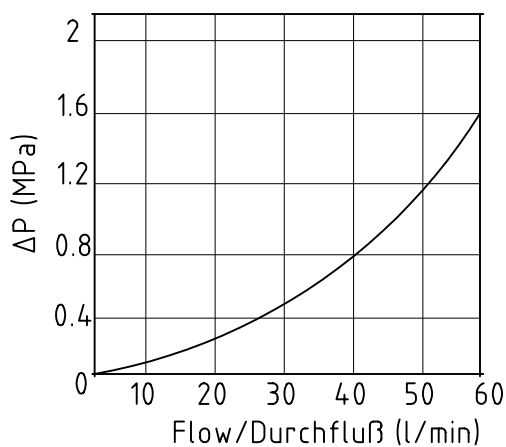
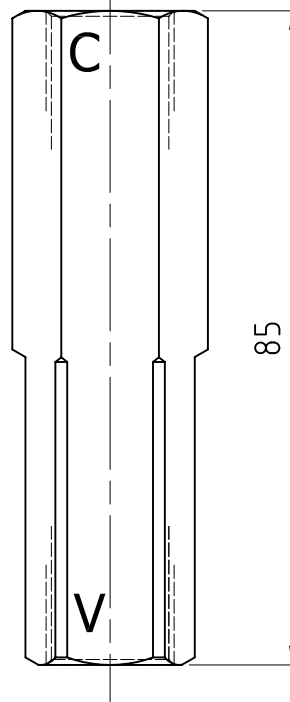
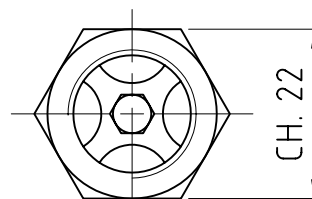
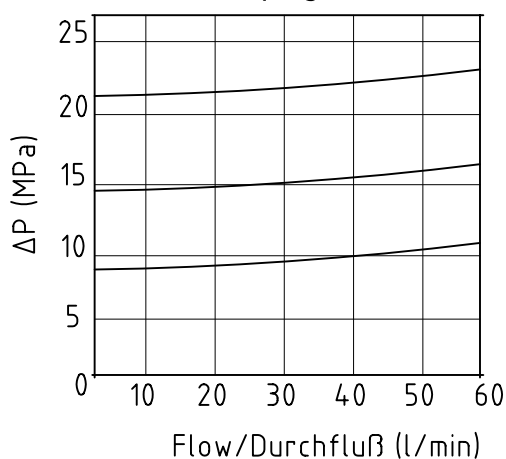
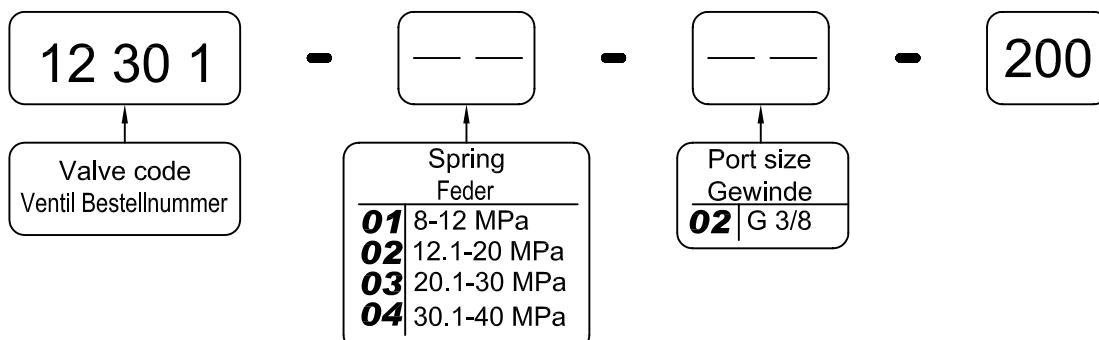
**Diagram/Diagramm
 C→V**

V→C

ORDERING INSTRUCTIONS - BESTELLANLEITUNG

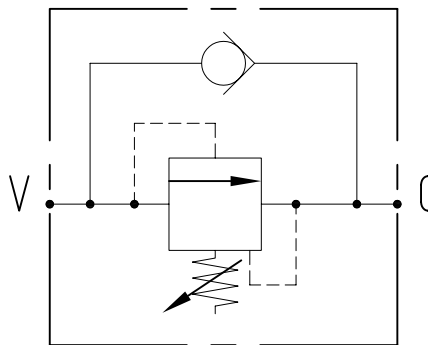
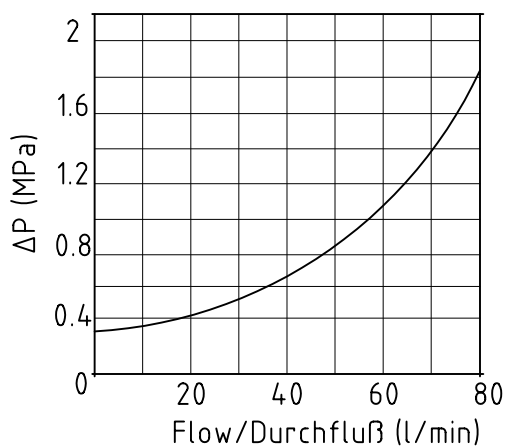
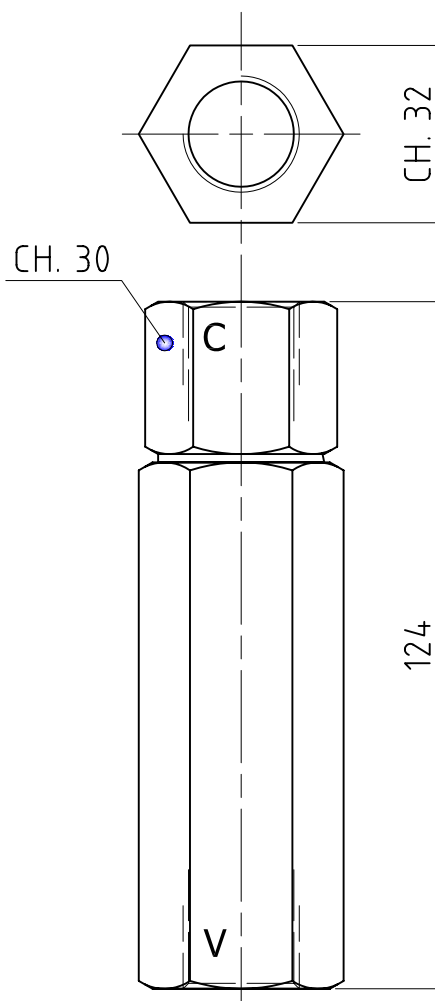
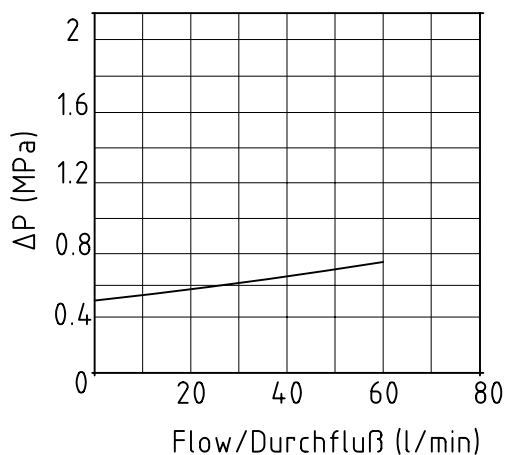
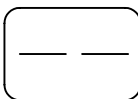
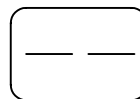
**TECHNICAL DATA
TECHNISCHE ANGABEN**

Max operating pressure Maximaler Betriebsdruck	35 MPa 5076 psi
Max flow Volumenstrom	80 l/min 21.1 gpm
Temperature range Betriebstemperatur	-20°/80°C
Filtration Filtergrad	40µ
Weight Gewicht	0.6 kg (Zincoated Steel Verzinkter Stahl)

**Diagram/Diagramm
C→V**

V→C

ORDERING INSTRUCTIONS - BESTELLANLEITUNG
12 30 2
-

-

-
200

 Spring
Feder

02 | 2.5-7 MPa

 Port size
Gewinde

03 | G 1/2

**TECHNICAL DATA
TECHNISCHE ANGABEN**

Max operating pressure Maximaler Betriebsdruck	35 MPa 5076 psi
Max flow Volumenstrom	30 l/min 7.9 gpm
Temperature range Betriebstemperatur	-20°/80°C
Filtration Filtergrad	40µ
Weight Gewicht	0.8 kg (Alloy/Aluminium) 1.8 kg (Zinc. Steel/Verzink. Stahl)

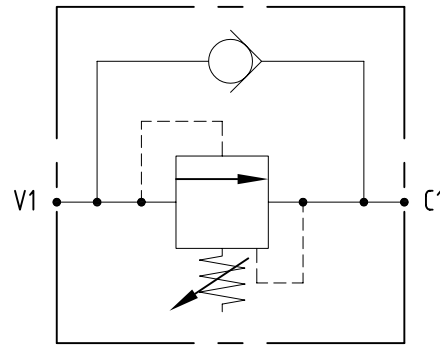
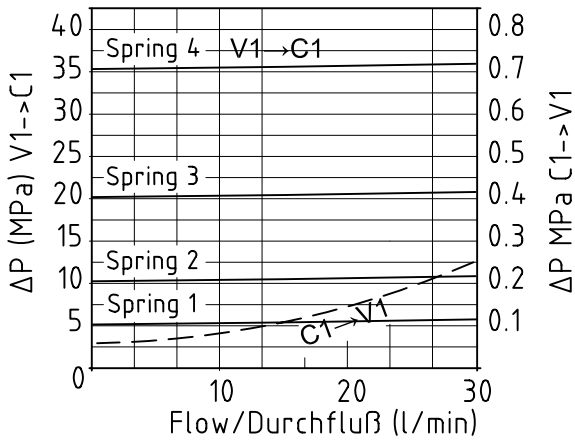
Diagram/Diagramm

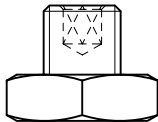
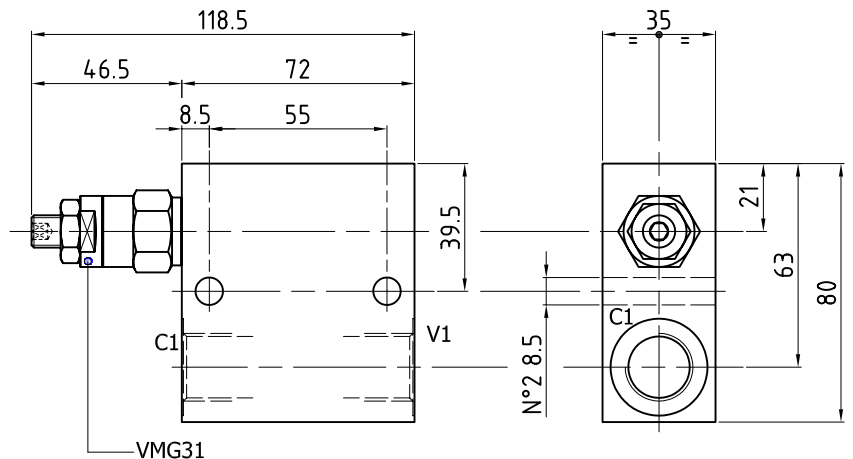
Adjustment options/Einstellung

 leakproof socket screw
leckölfreie Regulierungsschraube

 handknob and
locknut
Handrad und Mutter

 [Seite / Page Katalog / Catalogue
P.01.07-1 GFCC007-11-10]

ORDERING INSTRUCTIONS - BESTELLANLEITUNG
20 63 01

 - [] - [] - [] - [] - [] - [] - [] - [] - **00**
**Adjustment options
Einstellung**

- | | |
|----------|--|
| 0 | leakproof socket screw
leckölfreie Regulierungsschraube |
| 1 | handknob and locknut
Handrad und Mutter |

**Port size
Gewinde**
2 | G 1/2

Spring Feder	standard setting
1	1-6 MPa (6 MPa)
2	5-21 MPa (20 MPa)
3	10-35 MPa (35 MPa)

**Material
Material**

- | | |
|----------|--------------------------------------|
| 0 | Alloy/Aluminium |
| 1 | Zincoated Steel/
Verzinkter Stahl |

GSQ-31I-2

TECHNICAL DATA TECHNISCHE ANGABEN

Max operating pressure Maximaler Betriebsdruck	35 MPa 5076 psi
Max flow Volumenstrom	30 l/min 7.9 gpm
Temperature range Betriebstemperatur	-20°/80°C
Filtration Filtergrad	40µ
Weight Gewicht	0.8 kg (Alloy/Aluminium) 1.8 kg (Zinc. Steel/Verzink. Stahl)

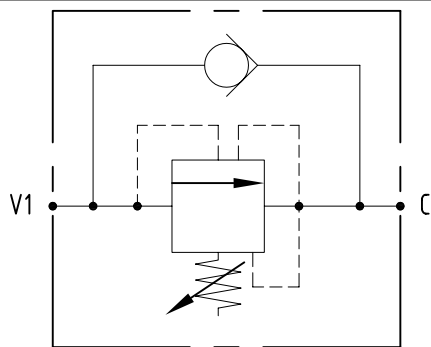

Diagram/Diagramm

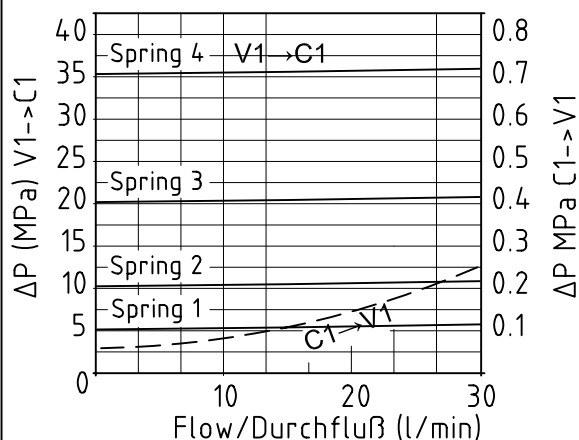

Adjustment options/Einstellung

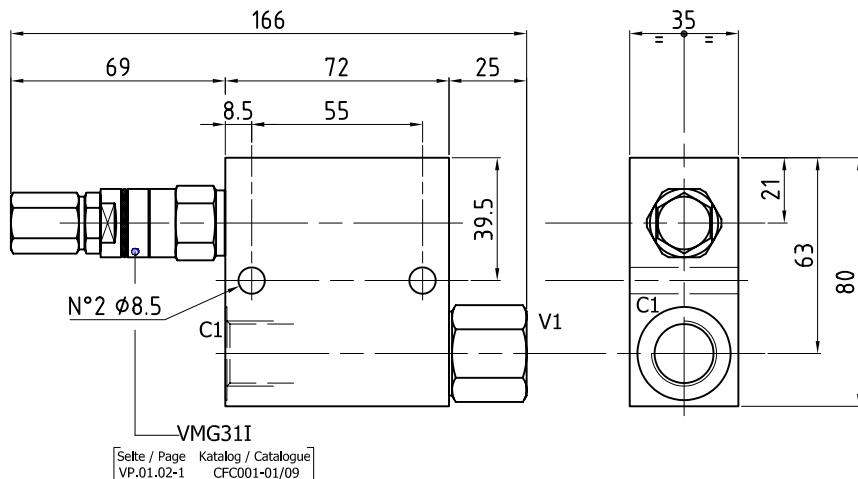
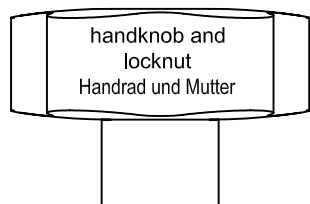
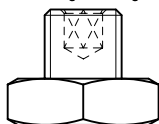
 leakproof socket screw
 leckölfreie Regulierungsschraube

 [Seite / Page Katalog / Catalogue
 VP.01.02-1 CFC001-01/09]

ORDERING INSTRUCTIONS - BESTELLANLEITUNG

20 63 02

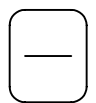

-



-

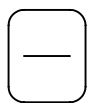

-

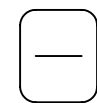

-

00

Adjustment options Einstellung

- | | |
|----------|--|
| 0 | leakproof socket screw
leckölfreie Regulierungsschraube |
| 1 | handknob and locknut
Handrad und Mutter |

Port size Gewinde

- | | |
|----------|-------|
| 2 | G 1/2 |
|----------|-------|

Spring standard setting Feder

- | | |
|----------|--------------------|
| 1 | 1-6 MPa (6 MPa) |
| 2 | 5-21 MPa (20 MPa) |
| 3 | 10-35 MPa (35 MPa) |

Material Material

- | | |
|----------|--------------------------------------|
| 0 | Alloy/Aluminium |
| 1 | Zincoated Steel/
Verzinkter Stahl |

TECHNICAL DATA
TECHNISCHE ANGABEN

Max operating pressure Maximaler Betriebsdruck	25 MPa/3556 psi (Alloy/Alumin.) 35 MPa/5076 psi (Zincoated Steel/Verzink. Stahl)
Max flow Volumenstrom	80 l/min 21.1 gpm
Temperature range Betriebstemperatur	-20°/80°C
Filtration Filtergrad	40µ

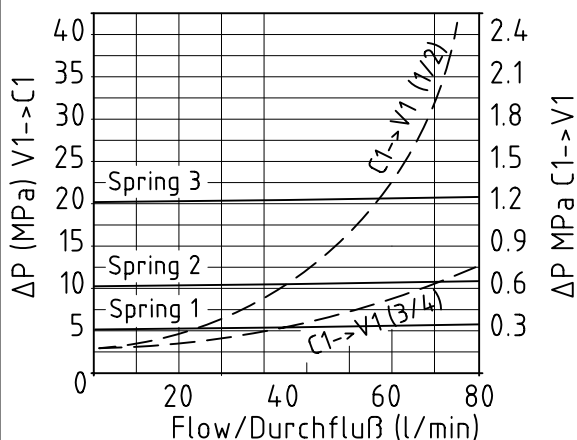
Diagram/Diagramm

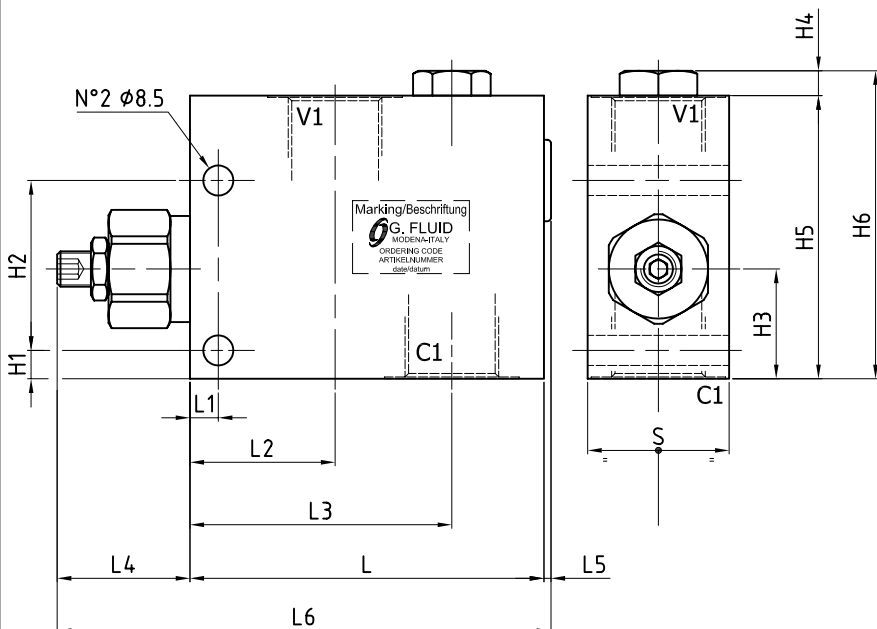
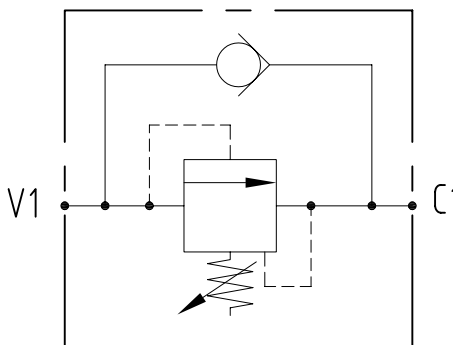
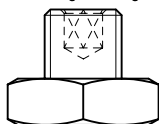
Adjustment options/Einstellung

 leakproof socket screw
 leckölfreie Regulierungsschraube

V1, C1	L	L1	L2	L3	L4	L5	L6	H1	H2	H3	H4	H5	H6	S	Weight/Gewicht	
															Alloy/Alumin.	Zinc. Steel/Verzink. Stahl
1/2"G	100	8	41	67	40	2	142	8	48	32	10	69	79	35	0.7	1.9
3/4"G	100	8	41	74	38	2	140	8	48	31	7	80	87	40	1.0	2.5

ORDERING CODE - ARTIKELNUMMER
206811 00

0	Adjustment options Einstellung leakproof socket screw leckölfreie Regulierungsschraube	2	Port size/Gewinde V1, C1 G 1/2"	1	Adj. range Regelbereich 1.5-5 MPa	std setting Standardeinst. 5 MPa	Pressure increase MPa/turn Drucksteigerung MPa je Schraubendrehung 0.8	0	Material Material Alloy/Aluminium	
3	G 3/4"	2	4-10 MPa	10 MPa	1.6	1				Zincoated Steel
3	7-21 MPa	20 MPa	4.5	1	Verzinkter Stahl					

TECHNICAL DATA
TECHNISCHE ANGABEN

Max operating pressure Maximaler Betriebsdruck	25 MPa/3556 psi (Alloy/Alumin.) 35 MPa/5076 psi (Zincoated Steel/Verzink. Stahl)
Max flow Volumenstrom	80 l/min 21.1 gpm
Temperature range Betriebstemperatur	-20°/80°C
Filtration Filtergrad	40µ

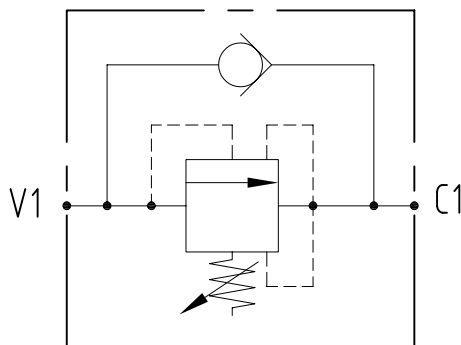
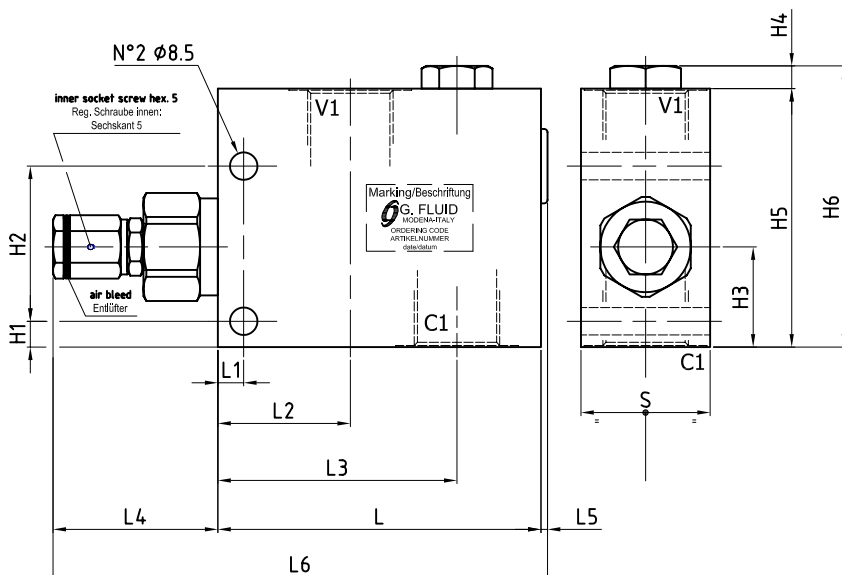
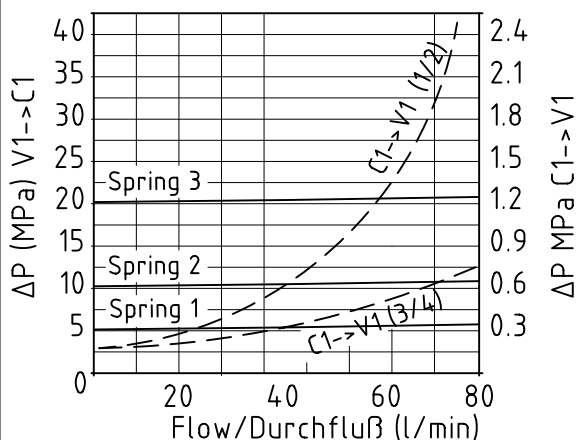

Diagram/Diagramm

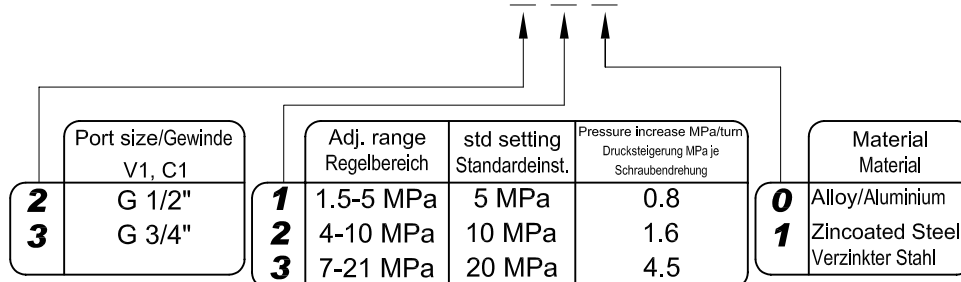
V1, C1	L	L1	L2	L3	L4	L5	L6	H1	H2	H3	H4	H5	H6	S	Weight/Gewicht	
															Alloy/Alumin.	Zinc, Steel/Verzink. Stahl
1/2"G	100	8	41	67	51	2	153	8	48	32	10	69	79	35	0.7	1.9
3/4"G	100	8	41	74	51	2	153	8	48	31	7	80	87	40	1.0	2.5

ORDERING CODE - ARTIKELNUMMER
2068120 00

TECHNICAL DATA
TECHNISCHE ANGABEN

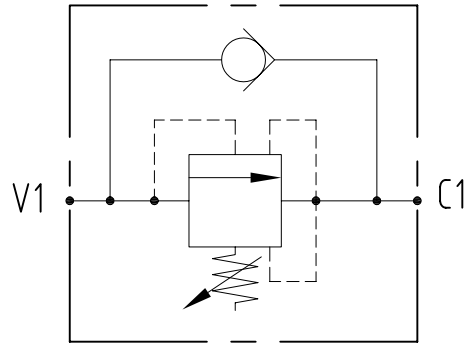
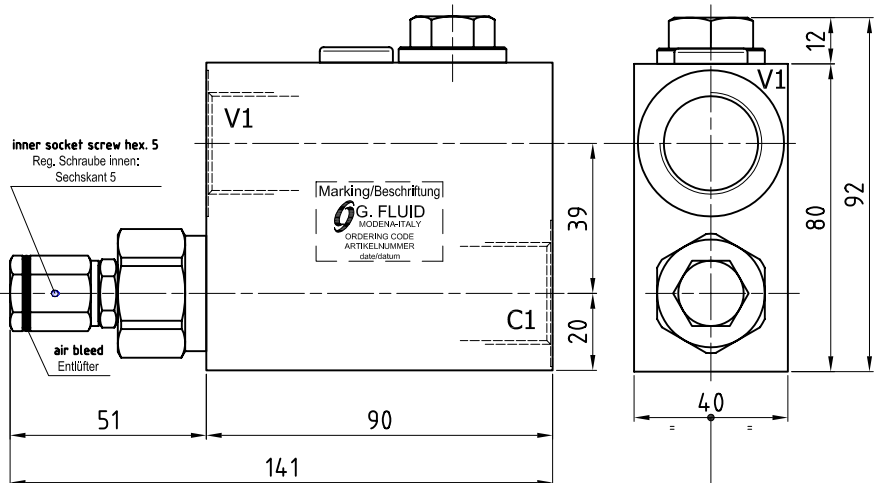
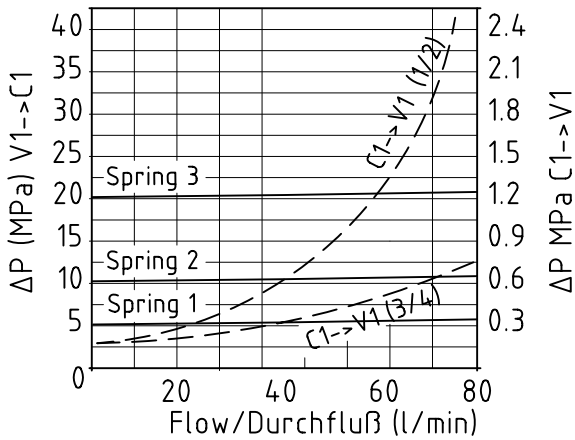
Max operating pressure Maximaler Betriebsdruck	25 MPa/3556 psi (Alloy/Alumin.) 35 MPa/5076 psi (Zincoated Steel/Verzink. Stahl)
Max flow Volumenstrom	80 l/min 21.1 gpm
Temperature range Betriebstemperatur	-20°/80°C
Filtration Filtergrad	40µ



Diagram/Diagramm

ORDERING CODE - ARTIKELNUMMER
2068220 00

3	Port size/Gewinde V1, C1	1	Adj. range Regelbereich	5	0.8	0	Material Material	Weigth Gewicht				
	G 3/4"		std setting Standardeinst.						5 MPa	0.8	Alloy/Aluminium	1.1 kg
	2		1.5-5 MPa						10 MPa	1.6	Zincoated Steel	2.4 kg
		3	7-21 MPa	20 MPa	4.5		Verzinkter Stahl					

GSQ-150-2-3

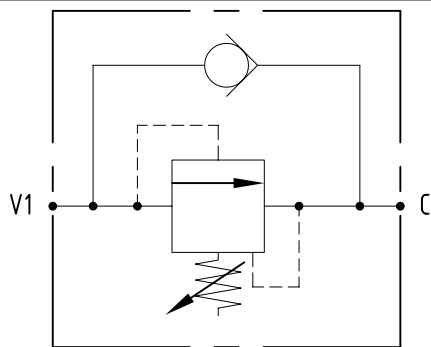
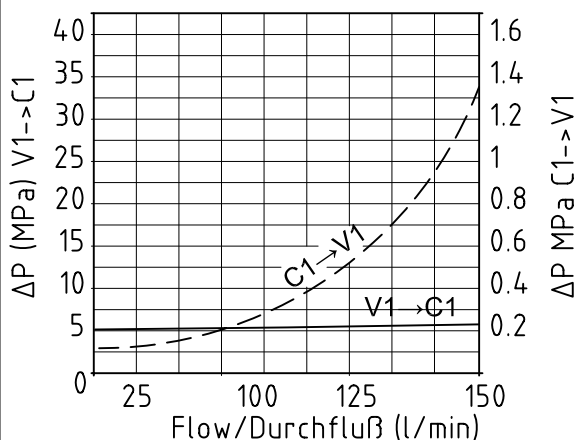
TECHNICAL DATA
TECHNISCHE ANGABEN

Max operating pressure Maximaler Betriebsdruck	21 MPa-2987 psi (Alloy/Aluminium) 35 MPa-5076 psi (Zincoated Steel/Verzink. Stahl)
Max flow Volumenstrom	150 l/min 39.6 gpm
Temperature range Betriebstemperatur	-20°/80°C
Filtration Filtergrad	40µ
Weight Gewicht	1.07 kg (Alloy/Aluminium) 2.6 kg (Zinc. Steel/Verzink. Stahl)

Diagram/Diagramm

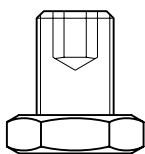
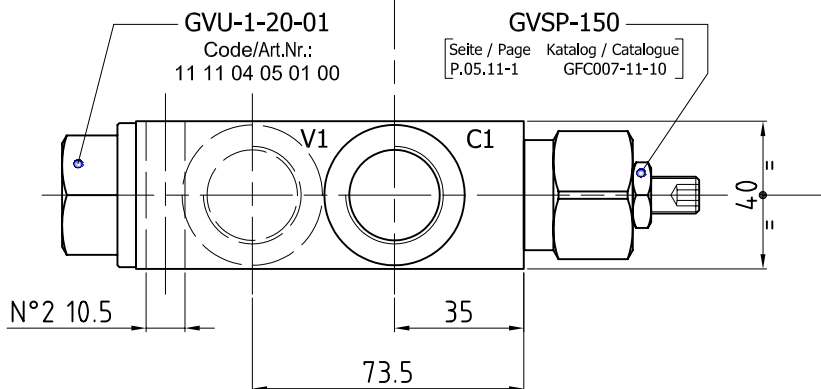
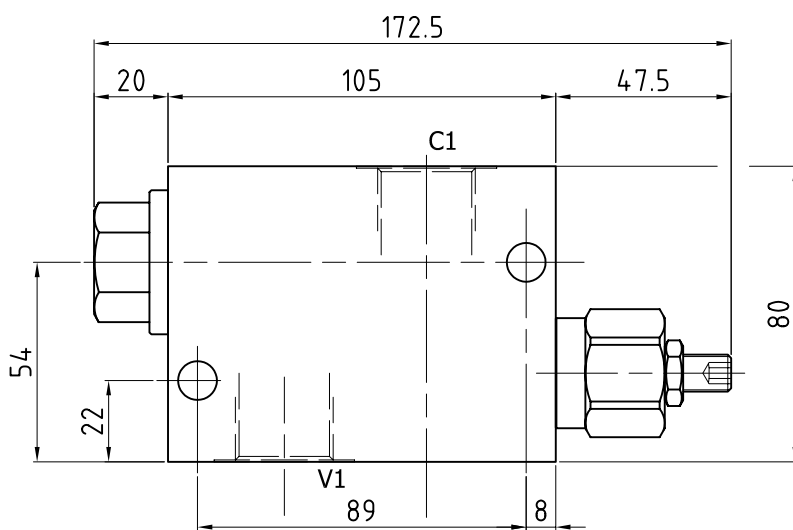
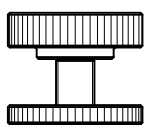
Adjustment options/Einstellung

 leakproof socket screw
 leckölfreie Regulierungsschraube

 Handwheel
 Handrad

ORDERING INSTRUCTIONS - BESTELLANLEITUNG
20 61 51

01
Adjustment options
Einstellung

- | | |
|----------|--|
| 0 | leakproof socket screw
leckölfreie Regulierungsschraube |
| 1 | handknob and locknut
Handrad und Mutter |

Port size
Gewinde

- | | |
|----------|-------|
| 2 | G 1/2 |
| 3 | G 3/4 |

Spring
Feder

- | | |
|----------|-------------------|
| 1 | 1-10 MPa (8 MPa) |
| 2 | 5-45 MPa (25 MPa) |

Material
Material

- | | |
|----------|--------------------------------------|
| 0 | Alloy/Aluminium |
| 1 | Zincoated Steel/
Verzinkter Stahl |

GSQ-150I-2-3

TECHNICAL DATA
TECHNISCHE ANGABEN

Max operating pressure Maximaler Betriebsdruck	21 MPa-2987 psi (Alloy/Aluminium) 35 MPa-5076 psi (Zincoated Steel/Verzink. Stahl)
Max flow Volumenstrom	150 l/min 39.6 gpm
Temperature range Betriebstemperatur	-20°/80°C
Filtration Filtergrad	40µ
Weight Gewicht	1.07 kg (Alloy/Aluminium) 2.6 kg (Zinc. Steel/Verzink. Stahl)

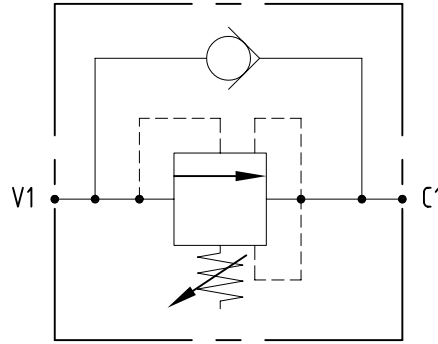
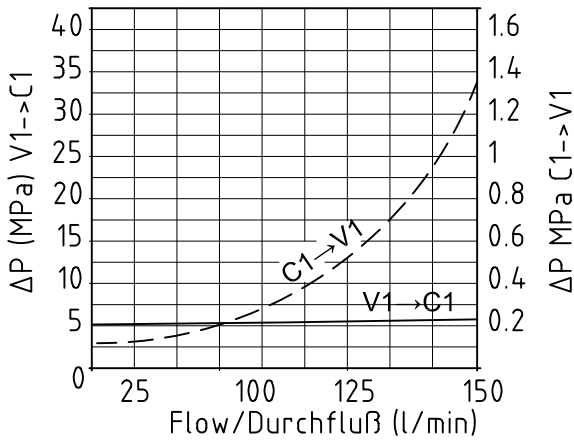
Diagram/Diagramm

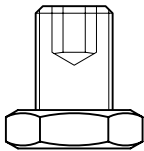
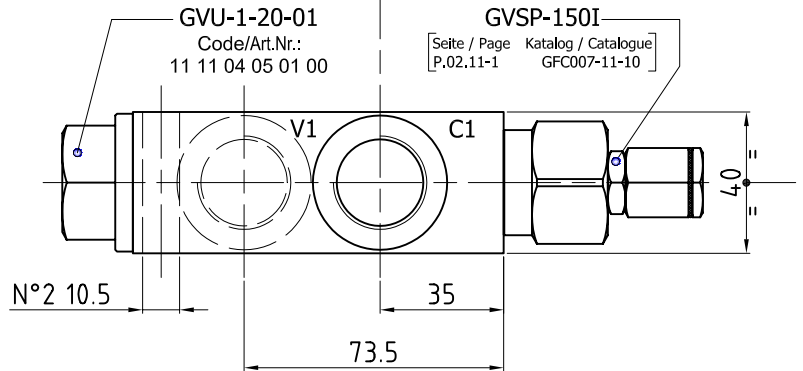
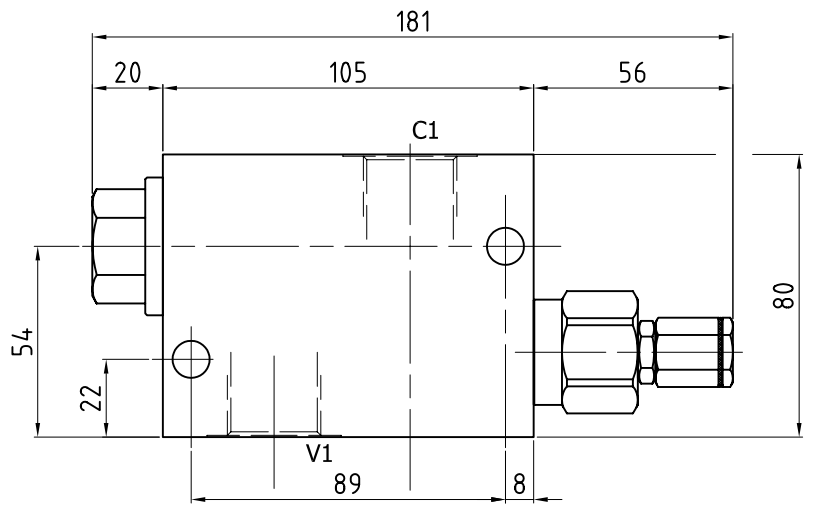
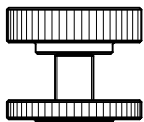
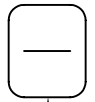
Adjustment options/Einstellung

 leakproof socket screw
 leckölfreie Regulierungsschraube

 Handwheel
 Handrad

ORDERING INSTRUCTIONS - BESTELLANLEITUNG
20 61 52

00
Adjustment options
Einstellung

- | | |
|----------|--|
| 0 | leakproof socket screw
leckölfreie Regulierungsschraube |
| 1 | handknob and locknut
Handrad und Mutter |

Port size
Gewinde

- | | |
|----------|-------|
| 2 | G 1/2 |
| 3 | G 3/4 |

Spring
Feder

- | | |
|----------|-------------------|
| 1 | 1-10 MPa (8 MPa) |
| 2 | 5-45 MPa (25 MPa) |

Material
Material

- | | |
|----------|--------------------------------------|
| 0 | Alloy/Aluminium |
| 1 | Zincoated Steel/
Verzinkter Stahl |

GVS-BP-GSVR-150-SA-SC-34

TECHNICAL DATA TECHNISCHE ANGABEN

Max operating pressure Maximaler Betriebsdruck	35 MPa 5076 psi
Max flow Volumenstrom	150 l/min 39.6 gpm
Temperature range Betriebstemperatur	-20°/80°C
Filtration Filtergrad	40μ
Weight Gewicht	0.8 kg (Alloy/Aluminium) 1.9 kg (Zinc. Steel/Verzink. Stahl)

For use in circuits which require relief protection and a solenoid valve feature for unloading or dumping system flow to tank.

May be used as a two-way directional control with built-in relief protection in any hydraulic system.

Anwendung in Kreisläufen, die Druckbegrenzung und Bypass zum Tank voraussetzen.
Kann als Zwei-Wege Sitzventil mit eingebautem Druckbegrenzungsventil in jedem beliebigen Hydrauliksystem verwendet werden.

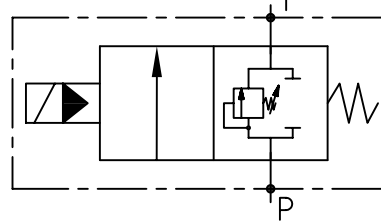
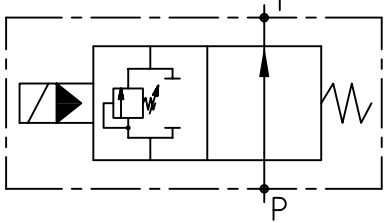
0: N.C.

1: N.O.

PORT SIZE GEWINDE

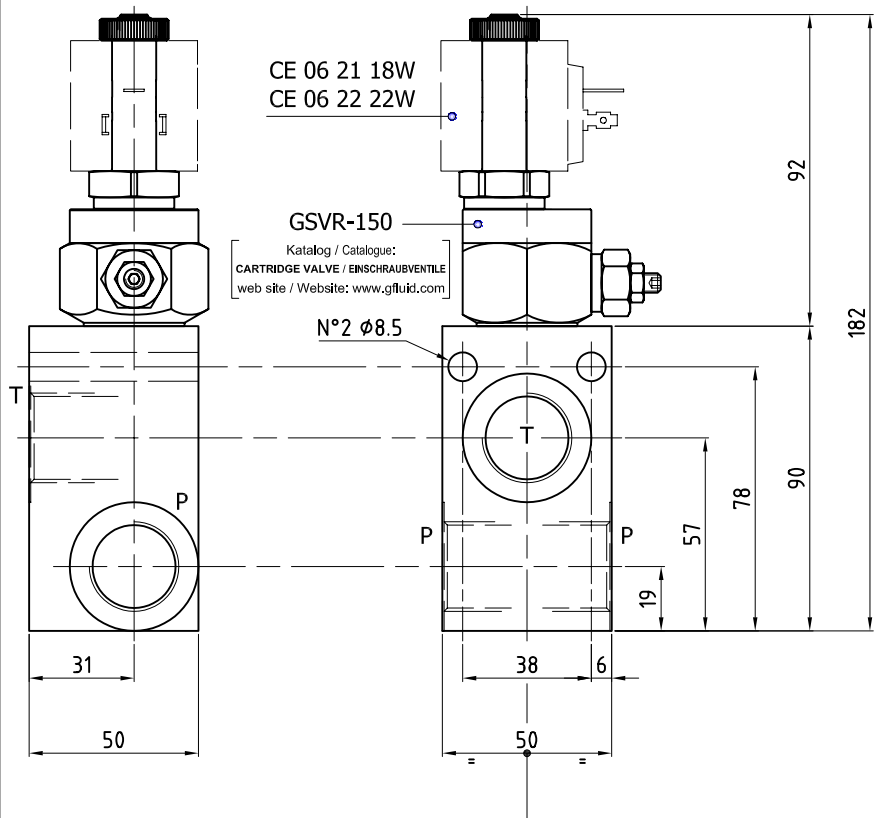
T, P, P	G 3/4"
---------	--------



ORDERING INSTRUCTIONS - BESTELLANLEITUNG

20 75
-

-
03
-

-

-
000

Solenoid operated valve Sitzventil	
0	N.C.
1	N.O.

Spring Feder		Standard setting Standardeinstellung	
0	2.5-25 MPa	10	10 MPa
1	20-46 MPa	35	35 MPa

Material Material	
0	Alloy/Aluminium
1	Zincoated Steel/ Verzinkter Stahl

**TECHNICAL DATA
 TECHNISCHE ANGABEN**

Max operating pressure Maximaler Betriebsdruck	35 MPa 5076 psi
Max flow Volumenstrom	150 l/min 39.6 gpm
Temperature range Betriebstemperatur	-20°/80°C
Filtration Filtergrad	40µ
Weight Gewicht	0.8 kg (Alloy/Aluminium) 1.9 kg (Zinc. Steel/Verzink. Stahl)

For use in circuits which require relief protection and a solenoid valve feature for unloading or dumping system flow to tank.
 May be used as a two-way directional control with built-in relief protection in any hydraulic system.

Anwendung in Kreisläufen, die Druckbegrenzung und Bypass zum Tank voraussetzen.
 Kann als Zwei-Wege Sitzventil mit eingebautem Druckbegrenzungsventil in jedem beliebigen Hydrauliksystem verwendet werden.

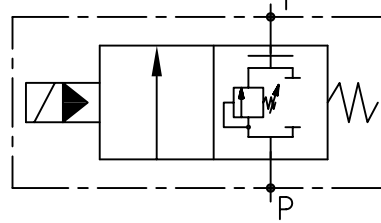
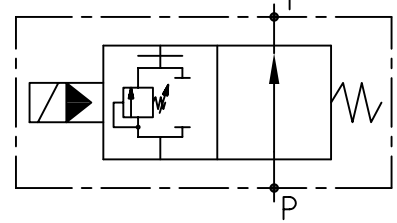
2: N.C. D.T.

3: N.O. D.T.

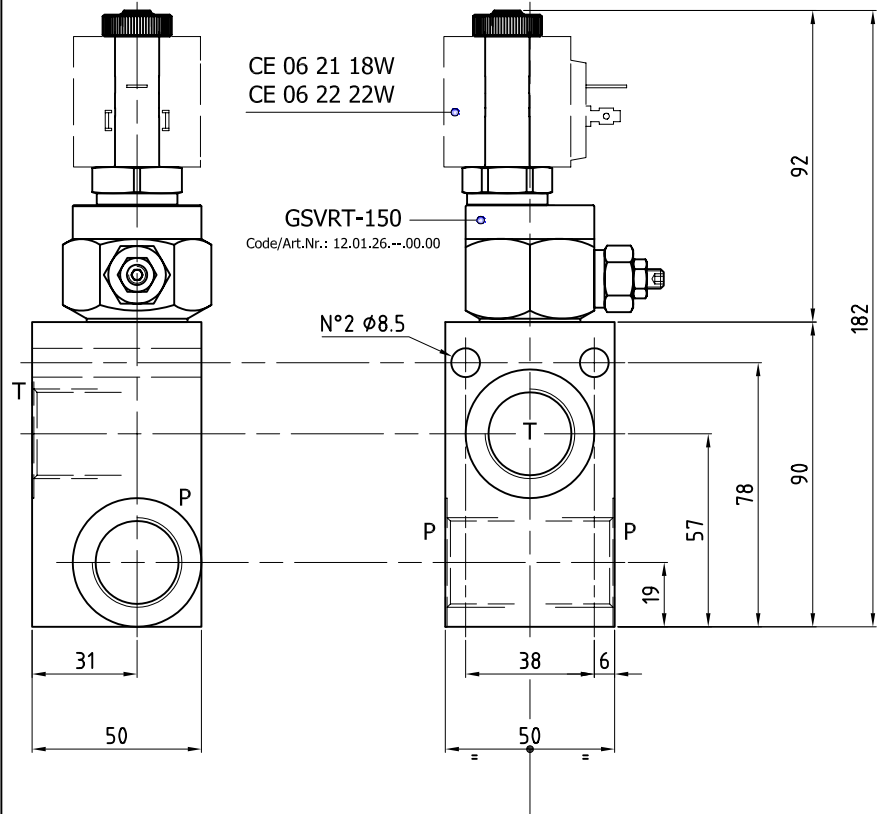
**PORT SIZE
 GEWINDE**

T, P	G 3/4"
------	--------

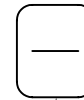
ORDERING INSTRUCTIONS - BESTELLANLEITUNG
20 75
-

-
03
-

-

-
000

Solenoid operated valve Sitzventil	
2	N.C. D.T.
3	N.O. D.T.

Spring Feder		Standard setting Standardeinstellung	
0	2.5-25 MPa	10 MPa	
1	20-46 MPa	35 MPa	

Material Material	
0	Alloy/Aluminium
1	Zincoated Steel/ Verzinkter Stahl

GVS-BP-VMG80-SA-SC

TECHNICAL DATA
TECHNISCHE ANGABEN

Max operating pressure Maximaler Betriebsdruck	35 MPa 5076 psi
Max flow Volumenstrom	80 l/min 21.1 gpm
Temperature range Betriebstemperatur	-20°/80°C
Filtration Filtergrad	40µ
Weight Gewicht	1.4 kg (Alloy/Aluminium) 3.5 kg (Zinc. Steel/Verzink. Stahl)

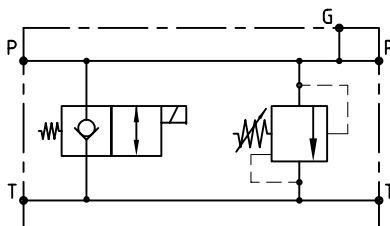
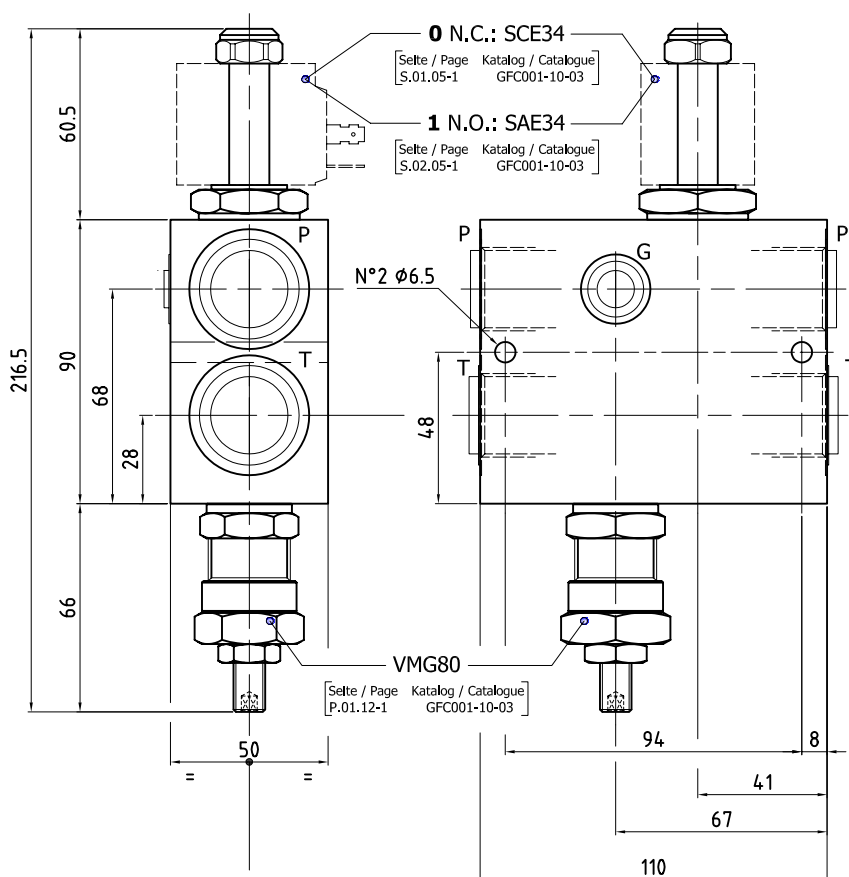
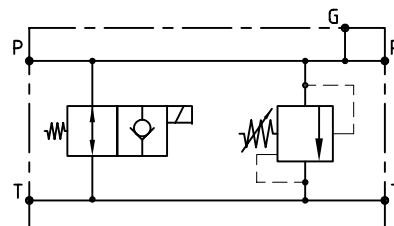
0: N.C.

1: N.O.

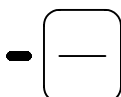
PORT SIZE
GEWINDE

T, P	G 3/4"
G	G 1/4"

ORDERING INSTRUCTIONS - BESTELLANLEITUNG
20 73

03

-

-

00

Solenoid operated valve Sitzventil	
0	N.C.
1	N.O.

Spring Feder		Standard setting Standardeinstellung
1	0.5-5 MPa	5 MPa
2	3.5-10 MPa	10 MPa
3	8-25 MPa	20 MPa

Material Material	
0	Alloy/Aluminium
1	Zincoated Steel/ Verzinkter Stahl

Adjustment options Einstellung	
0	leakproof socket screw leckölfreie Regulierungsschraube
2	handknob and locknut Handrad und Mutter

**TECHNICAL DATA
TECHNISCHE ANGABEN**

Max operating pressure Maximaler Betriebsdruck	25 MPa/3556 psi (Alloy/Alumin.) 35 MPa/5076 psi (Zincoated Steel/Verzink. Stahl)
Max flow Volumenstrom	200 l/min 52.8 gpm
Temperature range Betriebstemperatur	-20°/80°C
Filtration Filtergrad	40µ
Coil Spule	CE 06 62 -- - page/site Z.05.02-2 Katalog/Catalogue GFC005-11-05 web site / Website: www.gfluid.com

0: N.C.

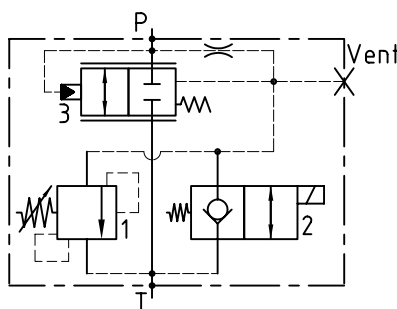

1: N.O.

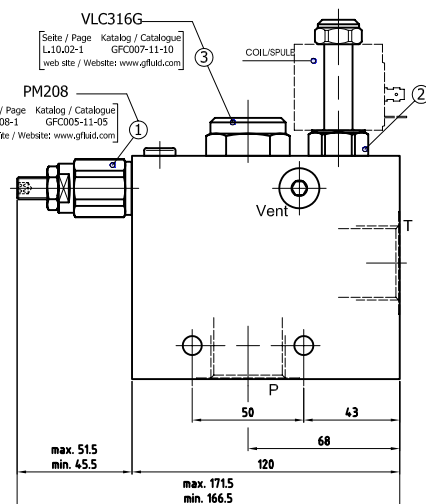
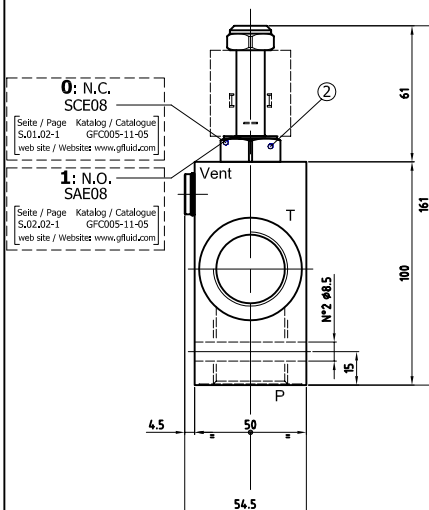
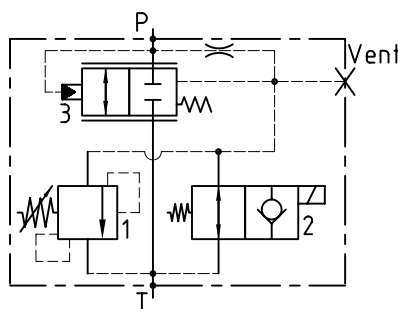

**PORT SIZE
GEWINDE**

Vent	G 1/4"

ORDERING INSTRUCTIONS - BESTELLANLEITUNG

20 86

0	03	0	0	0	0	00
Solenoid operated valve Sitzventil	Port size Gewinde	Spring Feder	Standard setting	Material Material	Adjustment options Einstellung	
0 N.C. 1 N.O.	03 G 3/4 04 G 1	0 1-6 MPa 1 5-20 MPa 2 20-35 MPa	(5 MPa) (18 MPa) (30 MPa)	0 Alloy/Aluminium 1 Zincoated Steel/ Verzinkter Stahl	0 no manual override/ohne Notbetätigung 1 manual override/Notbetätigung 2 leakproof socket screw leckköfrefreie Regulierungsschraube 3 handknob and locknut Handrad und Mutter	

TECHNICAL DATA TECHNISCHE ANGABEN	
Max operating pressure Maximaler Betriebsdruck	25 MPa/3556 psi (Alloy/Alumin.) 35 MPa/5076 psi (Zincoated Steel/Verzink. Stahl)
Max flow Volumenstrom	200 l/min 52.8 gpm
Temperature range Betriebstemperatur	-20°/80°C
Filtration Filtergrad	40µ
Coil Spule	CE 06 62 -- - page/site Z.05.02-2 Katalog/Catalogue GFC005-11-05 web site / Website: www.gfluid.com

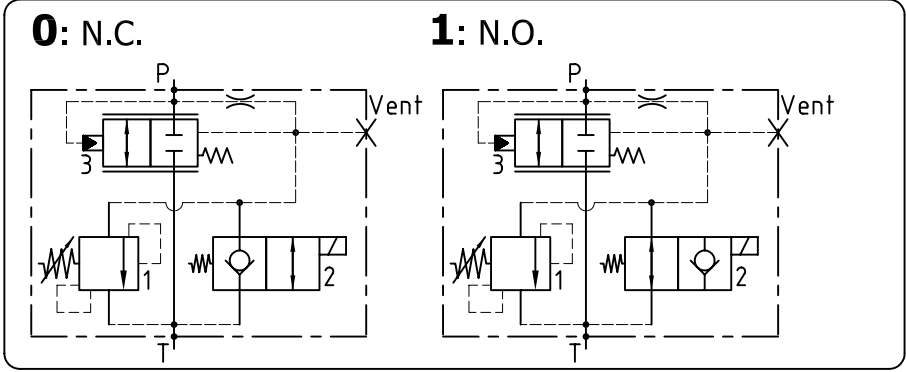

PORT SIZE GEWINDE	
Vent	G 1/4"

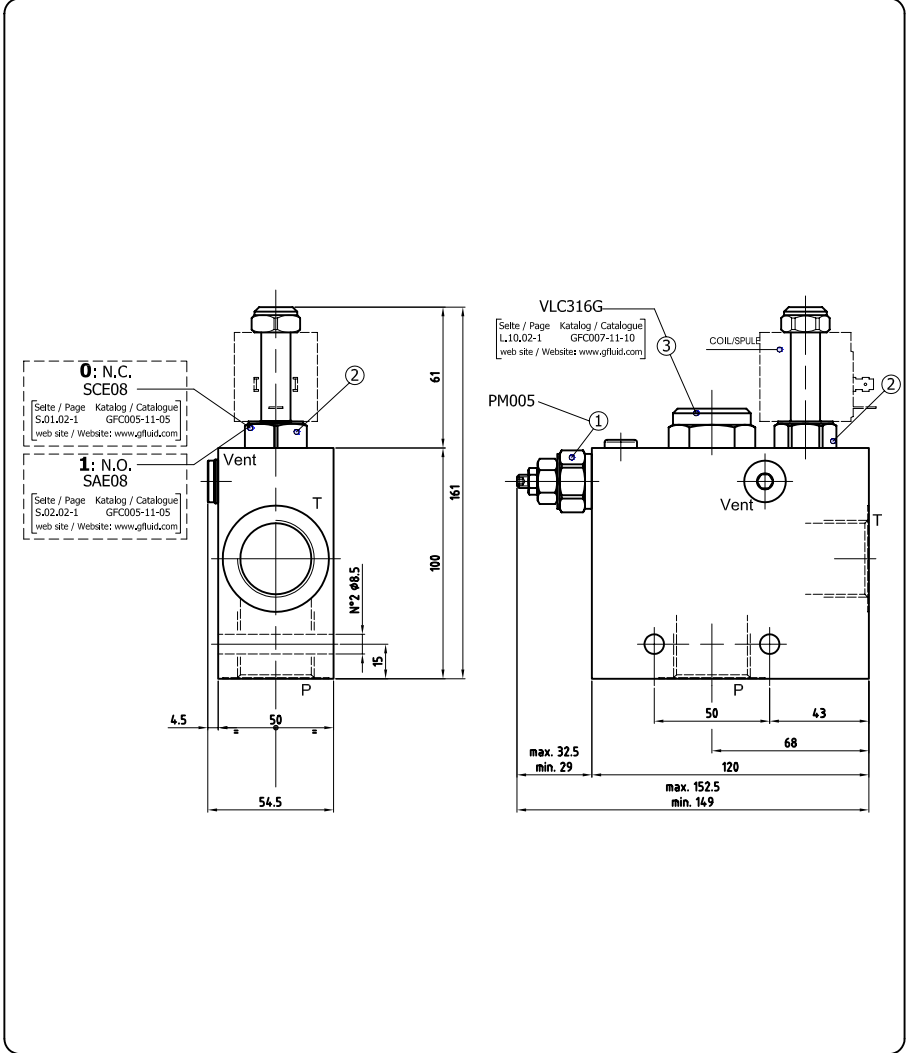

ORDERING INSTRUCTIONS - BESTELLANLEITUNG

20 86 - - - - - - - - 50

Solenoid operated valve Sitzventil	Port size Gewinde	Spring Feder	Standard setting	Material Material	Adjustment options Einstellung
0 N.C. 1 N.O.	03 G 3/4 04 G 1	0 2.5-25 MPa (10 MPa) 1 20-35 MPa (35 MPa)		0 Alloy/Aluminium 1 Zincoated Steel/ Verzinkter Stahl	0 no manual override/ohne Notbetätigung 1 manual override/Notbetätigung 2 leakproof socket screw lecköfrefreie Regulierungsschraube 3 handknob and locknut Handrad und Mutter

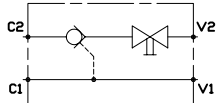
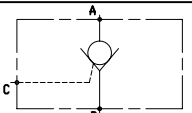
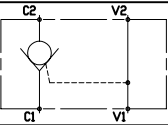
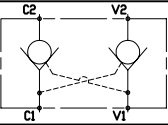
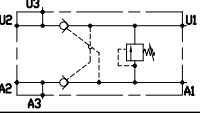
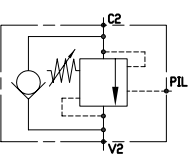
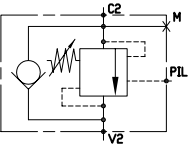
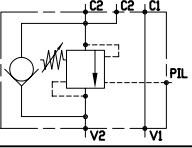
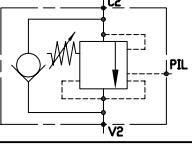
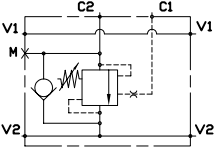
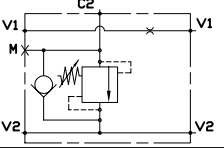
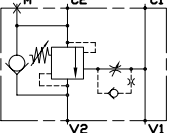
Schema Schema	Description Bezeichnung	max flow max Durchfluß	max pressure max Arbeitsdruck	page Seite
	GVU-SE-RLD GVU-SE-RLS	60 l/min 15.8 gpm	35 MPa 5076 psi	2.001.10 2.001.20
	GULP-_-_-	15-35-55 l/min 3.9-9.2-14.5 gpm	50-70 MPa 7250-10150 psi	2.002.10
	GVU-P-SE-14	20 l/min 15.3 gpm	35 MPa 5076 psi	2.002.50
	GVU-DE GVU-DE-F1	20-50-80 l/min 7.9-13.2-21.1 gpm	35 MPa 5076 psi	2.002.80 2.002.90
	GVU-DE-VS-38-FB	40 l/min 10.6 gpm	35 MPa 5076 psi	2.002.110
	VBG-SE-61 VBG-SE-62 VBG-SE-78 VBG-SE-30 VBG-SE-71	40 l/min - 10.6 gpm 40 l/min - 10.6 gpm 40 l/min - 10.6 gpm 60 l/min - 15.9 gpm 220 l/min - 58.0 gpm	35 MPa 5076 psi	2.003.10 2.003.20 2.003.30 2.003.70 2.003.200
	VBG-SE-63 VBG-SE-64	70 l/min 18.5 gpm	35 MPa 5076 psi	2.003.40 2.003.50
	VBG-SE-30-09	60 l/min 15.9 gpm	35 MPa 5076 psi	2.003.60
	VBG-SE-30I	60 l/min 15.9 gpm	35 MPa 5076 psi	2.003.80
	VBG-SE-F1-30-PLR	60 l/min 15.9 gpm	35 MPa 5076 psi	2.003.90
	VBG-SE-F1-30-38-PLR	60 l/min 15.9 gpm	35 MPa 5076 psi	2.003.100
	VBG-SE-30-PLR VBG-SE-33-PLR VBG-SE-F1-33-PLR	60 l/min - 15.9 gpm 150 l/min - 39.6 gpm 150 l/min - 39.6 gpm	35 MPa 5076 psi	2.003.110 2.003.120 2.003.140

Schema Schema	Description Bezeichnung	max flow max Durchfluß	max pressure max Arbeitsdruck	page Seite
	VBG-SE-33-I-PLR VBG-SE-F1-33-I-PLR VBG-SE-F1-33-43-I-PLR	35 MPa 5076 psi	35 MPa 5076 psi	2.003.130 2.003.150 2.003.160
	VBG-SE-24	140 l/min 36.9 gpm	35 MPa 5076 psi	2.003.170
	VBG-SE-150 VBG-SE-150-39	150 l/min 39.6 gpm	35 MPa 5076 psi	2.003.180 2.003.190
	VBG-SE-72	220 l/min 58.0 gpm	35 MPa 5076 psi	2.003.210
	VBG-SE-100	100 l/min 26.4 gpm	35 MPa 5076 psi	2.003.500
	VBG-SE-100-BP	100 l/min 26.4 gpm	35 MPa 5076 psi	2.003.510
	GVS-VMG31I-PB010-38-020-THM	40 l/min 10.6 gpm	20 MPa 2844 psi	2.003.700
	VBG-DE-78 VBG-DE-30 VBG-DE-F-30 VBG-DE-81 VBG-DE-24 VBG-DE-91 VBG-DE-92	40 l/min - 10.6 gpm 60 l/min - 15.9 gpm 60 l/min - 15.9 gpm 70 l/min - 18.5 gpm 140 l/min - 36.9 gpm 220 l/min - 58.0 gpm 220 l/min - 58.0 gpm	35 MPa 5076 psi	2.004.30 2.004.80 2.004.90 2.004.120 2.004.180 2.004.190 2.004.200
	VBG-DE-VM-30	60 l/min 15.9 gpm	35 MPa 5076 psi	2.004.100
	VBG-DE-F-M-30	60 l/min 15.9 gpm	35 MPa 5076 psi	2.004.110

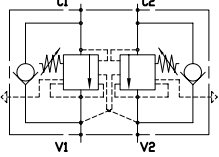
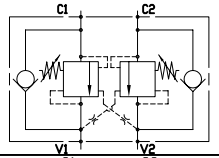
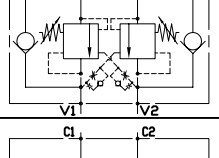
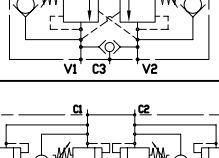
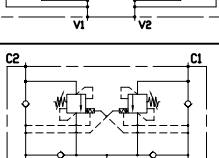
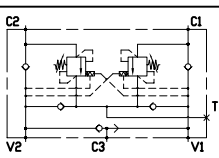
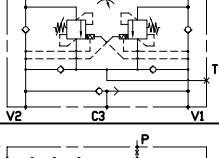
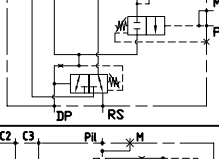
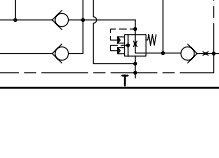
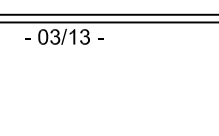
Schema Schema	Description Bezeichnung	max flow max Durchfluß	max pressure max Arbeitsdruck	page Seite
	VBG-DE-30-I VBG-DE-F-30-I	60 l/min 15.9 gpm	35 MPa 5076 psi	2.004.130 2.004.140
	VBG-DE-33	150 l/min 39.6 gpm	35 MPa 5076 psi	2.004.150
	VBG-DE-33-PLR VBG-DE-F1-33-PLR	150 l/min 39.6 gpm	35 MPa 5076 psi	2.004.160 2.004.170
	VBG-DE-SL-30	60 l/min 15.9 gpm	35 MPa 5076 psi	2.004.300
	VBG-DE-2VM-25	25 l/min 6.6 gpm	35 MPa 5076 psi	2.004.400
	GVA-50-52	40 l/min 10.6 gpm	35 MPa 5076 psi	2.010.10
	GVA-120-53-S GVA-250-53-	120 l/min - 31.7 gpm 200 l/min - 53.0 gpm	35 MPa 5076 psi	2.010.17 2.010.27
	GVA-120-53-ST-S GVA-120-53-ST-10-S	120 l/min 31.7 gpm	35 MPa 5076 psi	2.010.20 2.010.21
	GLM-3PS-20-12-S	20 l/min 5.3 gpm	35 MPa 5076 psi	2.050.10
	GLM-60-12-S	60 l/min 15.9 gpm	35 MPa 5076 psi	2.050.20

TECHNICAL DATA
TECHNISCHE ANGABEN

Max operating pressure Maximaler Betriebsdruck	35 MPa 5076 psi
Max flow Volumenstrom	see table/siehe Tabelle
Temperature range Betriebstemperatur	-20°/80°C
Filtration Filtergrad	40µ
Material Material	Zincoated Steel Verzinkter Stahl

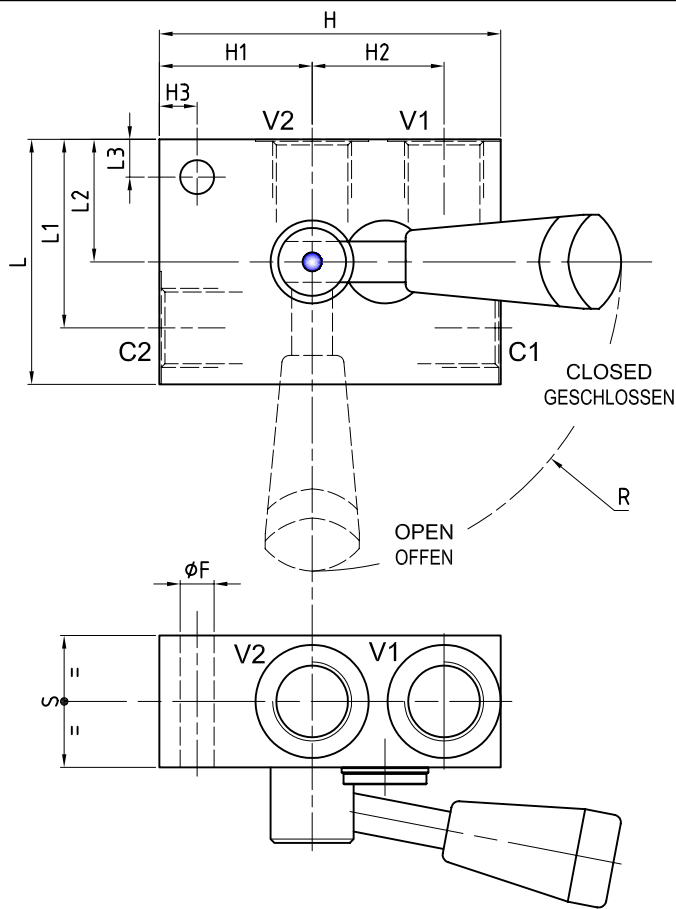
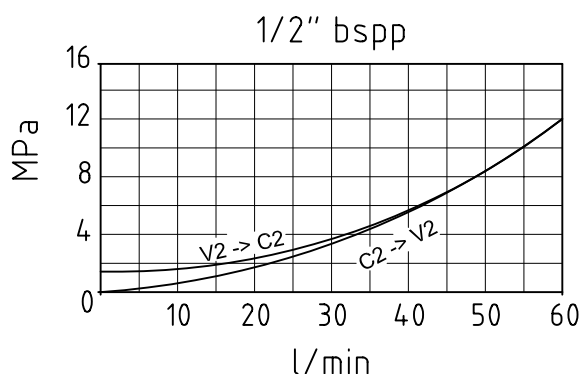
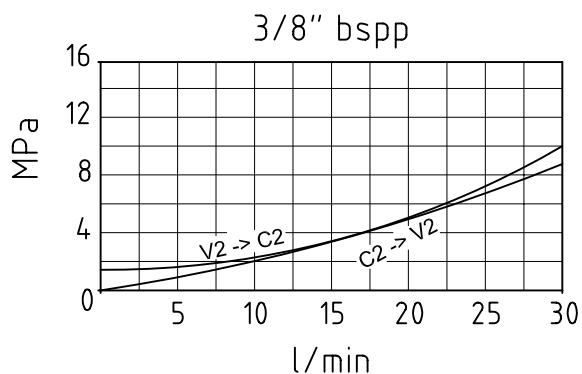
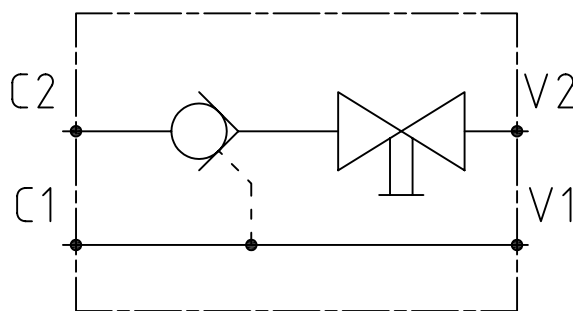

Description Bezeichnung	V1, V2, C1, C2	Max flow Volumenstrom	Pilot ratio Verstellungsverhältnis	H1	H2	H3	H	L1	L2	L3	L	S	R	ØF	Weight Gewicht
GVU-SE-RLD-38	3/8" BSPP	30 l/min - 7.9 gpm	5.4:1	415	28	10	90.5	37	22	10	65	35	82	9	0.6 kg
GVU-SE-RLD-12	1/2" BSPP	60 l/min - 15.8 gpm	3.6:1	40.5	35	10	82.5	50	30	10	50	35	82	9	1.0 kg

ORDERING INSTRUCTIONS - BESTELLANLEITUNG
114111
-
-
-
-
-
-
-
-
10
**Spring
Feder**

0	0.6 bar (only/nur 1/2" bspp)
2	1.6 bar (only/nur 3/8" bspp)

**Max flow
Volumenstrom**

3	30 l/min (only/nur 3/8" bspp)
4	60 l/min (only/nur 1/2" bspp)

**V1, V2,
C1, C2**

2	3/8" bspp
3	1/2" bspp

**Pilot ratio
Verstellungsverhältnis**

3	3.6:1 (only/nur 1/2" bspp)
5	5.4:1 (only/nur 3/8" bspp)

TECHNICAL DATA
TECHNISCHE ANGABEN

Max operating pressure Maximaler Betriebsdruck	35 MPa 5076 psi
Max flow Volumenstrom	see table/siehe Tabelle
Temperature range Betriebstemperatur	-20°/80°C
Filtration Filtergrad	40µ
Material Material	Zincoated Steel Verzinkter Stahl

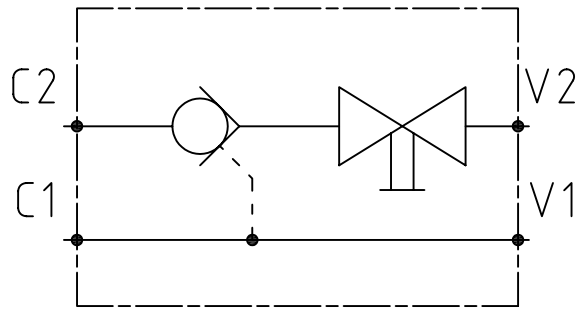
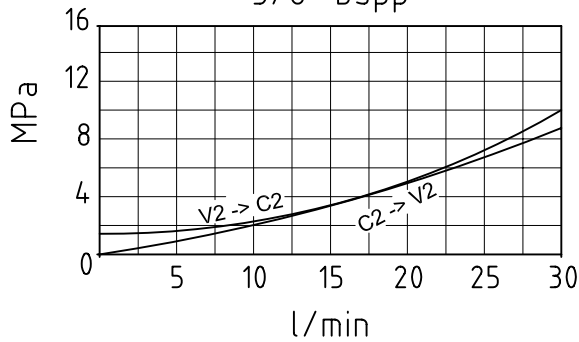
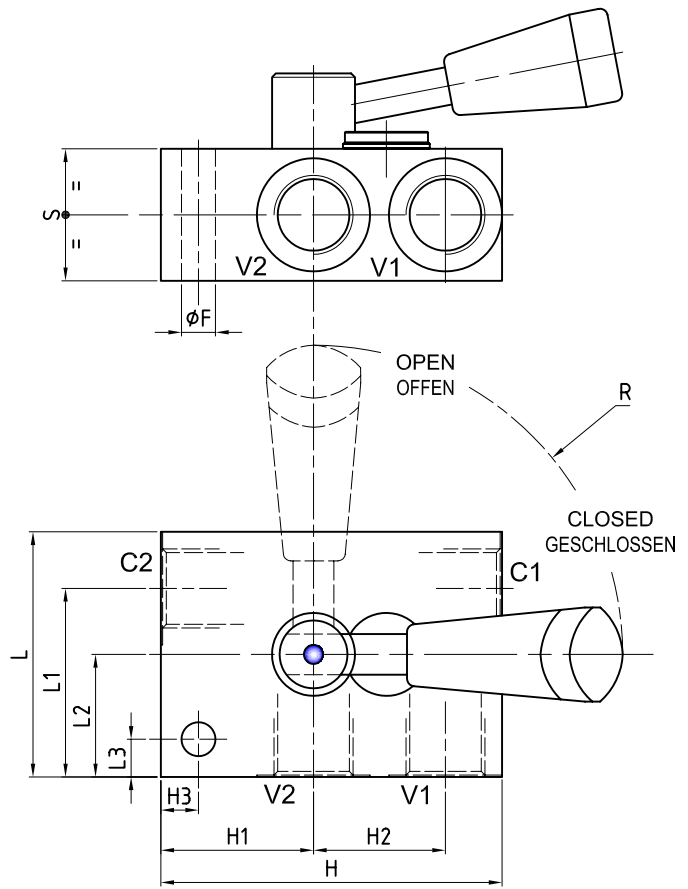
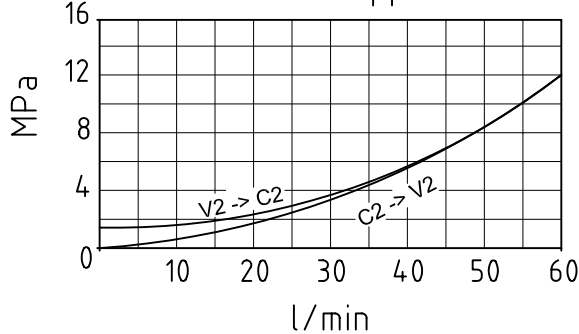
3/8" bspp

1/2" bspp

Description Bezeichnung	V1, V2, C1, C2	Max flow Volumenstrom	Pilot ratio Verstellungsverhältnis	H1	H2	H3	H	L1	L2	L3	L	S	R	ØF	Weight Gewicht
GVU-SE-RLS-38	3/8" BSPP	30 l/min - 7.9 gpm	5.4:1	415	28	10	90.5	37	22	10	65	35	82	9	0.6 kg
GVU-SE-RLS-12	1/2" BSPP	60 l/min - 15.8 gpm	3.6:1	40.5	35	10	82.5	50	30	10	50	35	82	9	1.0 kg

ORDERING INSTRUCTIONS - BESTELLANLEITUNG
114112
-
-
-
-
-
-
-
-
10
**Spring
Feder**

0	0.6 bar (only/nur 1/2" bspp)
2	1.6 bar (only/nur 3/8" bspp)

**Max flow
Volumenstrom**

3	30 l/min (only/nur 3/8" bspp)
4	60 l/min (only/nur 1/2" bspp)

**V1, V2,
C1, C2**

2	3/8" bspp
3	1/2" bspp

**Pilot ratio
Verstellungsverhältnis**

3	3.6:1 (only/nur 1/2" bspp)
5	5.4:1 (only/nur 3/8" bspp)

TECHNICAL DATA
TECHNISCHE ANGABEN

Max operating pressure Maximaler Betriebsdruck	see table/siehe Tabelle
Max flow Volumenstrom	see table/siehe Tabelle
Temperature range Betriebstemperatur	-20°/80°C
Filtration Filtergrad	40µ

	Weigth Gewicht
GULP-14-27	0.4 kg (Zincoated Steel/Verzink. Stahl)
GULP-38-30	0.4 kg (Zincoated Steel/Verzink. Stahl)
GULP-12-24	0.5 kg (Zincoated Steel/Verzink. Stahl)

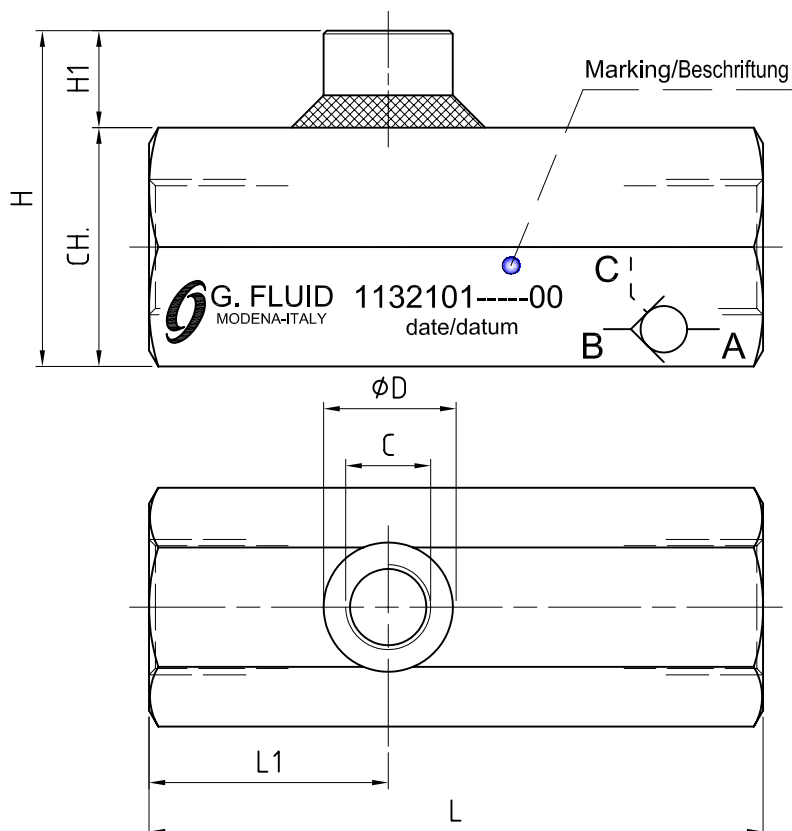
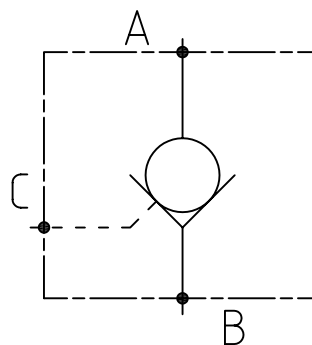
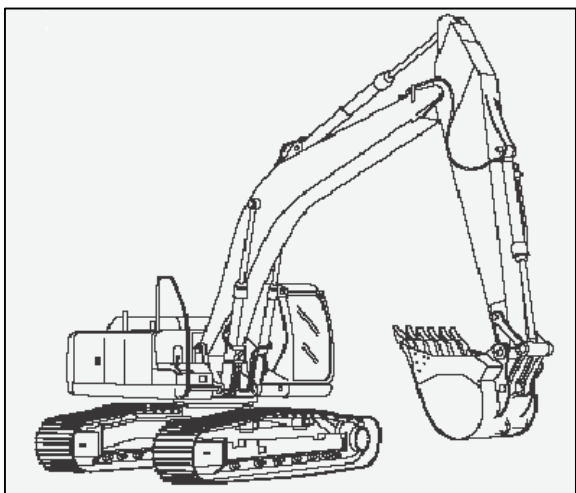
APPLICATION/ANWENDUNG

Description Bezeichnung	Max flow Volumenstrom	Max operating pressure Maximaler Betriebsdruck	Pilot ratio Versteuerverhältnis	L	L1	CH	H1	H	ØD	A, B	C
GULP-14-27	15 l/min - 3.9 gpm	70 MPa - 10150 psi	2.7:1	75	31.5	24	14.5	38.5		1/4" bspp	
GULP-38-30	35 l/min - 9.2 gpm	70 MPa - 10150 psi	3:1	85	31	27	14.5	41.5	20	3/8" bspp	1/4" bspp
GULP-12-24	55 l/min - 14.5 gpm	50 MPa - 7250 psi	2.4:1	95	37	32	15	47		1/2" bspp	

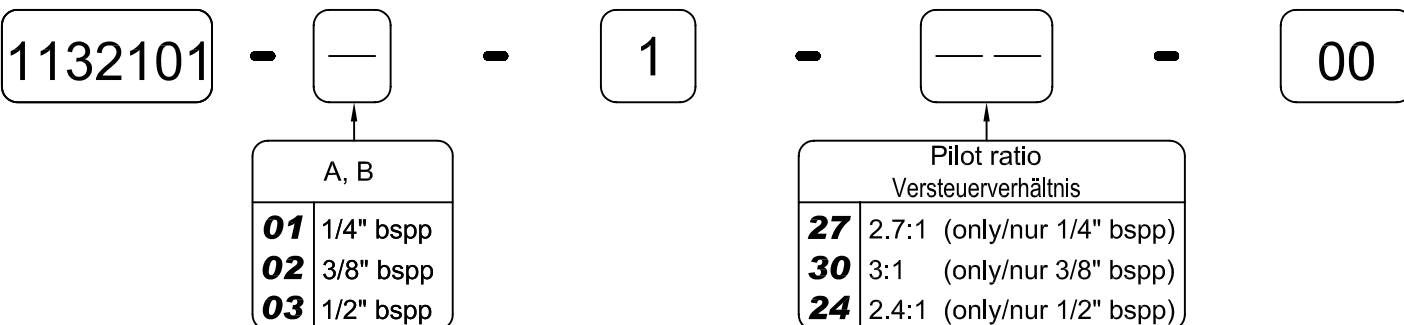
ORDERING INSTRUCTIONS - BESTELLANLEITUNG

**TECHNICAL DATA
TECHNISCHE ANGABEN**

Max operating pressure Maximaler Betriebsdruck	35 MPa 5076 psi
Max flow Volumenstrom	20 l/min 5.3 gpm
Temperature range Betriebstemperatur	-20°/80°C
Filtration Filtergrad	40μ
Weight Gewicht	0.7 kg
Material Material	Zincoated Steel Verzinkter Stahl

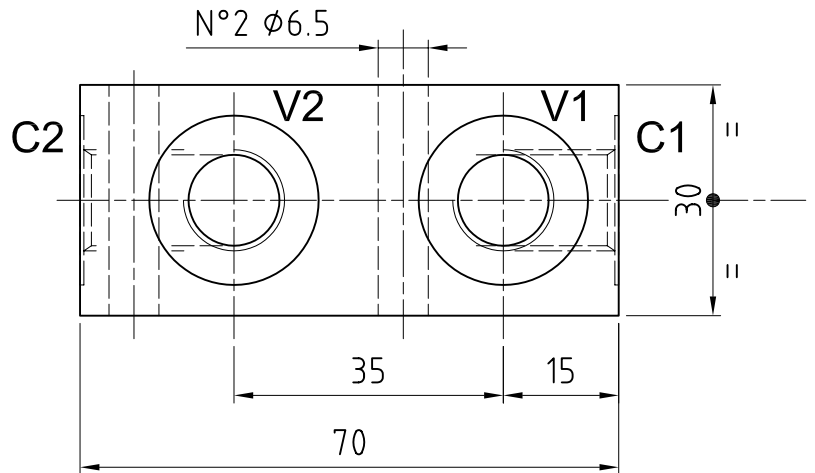
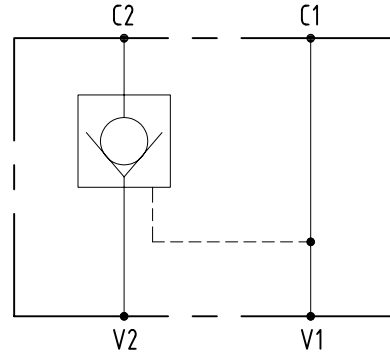
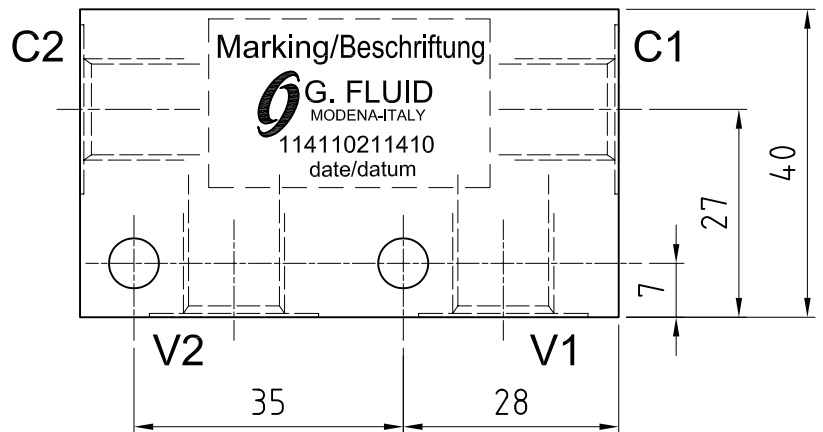
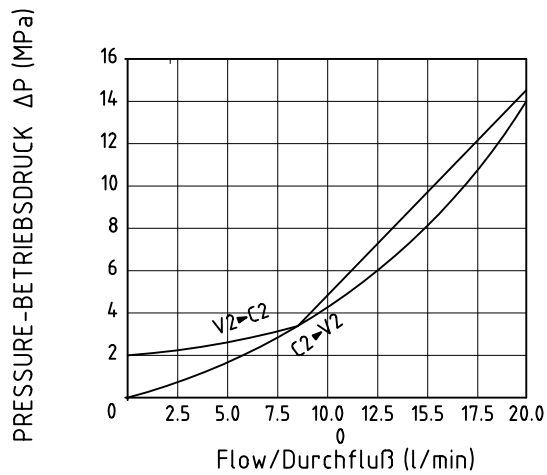
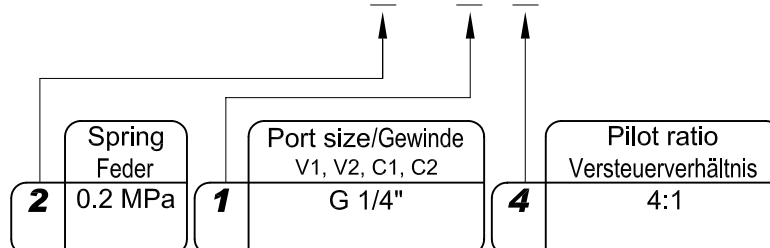

Diagram/Diagramm

ORDERING INSTRUCTIONS - BESTELLANLEITUNG
114110 1 10

TECHNICAL DATA
TECHNISCHE ANGABEN

Max operating pressure Maximaler Betriebsdruck	21 MPa-2987 psi (Alloy/Aluminium) 35 MPa-5076 psi (Zincoated Steel/Verzink. Stahl)
Max flow Volumenstrom	30 l/min - 50 l/min - 80 l/min 7.9 gpm - 13.2 gpm - 21.1 gpm
Temperature range Betriebstemperatur	-20°/80°C
Filtration Filtergrad	40µ

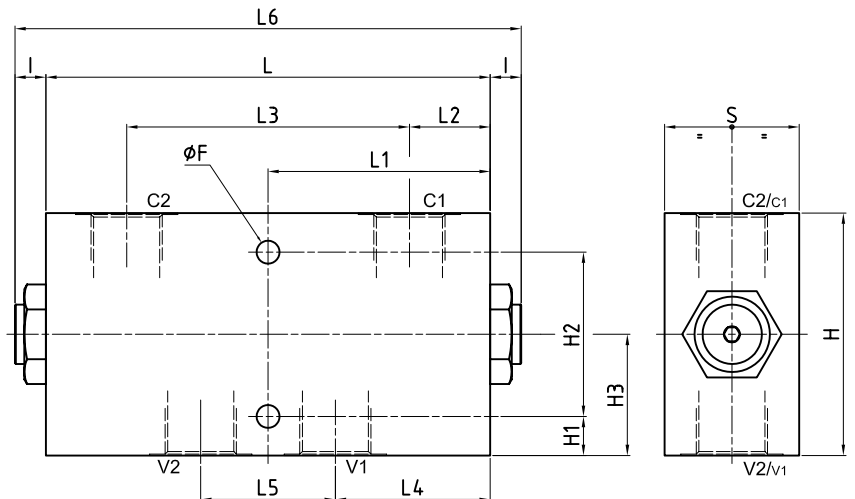
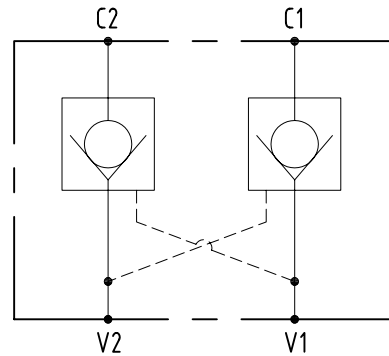
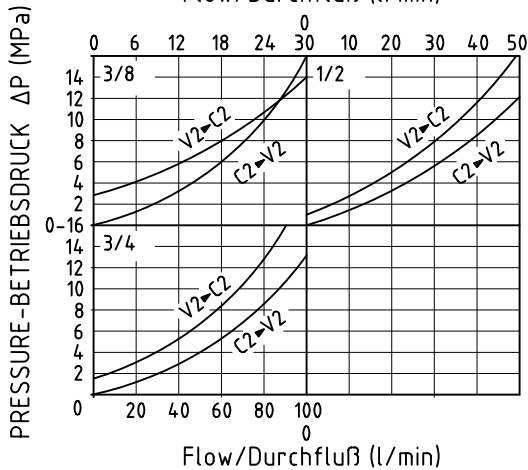
Weight
Gewicht

GVU-DE-38A27 GVU-DE-38A47	0.6 kg (Alloy/Aluminium)
GVU-DE-38S27 GVU-DE-38S47	1.5 kg (Zincoated Steel/Verzink. Stahl)
GVU-DE-12A23 GVU-DE-12A43	0.9 kg (Alloy/Aluminium)
GVU-DE-12S23 GVU-DE-12S43	2.1 kg (Zincoated Steel/Verzink. Stahl)
GVU-DE-34A24 GVU-DE-34A44	2.1 kg (Alloy/Aluminium)
GVU-DE-34S24 GVU-DE-34S44	5.8 kg (Zincoated Steel/Verzink. Stahl)

Diagram/Diagramm
Flow/Durchfluß (l/min)

		Description		C1,C2,V1,V2 bspp	L	L1	L2	L3	L4	L5	I	L6	H	H1	H2	H3	S	F
Spring	Pilot ratio	Alloy	Zincoated Steel															
2	7	GVU-DE-38A27	GVU-DE-38S27	3/8"	96	48	17	62	32	32	10	116	60	9.5	4.1	30	35	6.5
4		GVU-DE-38A47	GVU-DE-38S47															
2	3	GVU-DE-12A23	GVU-DE-12S23	1/2"	120	60	20.5	79	4.3	34	11.5	143	70	14.5	4.1	35	37.5	8.5
4		GVU-DE-12A43	GVU-DE-12S43															
2	4	GVU-DE-34A24	GVU-DE-34S24	3/4"	165	82.5	30	105	57.5	50	11.5	188	90	14.5	6.1	45	50	8.5
4		GVU-DE-34A44	GVU-DE-34S44															

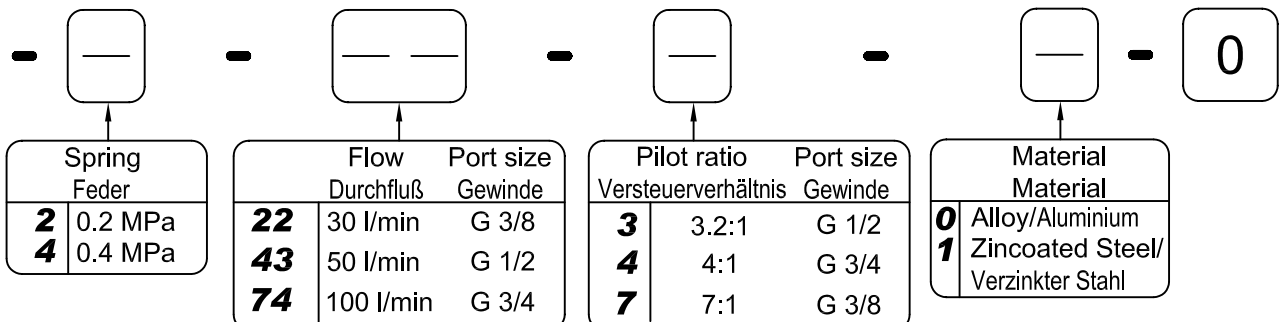
ORDERING INSTRUCTIONS - BESTELLANLEITUNG
114201

GVU-DE-F1

TECHNICAL DATA
TECHNISCHE ANGABEN

Max operating pressure Maximaler Betriebsdruck	21 MPa-2987 psi (Alloy/Aluminium) 35 MPa-5076 psi (Zincoated Steel/Verzink. Stahl)
Max flow Volumenstrom	30 l/min - 50 l/min - 80 l/min 7.9 gpm - 13.2 gpm - 21.1 gpm
Temperature range Betriebstemperatur	-20°/80°C
Filtration Filtergrad	40µ

Weigth
Gewicht

GVU-DE-F1-38A24 / GVU-DE-F1-38A27 GVU-DE-F1-38A44 / GVU-DE-F1-38A47	0,6 kg (Alloy/Aluminium)
GVU-DE-F1-38S24 / GVU-DE-F1-38S27 GVU-DE-F1-38S44 / GVU-DE-F1-38S47	1,5 kg (Zincoated Steel/Verzink. Stahl)
GVU-DE-F1-12A24 / GVU-DE-F1-12A27 GVU-DE-F1-12A44 / GVU-DE-F1-12A47	0,9 kg (Alloy/Aluminium)
GVU-DE-F1-12S24 / GVU-DE-F1-12S27 GVU-DE-F1-12S44 / GVU-DE-F1-12S47	2,1 kg (Zincoated Steel/Verzink. Stahl)
GVU-DE-F1-34A24 / GVU-DE-F1-34A27 GVU-DE-F1-34A44 / GVU-DE-F1-34A47	2,1 kg (Alloy/Aluminium)
GVU-DE-F1-34S24 / GVU-DE-F1-34S27 GVU-DE-F1-34S44 / GVU-DE-F1-34S47	5,8 kg (Zincoated Steel/Verzink. Stahl)

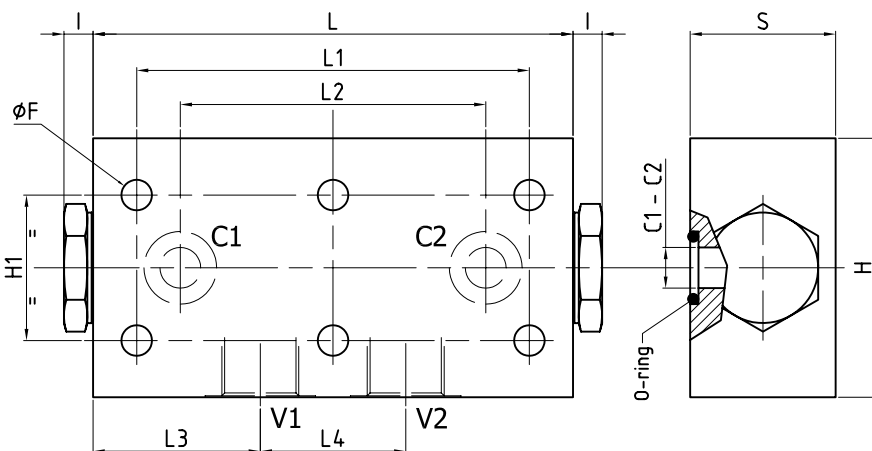
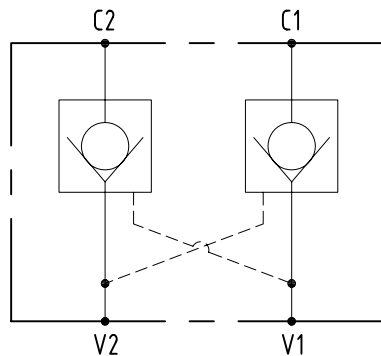
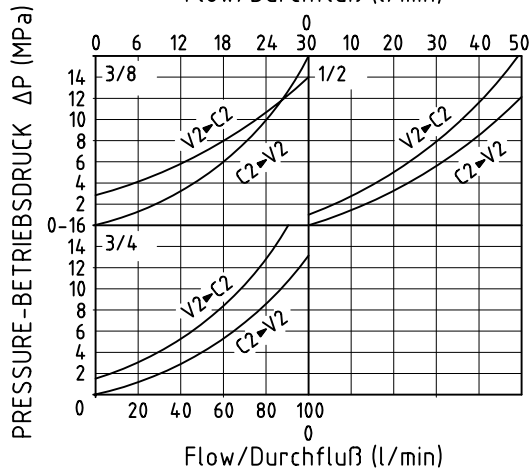
Diagram/Diagramm
Flow/Durchfluß (l/min)

Spring		Pilot ratio		Description		V1, V2	C1, C2	L	L1	L2	L3	L4	I	H	H1	S	F	O-ring	
2	4	4	7	Alloy	Zincoated Steel	bspp	φ												
2	4	GVU-DE-F1-38A24	GVU-DE-F1-38S24																
2	7	GVU-DE-F1-38A27	GVU-DE-F1-38S27			3/8"	6	90	70	62	32	32	14	60	40	34	6.5	9.19x2.62	
4	4	GVU-DE-F1-38A44	GVU-DE-F1-38S44																
4	7	GVU-DE-F1-38A47	GVU-DE-F1-38S47																
2	4	GVU-DE-F1-12A24	GVU-DE-F1-12S24			1/2"	10	110	80	65	38	34	10	70	40	34	8.5	15.34x2.62	
2	7	GVU-DE-F1-12A27	GVU-DE-F1-12S27																
4	4	GVU-DE-F1-12A44	GVU-DE-F1-12S44																
4	7	GVU-DE-F1-12A47	GVU-DE-F1-12S47																
2	4	GVU-DE-F1-34A24	GVU-DE-F1-34S24			3/4"	14	165	135	105	57.5	50	10	90	50	49	10.5	18.64x3.53	
2	7	GVU-DE-F1-34A27	GVU-DE-F1-34S27																
4	4	GVU-DE-F1-34A44	GVU-DE-F1-34S44																
4	7	GVU-DE-F1-34A47	GVU-DE-F1-34S47																

ORDERING INSTRUCTIONS - BESTELLANLEITUNG
115201

Spring Feder	
2	0.2 MPa
4	0.4 MPa

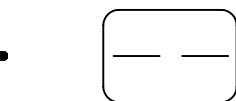

Flow Durchfluß	Port size Gewinde
22	30 l/min G 3/8
43	50 l/min G 1/2
74	100 l/min G 3/4



Pilot ratio Verstellverhältnis	
4	4:1
7	7:1



Material Material	
0	Alloy/Aluminium
1	Zincoated Steel/ Verzinkter Stahl

0

TECHNICAL DATA
TECHNISCHE ANGABEN

Max operating pressure Maximaler Betriebsdruck	35 MPa 5076 psi
Max flow Volumenstrom	40 l/min 10.6 gpm
Temperature range Betriebstemperatur	-20°/80°C
Filtration Filtergrad	40µ
Weight Gewicht	2.8 kg
Material Material	Zincoated Steel Verzinkter Stahl
Pilot ratio Steuerverhältnis	7:1

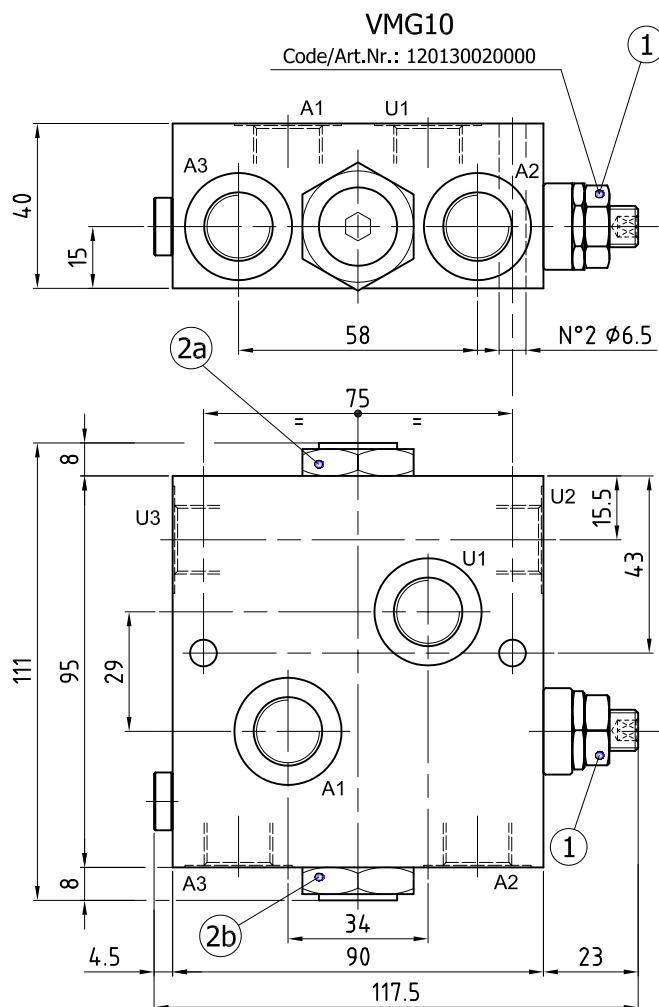
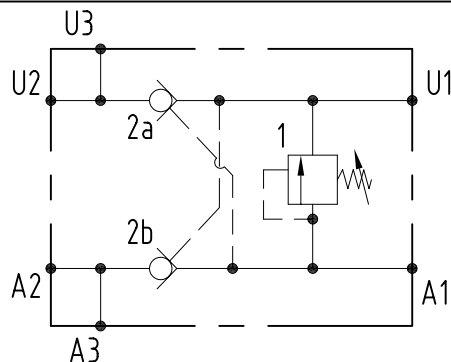
PORT SIZE
GEWINDE

A1, A2, A3, U1, U2, U3	G 3/8"

ORDERING INSTRUCTIONS - BESTELLANLEITUNG
024.04.04.00

VBG-SE-61

An overcenter valve with compact dimensions and good tolerance to oil contamination. The steel body is designed for heavy duty applications. Pressure setting at least 1.3 times the load induced pressure.

Dieses Ventil ist durch seine kompakten Maße und seine gute Toleranz bezüglich einer eventuellen Ölverschmutzung gekennzeichnet. Dank seines Stahlgehäuses ist dieses Ventil auch für schwere Anwendungen geeignet. Sehr gute Kontrolle innerhalb eines weiten Volumenstrom- und Druckbereiches. Druckeinstellung 1.3x Ladedruck.

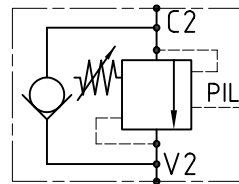

TECHNICAL DATA TECHNISCHE ANGABEN	
Max operating pressure Maximaler Betriebsdruck	21 MPa-2987 psi (Alloy/Aluminium) 35 MPa-5076 psi (Zincoated Steel/Verzink. Stahl)
Max flow Volumenstrom	40 l/min 10.6 gpm
Temperature range Betriebstemperatur	-20°/80°C
Filtration Filtergrad	40µ

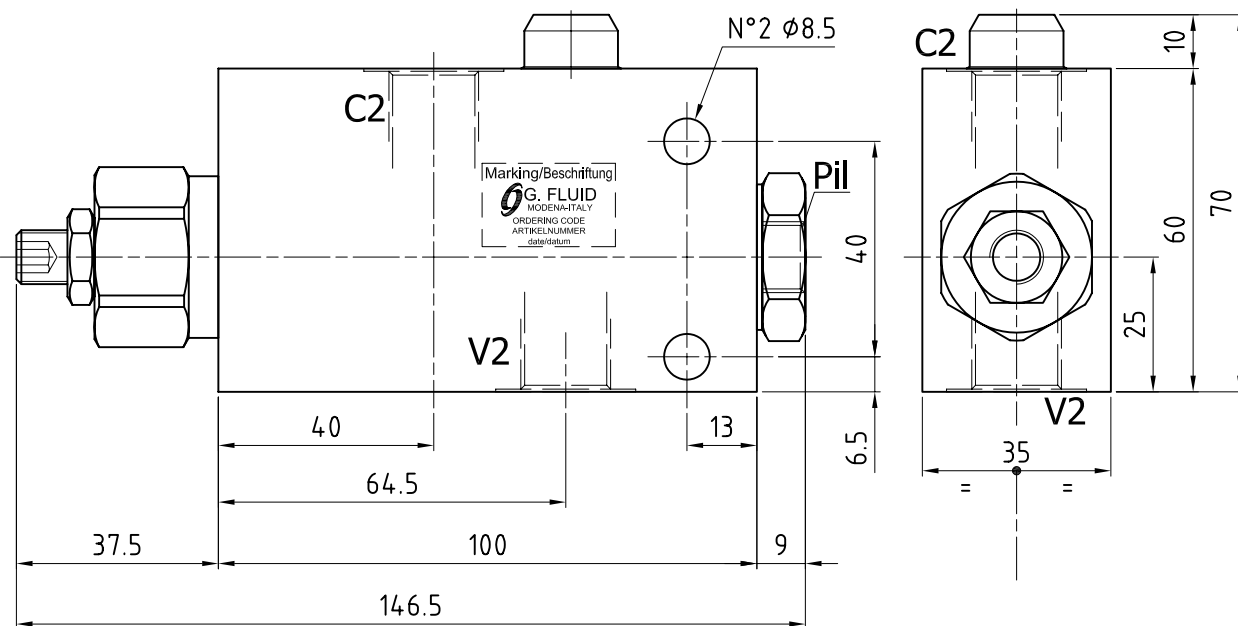
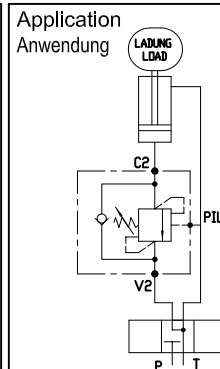
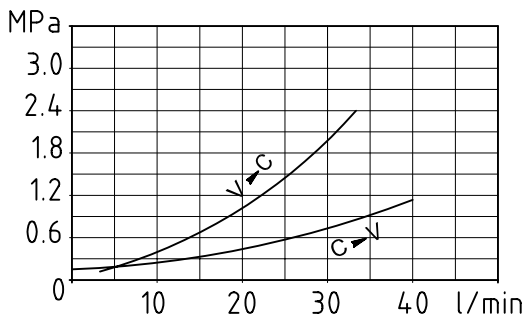

ORDERING CODE - ARTIKELNUMMER

144161 00

Pilot ratio Steuerverhältnis		Adj. range Regelbereich		std setting Standardeinst.		Pressure increase MPa/tum Drucksteigerung MPa je Schraubendrehung		Port size/Gewinde V2, C2 Pijl		Material Material		Weigth Gewicht	Description Bezeichnung
02	2:1	1	6-21 MPa	20 MPa	4.4	02	G 3/8"	G 1/4"	0	Alloy/Aluminium	0.7 kg	VBG-SE-61-A	
13	3.6:1	2	10-35 MPa	35 MPa	8.0				1	Zincoated Steel/ Verzinkter Stahl	1.8 kg	VBG-SE-61-S	
19	9.1:1												

VBG-SE-62

An overcenter valve with compact dimensions and good tolerance to oil contamination. The steel body is designed for heavy duty applications. Pressure setting at least 1.3 times the load induced pressure.

Dieses Ventil ist durch seine kompakten Maße und seine gute Toleranz bezüglich einer eventuellen Ölverschmutzung gekennzeichnet. Dank seines Stahlgehäuses ist dieses Ventil auch für schwere Anwendungen geeignet. Sehr gute Kontrolle innerhalb eines weiten Volumenstrom- und Druckbereiches. Druckeinstellung 1.3x Ladedruck.

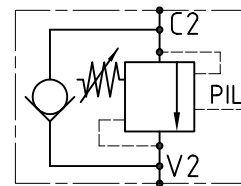

TECHNICAL DATA TECHNISCHE ANGABEN

Max operating pressure Maximaler Betriebsdruck	21 MPa-2987 psi (Alloy/Aluminium) 35 MPa-5076 psi (Zincoated Steel/Verzink. Stahl)
Max flow Volumenstrom	40 l/min 10.6 gpm
Temperature range Betriebstemperatur	-20°/80°C
Filtration Filtergrad	40µ

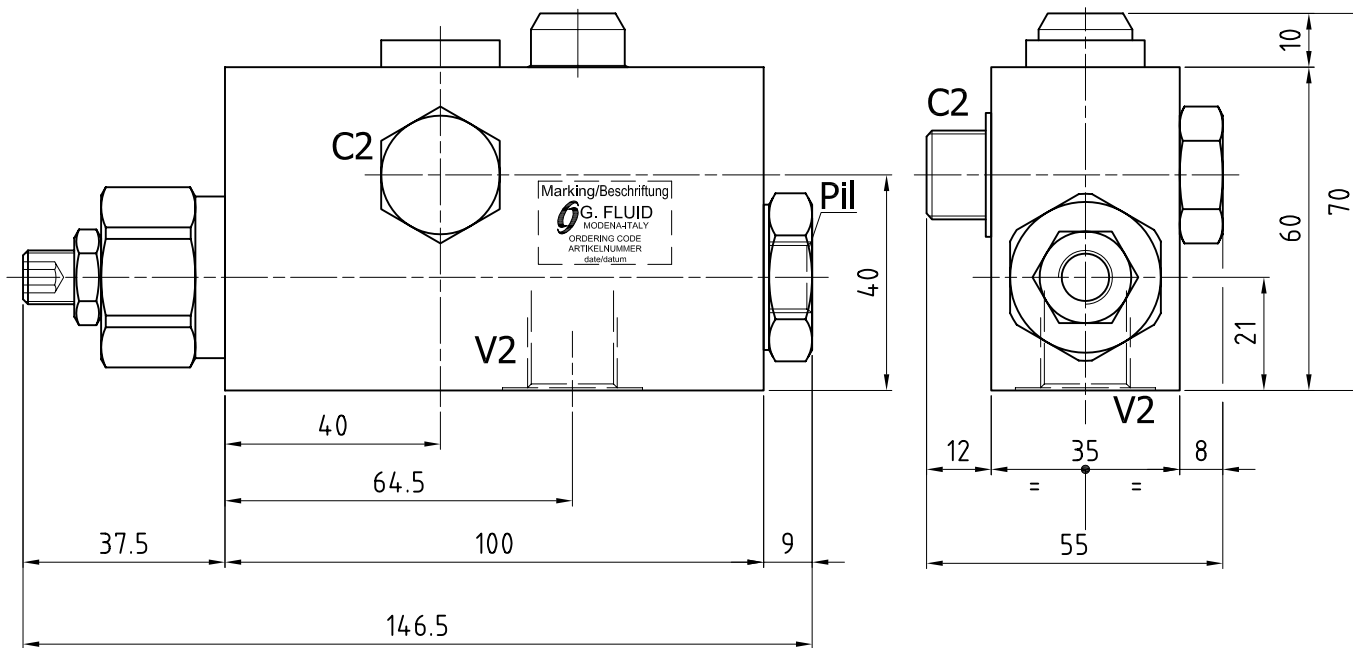
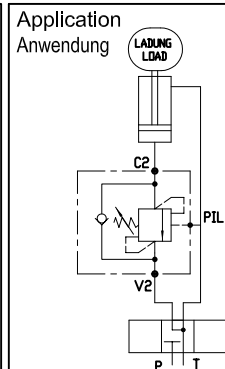
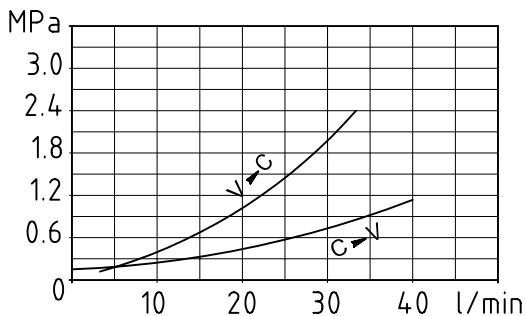

ORDERING CODE - ARTIKELNUMMER

144162 00

	Pilot ratio Steuerverhältnis	Adj. range Regelbereich	std setting Standardeinst.	Pressure increase MPa/tum Drucksteigerung MPa je Schraubendrehung	Port size/Gewinde V2, C2 Pil	Material Material	Weigth Gewicht	Description Bezeichnung
02	2:1	1 6-21 MPa	20 MPa	4.4	02 G 3/8"	0 Alloy/Aluminium	0.9 kg	VBG-SE-62-A
13	3.6:1	2 10-35 MPa	35 MPa	8.0	G 1/4"	1 Zincoated Steel/ Verzinkter Stahl	2.5 kg	VBG-SE-62-S
19	9.1:1							

An overcenter valve with compact dimensions and good tolerance to oil contamination. It uses same components as PB010 valve, with excellent control in a wide flow and pressure range. The steel body is designed for heavy duty applications. Pressure setting at least 1.3 times the load induced pressure.

Dieses Ventil ist durch seine kompakten Maße und seine gute Toleranz bezüglich einer eventuellen Ölverschmutzung gekennzeichnet. Es besteht aus den gleichen Komponenten wie das Ventil PB010. Dank seines Stahlgehäuses ist dieses Ventil auch für schwere Anwendungen geeignet. Sehr gute Kontrolle innerhalb eines weiten Volumenstrom- und Druckbereiches. Druckeinstellung 1.3x Ladedruck.

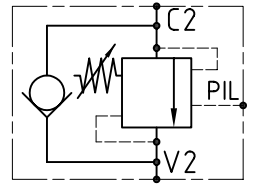

TECHNICAL DATA TECHNISCHE ANGABEN	
Max operating pressure Maximaler Betriebsdruck	21 MPa-2987 psi (Alloy/Aluminium) 35 MPa-5076 psi (Zincoated Steel/Verzink. Stahl)
Max flow Volumenstrom	40 l/min 10.6 gpm
Temperature range Betriebstemperatur	-20°/80°C
Filtration Filtergrad	40µ
Pilot ratio Versteuerverhältnis	4.1:1

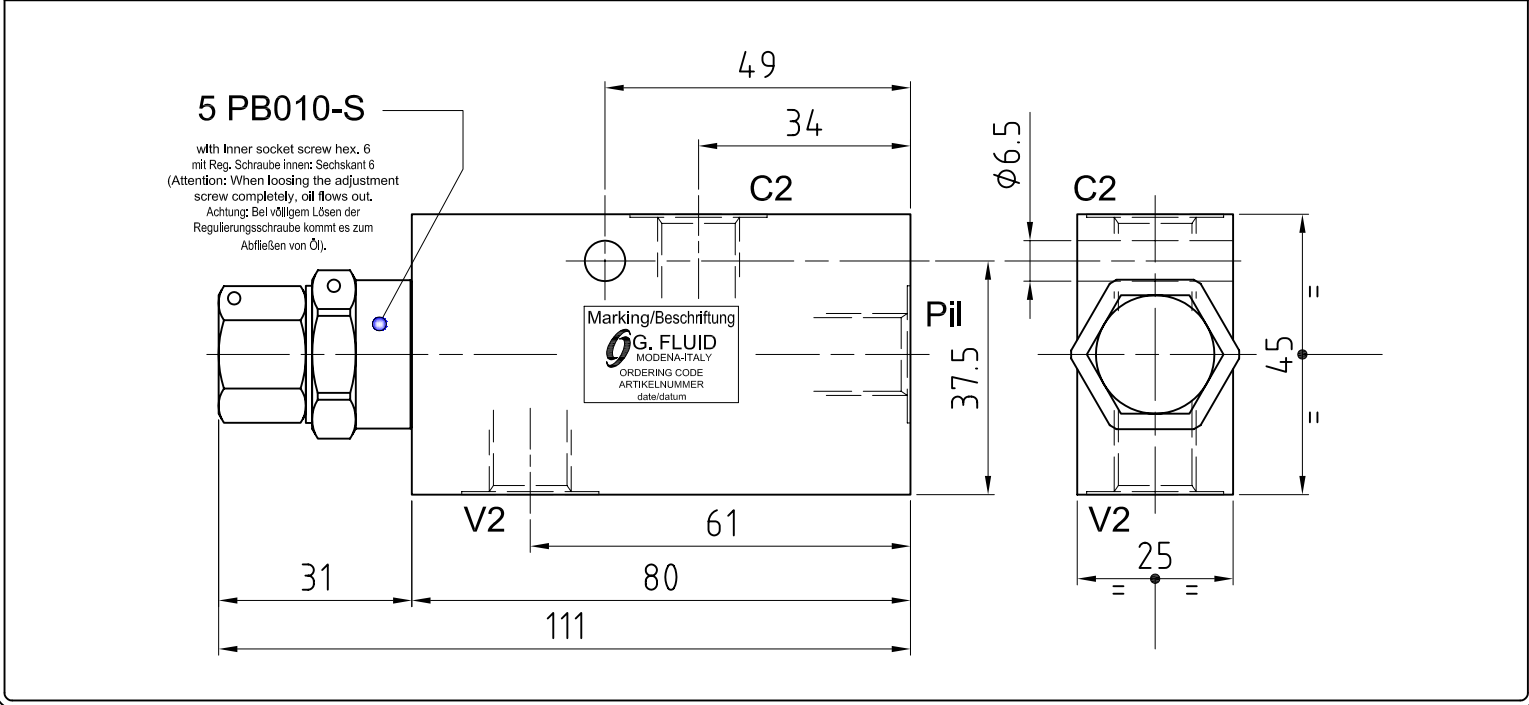
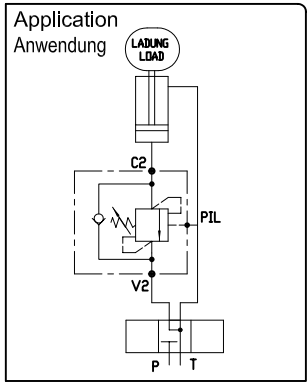
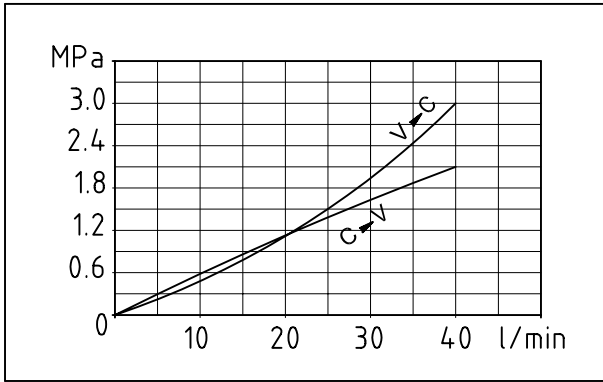

ORDERING CODE - ARTIKELNUMMER
14410806

2	Adj. range Regelbereich	std setting Standardeinst.	Pressure increase MPa/turn Drucksteigerung MPa je Schraubendrehung	01	Port size/Gewinde V2, C2, Pil	0	Material Material	Weigth Gewicht	Description Bezeichnung
	10-35 MPa	30 MPa	11.6		G 1/4"	1	AlloyAluminium Zincoated Steel/ Verzinkter Stahl	0.4 kg 0.8 kg	VBG-SE-78-A VBG-SE-78-S

VBG-SE-63

An overcenter valve with compact dimensions and good tolerance to oil contamination.
 The steel body is designed for heavy duty applications.
 Pressure setting at least 1.3 times the load induced pressure.

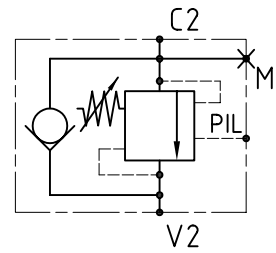
Dieses Ventil ist durch seine kompakten Maße und seine gute Toleranz bezüglich einer eventuellen Ölverschmutzung gekennzeichnet.
 Dank seines Stahlgehäuses ist dieses Ventil auch für schwere Anwendungen geeignet. Sehr gute Kontrolle innerhalb eines weiten Volumenstrom- und Druckbereiches.
 Druckeinstellung 1.3x Ladedruck.

TECHNICAL DATA
TECHNISCHE ANGABEN

Max operating pressure Maximaler Betriebsdruck	21 MPa-2987 psi (Alloy/Aluminium) 35 MPa-5076 psi (Zincoated Steel/Verzink. Stahl)
Max flow Volumenstrom	70 l/min 18.5 gpm
Temperature range Betriebstemperatur	-20°/80°C
Filtration Filtergrad	40µ

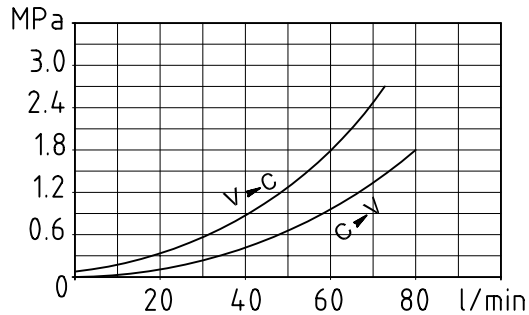
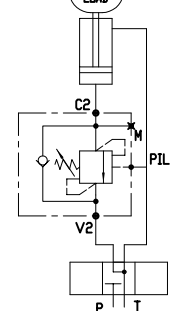
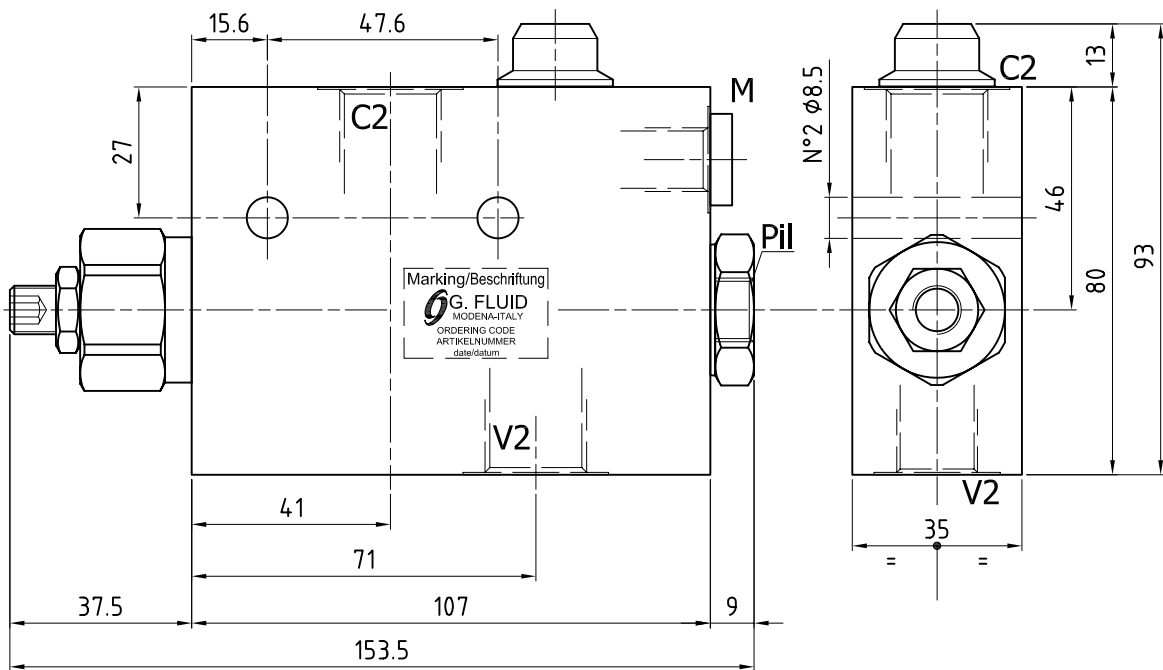
Application
Anwendung

ORDERING CODE - ARTIKELNUMMER
144163 00

03	Pilot ratio Steuerverhältnis	3:1	1	Adj. range Regelbereich	6-21 MPa	std setting Standardeinst.	20 MPa	Pressure increase MPa/turn Drucksteigerung MPa je Schraubendrehung	4.4	03	Port size/Gewinde V2, C2	G 1/2"	Pil, M	G 1/4"	0	Material Material	Alloy/Aluminium	Weigth Gewicht	1.1 kg	Description Bezeichnung	VBG-SE-63-A
15		10.5:1	2		10-35 MPa		35 MPa		8.0						1		Zincoated Steel/ Verzinkter Stahl		3.0 kg		VBG-SE-63-S

An overcenter valve with compact dimensions and good tolerance to oil contamination.
 The steel body is designed for heavy duty applications.
 Pressure setting at least 1.3 times the load induced pressure.

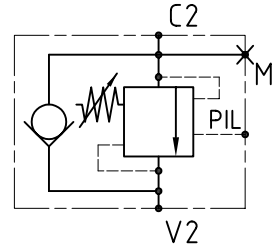
Dieses Ventil ist durch seine kompakten Maße und seine gute Toleranz bezüglich einer eventuellen Ölverschmutzung gekennzeichnet.
 Dank seines Stahlgehäuses ist dieses Ventil auch für schwere Anwendungen geeignet. Sehr gute Kontrolle innerhalb eines weiten Volumenstrom- und Druckbereiches.
 Druckeinstellung 1.3x Ladedruck.

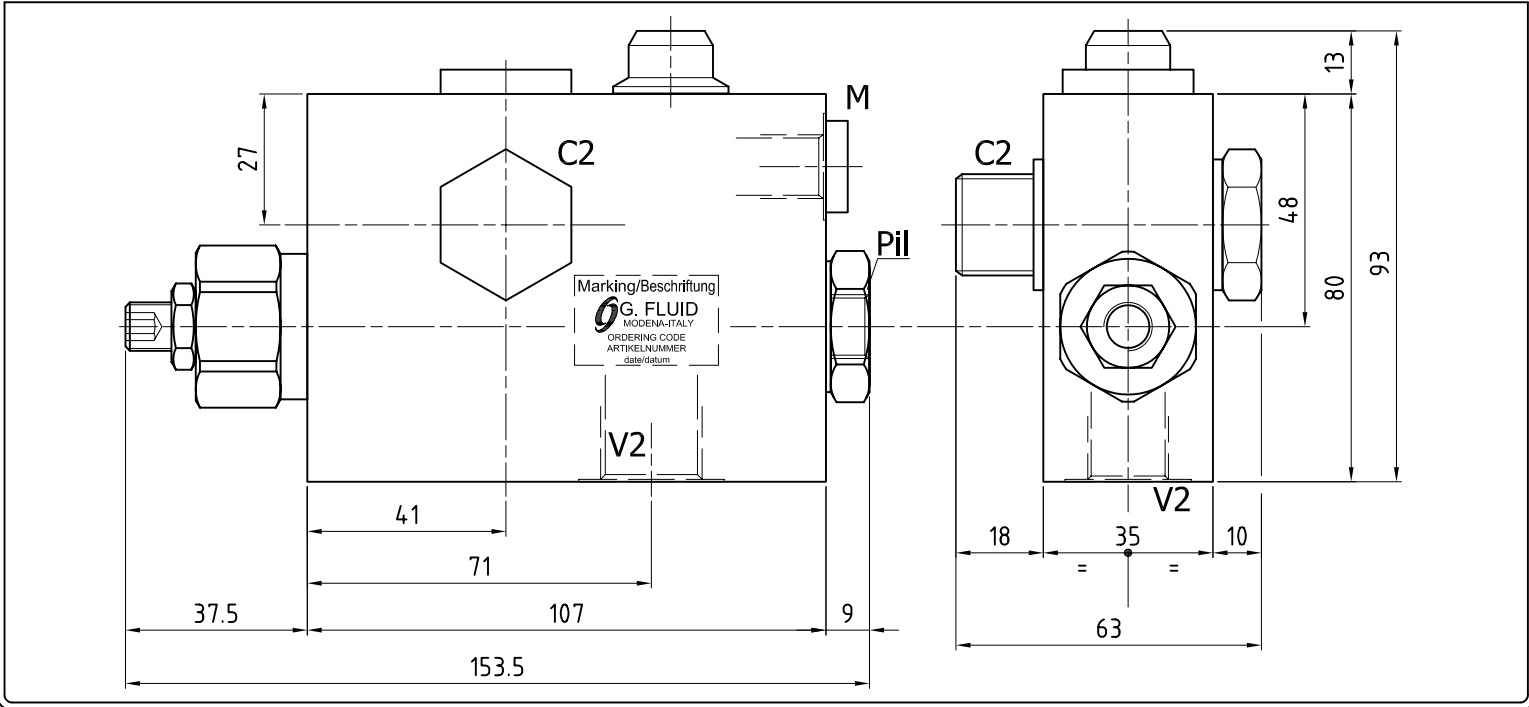
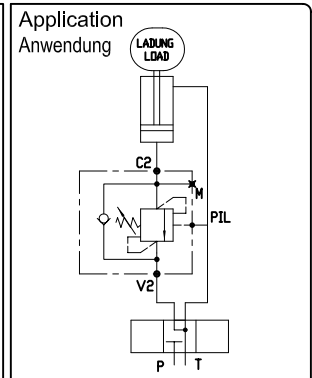
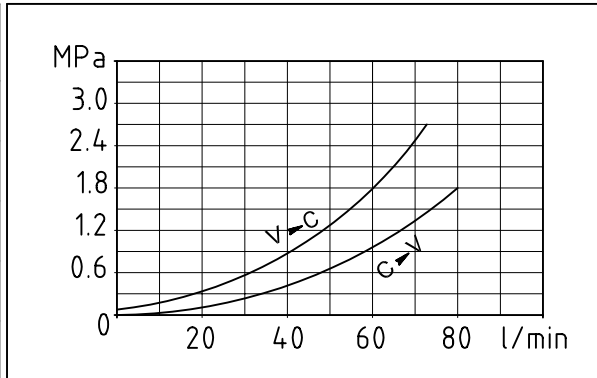

TECHNICAL DATA TECHNISCHE ANGABEN	
Max operating pressure Maximaler Betriebsdruck	21 MPa-2987 psi (Alloy/Aluminium) 35 MPa-5076 psi (Zincoated Steel/Verzink. Stahl)
Max flow Volumenstrom	70 l/min 18.5 gpm
Temperature range Betriebstemperatur	-20°/80°C
Filtration Filtergrad	40µ

ORDERING CODE - ARTIKELNUMMER
144164 00

Pilot ratio Steuerverhältnis	Adj. range Regelbereich	std setting Standardeinst.	Pressure increase MPa/turn Drucksteigerung MPa je Schraubendrehung	Port size/Gewinde V2, C2 Pil, M	Material Material	Weigth Gewicht	Description Bezeichnung
03 3:1	1 6-21 MPa	20 MPa	4.4	03 G 1/2"	0 Alloy/Aluminium	1.1 kg	VBG-SE-63-A
15 10.5:1	2 10-35 MPa	35 MPa	8.0	G 1/4"	1 Zincoated Steel/ Verzinkter Stahl	3.0 kg	VBG-SE-63-S

An overcenter valve with compact dimensions and good tolerance to oil contamination. It uses same components as PB012 valve, with excellent control in a wide flow and pressure range.

The steel body is designed for heavy duty applications.

Pressure setting at least 1.3 times the load induced pressure.

Dieses Ventil ist durch seine kompakten Maße und seine gute Toleranz bezüglich einer eventuellen Ölverschmutzung gekennzeichnet. Es besteht aus den gleichen Komponenten wie das Ventil PB012. Dank seines Stahlgehäuses ist dieses Ventil auch für schwere Anwendungen geeignet. Sehr gute Kontrolle innerhalb eines weiten Volumenstrom- und Druckbereiches.

Druckeinstellung 1.3x Ladedruck.

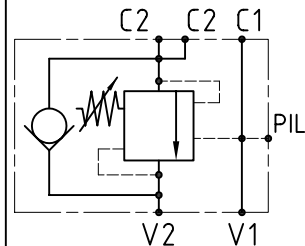
TECHNICAL DATA
TECHNISCHE ANGABEN

Max operating pressure Maximaler Betriebsdruck	21 MPa-2987 psi (Alloy/Aluminium) 35 MPa-5076 psi (Zincoated Steel/Verzinkt. Stahl)
Max flow Volumenstrom	60 l/min 15.9 gpm
Temperature range Betriebstemperatur	-20°/80°C
Filtration Filtergrad	40µ
Pilot ratio Versteuerverhältnis	4.25:1

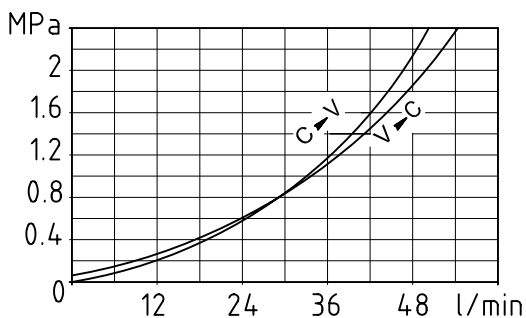
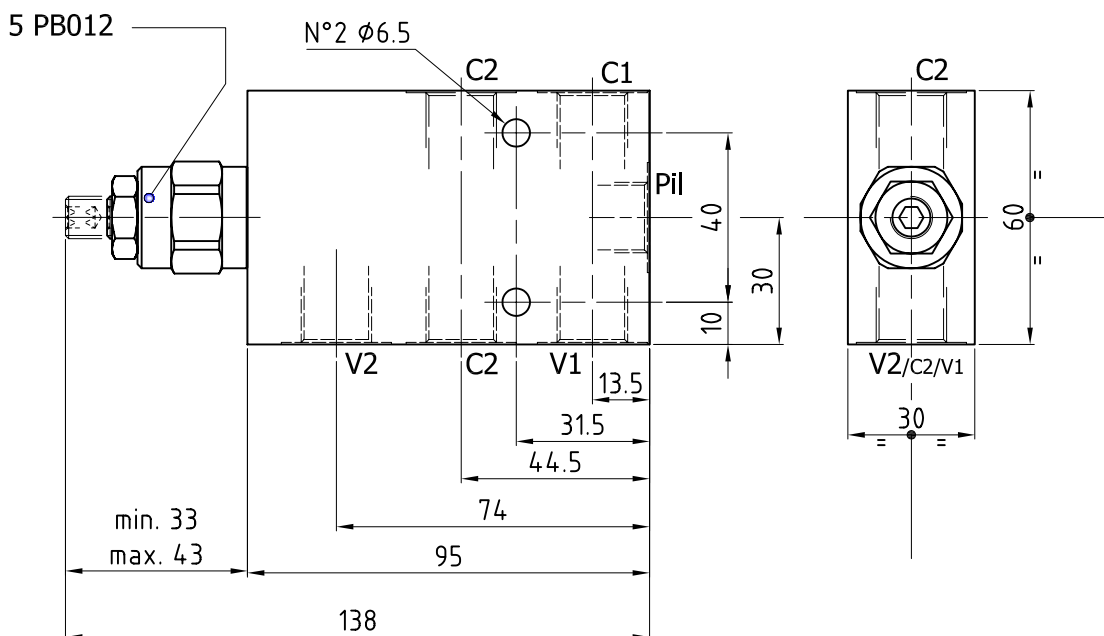
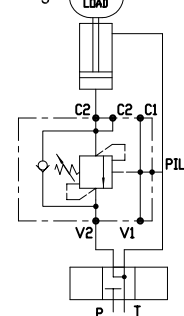
Application
Anwendung

ORDERING INSTRUCTIONS - BESTELLANLEITUNGEN
14 41 09 10 X Y W

Spring pressure range Feder-Einstellbereich	Pressure increase MPa/turn Drucksteigerung MPa je Schraubendrehung	Standard setting MPa Standard Einstellung MPa	X
6-21 MPa	5.6	20	1
10-35 MPa	10	35	2

W	Material Material
0	Steel / Stahl
1	Alloy / Aluminium
Z	Thread - Gewinde V1, V2, C1, C2, Pil
01	1/4" BSPP
02	3/8" BSPP

VBG-SE-30

An overcenter valve with compact dimensions and good tolerance to oil contamination. It uses same components as PB012 valve, with excellent control in a wide flow and pressure range. The steel body is designed for heavy duty applications. Pressure setting at least 1.3 times the load induced pressure.

Dieses Ventil ist durch seine kompakten Maße und seine gute Toleranz bezüglich einer eventuellen Ölverschmutzung gekennzeichnet. Es besteht aus den gleichen Komponenten wie das Ventil PB012. Dank seines Stahlgehäuses ist dieses Ventil auch für schwere Anwendungen geeignet. Sehr gute Kontrolle innerhalb eines weiten Volumenstrom- und Druckbereiches. Druckeinstellung 1.3x Ladedruck.

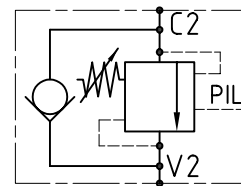

TECHNICAL DATA TECHNISCHE ANGABEN

Max operating pressure Maximaler Betriebsdruck	21 MPa-2987 psi (Alloy/Aluminium) 35 MPa-5076 psi (Zincoated Steel/Verzink. Stahl)
Max flow Volumenstrom	60 l/min 15.9 gpm
Temperature range Betriebstemperatur	-20°/80°C
Filtration Filtergrad	40µ
Pilot ratio Versteuerverhältnis	4.25:1

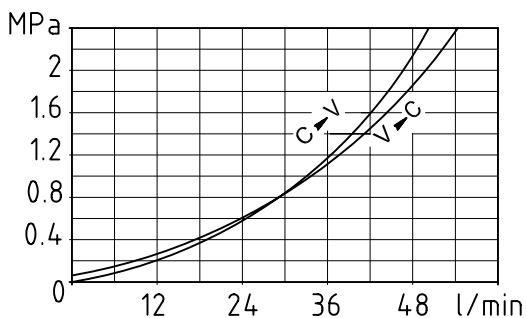

Application Anwendung

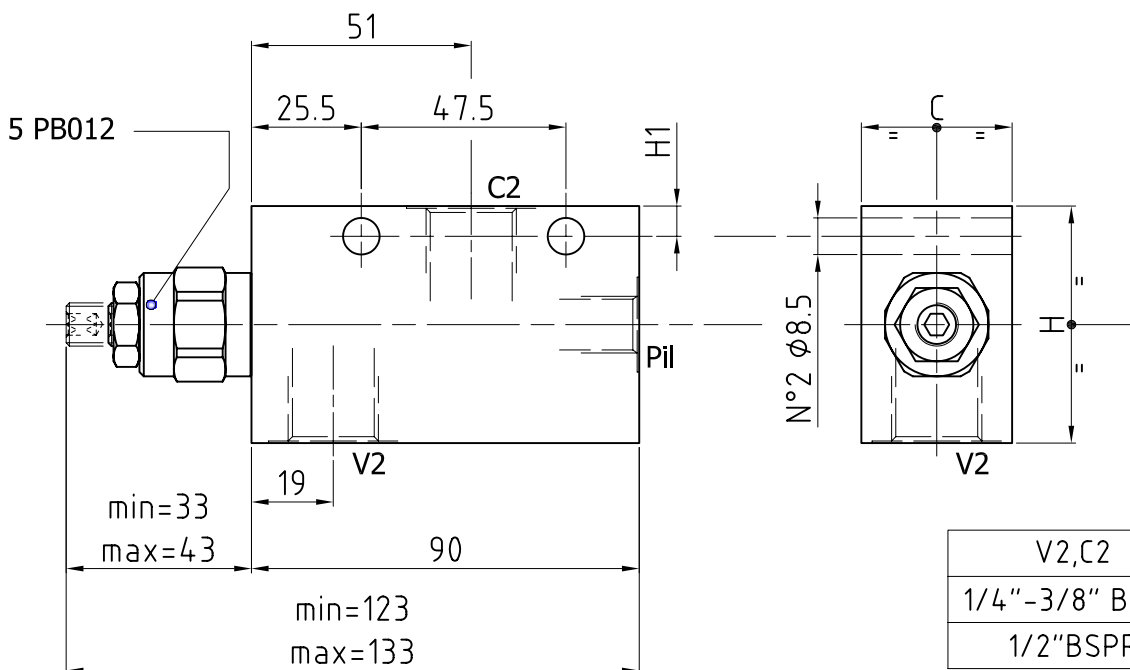
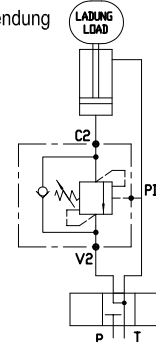

ORDERING INSTRUCTIONS - BESTELLANLEITUNGEN

14 41 10 10 **X Y W**

Spring pressure range Feder-Einstellbereich	Pressure increase MPa/turn Drucksteigerung MPa je Schraubendrehung	Standard setting MPa Standard Einstellung MPa	X
6-21 MPa	5.6	20	1
10-35 MPa	10	35	2

W	Material Material
0	Steel / Stahl
1	Alloy / Aluminium
Z	Thread - Gewinde V1, V2, C1,C2
01	1/4" BSPP
02	3/8" BSPP
03	1/2" BSPP

An overcenter valve with compact dimensions and good tolerance to oil contamination. It uses same components as PB112 valve, with excellent control in a wide flow and pressure range. The steel body is designed for heavy duty applications. Pressure setting at least 1.3 times the load induced pressure.

Dieses Ventil ist durch seine kompakten Maße und seine gute Toleranz bezüglich einer eventuellen Ölverschmutzung gekennzeichnet. Es besteht aus den gleichen Komponenten wie das Ventil PB112. Dank seines Stahlgehäuses ist dieses Ventil auch für schwere Anwendungen geeignet. Sehr gute Kontrolle innerhalb eines weiten Volumenstrom- und Druckbereiches. Druckeinstellung 1.3x Ladedruck.

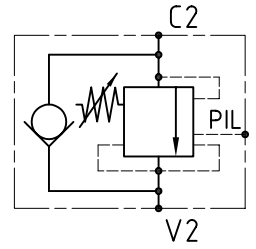

TECHNICAL DATA TECHNISCHE ANGABEN	
Max operating pressure Maximaler Betriebsdruck	21 MPa-2987 psi (Alloy/Aluminium) 35 MPa-5076 psi (Zincoated Steel/Verzink. Stahl)
Max flow Volumenstrom	60 l/min 15.9 gpm
Temperature range Betriebstemperatur	-20°/80°C
Filtration Filtergrad	40µ
Pilot ratio Versteuerverhältnis	4.25:1

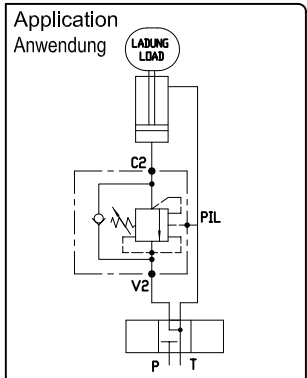
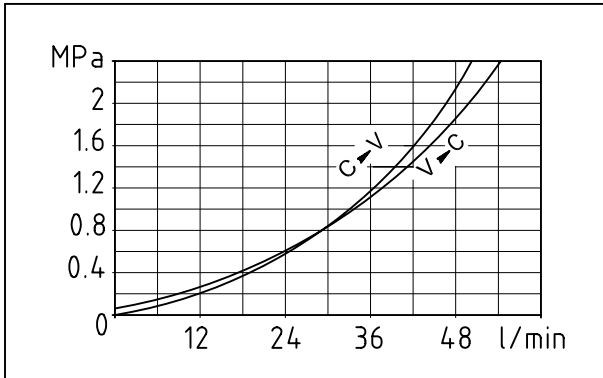
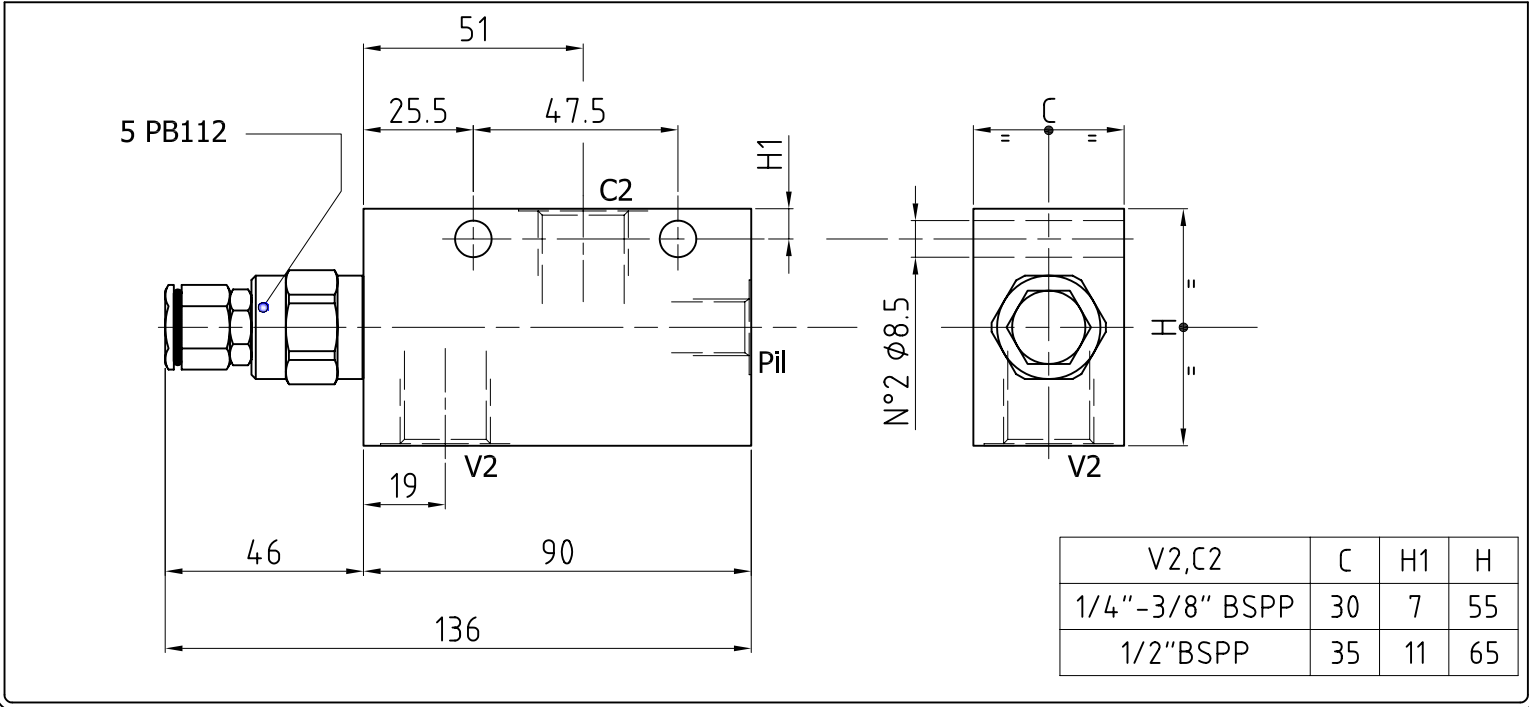
V2,C2	C	H1	H
1/4"-3/8" BSPP	30	7	55
1/2"BSPP	35	11	65

ORDERING INSTRUCTIONS - BESTELLEANLEITUNGEN

14 41 10 20 **X Y W**

Spring pressure range Feder-Einstellbereich	Pressure increase MPa/turn Drucksteigerung MPa je Schraubendrehung	Standard setting MPa Standard Einstellung MPa	X
6-21 MPa	5.6	20	1
10-35 MPa	10	35	2

W	Material Material	
0	Steel / Stahl	
1	Alloy / Aluminium	
Z	Thread - Gewinde V2, C2 Pil	
01	1/4" BSPP	1/4" BSPP
02	3/8" BSPP	
03	1/2" BSPP	

An overcenter valve with compact dimensions and good tolerance to oil contamination. It uses same components as PB012 valve, with excellent control in a wide flow and pressure range.

The steel body is designed for heavy duty applications.

Pressure setting at least 1.3 times the load induced pressure.

Dieses Ventil ist durch seine kompakten Maße und seine gute Toleranz bezüglich einer eventuellen Ölverschmutzung gekennzeichnet. Es besteht aus den gleichen Komponenten wie das Ventil PB012. Dank seines Stahlgehäuses ist dieses Ventil auch für schwere Anwendungen geeignet. Sehr gute Kontrolle innerhalb eines weiten Volumenstrom- und Druckbereiches.

Druckeinstellung 1.3x Ladedruck.

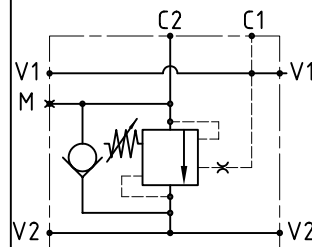
**TECHNICAL DATA
TECHNISCHE ANGABEN**

Max operating pressure Maximaler Betriebsdruck	21 MPa-2987 psi (Alloy/Aluminium) 35 MPa-5076 psi (Zincoated Steel/Verzinkt Stahl)
Max flow Volumenstrom	60 l/min 15.9 gpm
Temperature range Betriebstemperatur	-20°/80°C
Filtration Filtergrad	40µ
Pilot ratio Versteuerverhältnis	4.25:1

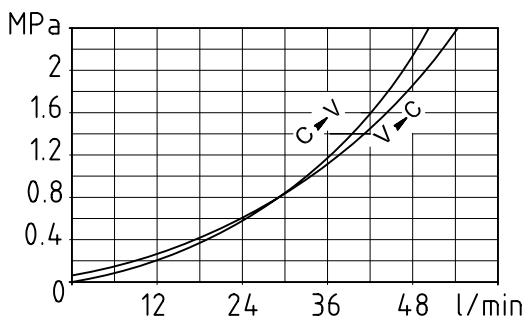
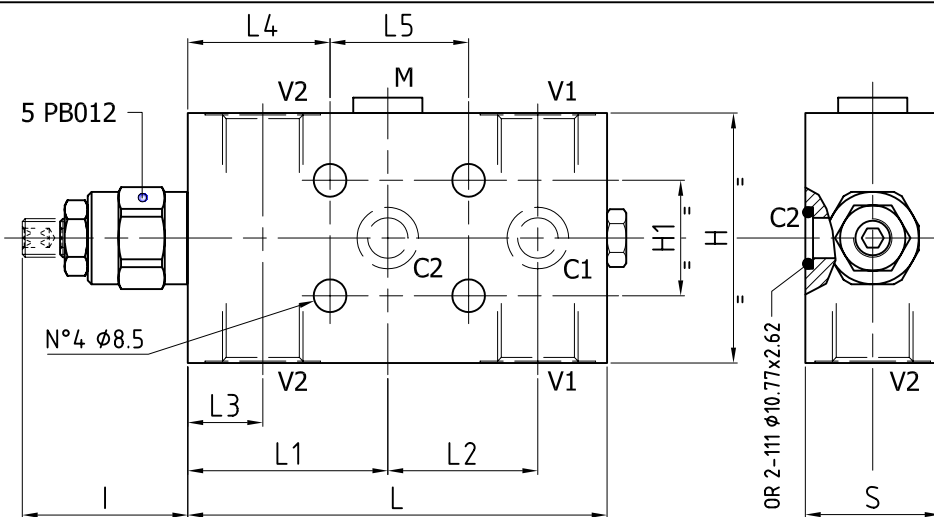
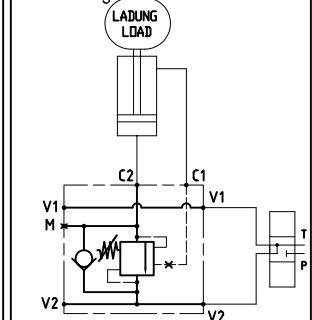
**Application
Anwendung**

Description	V2,C2	L	L1	L2	L3	L4	L5	I max	H	H1	S	F
VBG-SE-F1-30-PLR-14	1/4" BSPP	109	52	39	19.5	37	36	43.5	55	30	29.5	8.5
VBG-SE-F1-30-PLR-38	3/8" BSPP	109	52	39	19.5	37	36	43.5	55	30	29.5	8.5
VBG-SE-F1-30-PLR-12	1/2" BSPP	109	52	39	19.5	37	36	43.5	65	30	34.5	8.5

ORDERING INSTRUCTIONS - BESTELLANLEITUNGEN
14 41 37 10 X Y W

Spring pressure range Feder-Einstellbereich	Pressure increase MPa/turn Drucksteigerung MPa je Schraubendrehung	Standard setting MPa Standard Einstellung MPa	X
6-21 MPa	5.6	20	1
10-35 MPa	10	35	2

W	Material Material
0	Steel / Stahl
1	Alloy / Aluminium
Z	Thread - Gewinde V1, V2, C1,C2
01	1/4" BSPP
02	3/8" BSPP
03	1/2" BSPP

VBG-SE-F1-30-38-PLR

An overcenter valve with compact dimensions and good tolerance to oil contamination. It uses same components as PB012 valve, with excellent control in a wide flow and pressure range. The steel body is designed for heavy duty applications. Pressure setting at least 1.3 times the load induced pressure.

Dieses Ventil ist durch seine kompakten Maße und seine gute Toleranz bezüglich einer eventuellen Ölverschmutzung gekennzeichnet. Es besteht aus den gleichen Komponenten wie das Ventil PB012. Dank seines Stahlgehäuses ist dieses Ventil auch für schwere Anwendungen geeignet. Sehr gute Kontrolle innerhalb eines weiten Volumenstrom- und Druckbereiches. Druckeinstellung 1.3x Ladedruck.

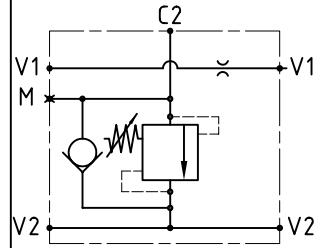

TECHNICAL DATA TECHNISCHE ANGABEN	
Max operating pressure Maximaler Betriebsdruck	21 MPa-2987 psi (Alloy/Aluminium) 35 MPa-5076 psi (Zincoated Steel/Verzink. Stahl)
Max flow Volumenstrom	60 l/min 15.9 gpm
Temperature range Betriebstemperatur	-20°/80°C
Filtration Filtergrad	40µ

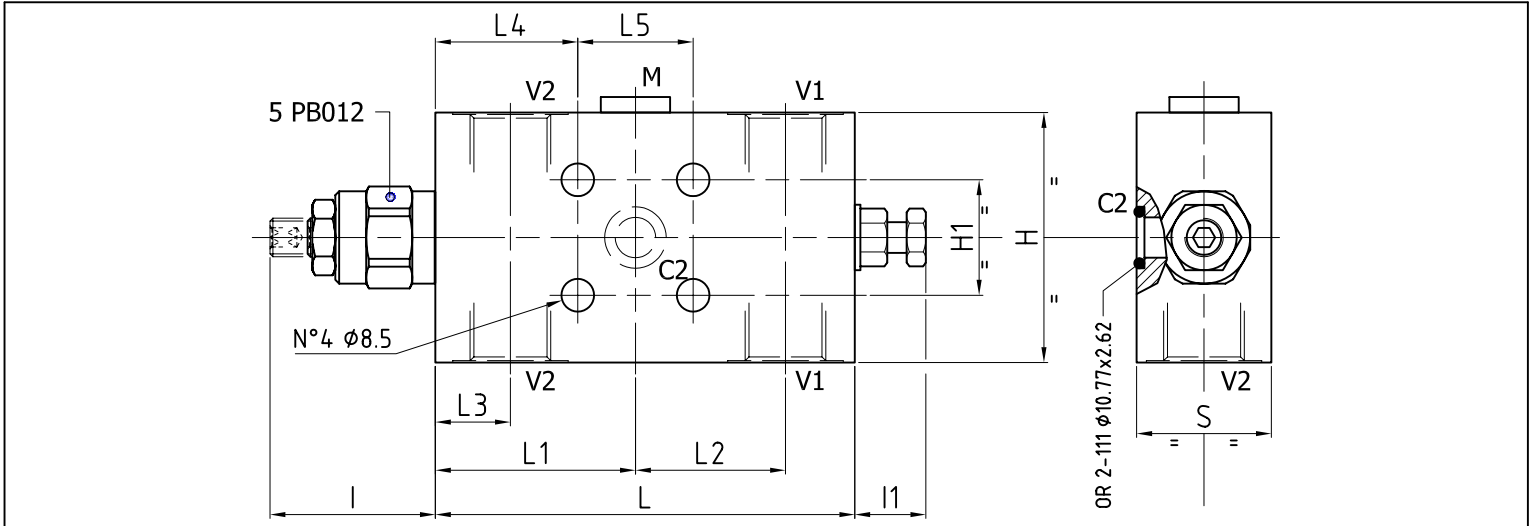
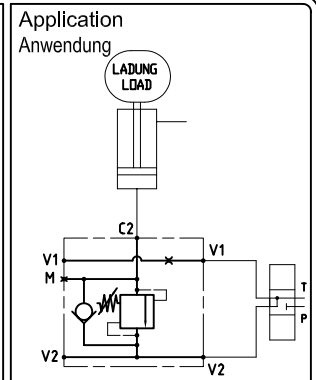
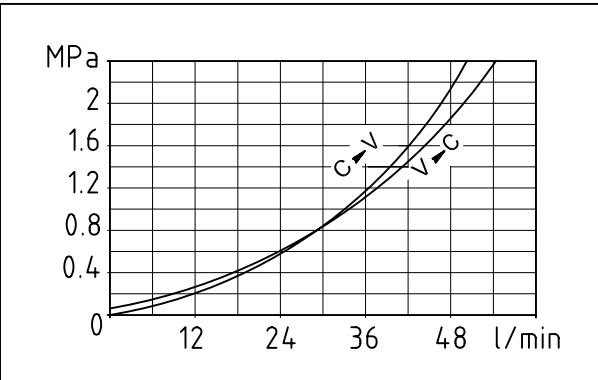

Description	V2,C2	L	L1	L2	L3	L4	L5	I max	I1 max	H	H1	S	Weigth-Gewicht	
													Alloy/Alumin.	Steel/Stahl
VBG-SE-F1-30-38-PLR-__01__	1/4" BSPP	109	52	39	19.5	37	30	43.5	18.5	55	30	29.5	0.65	1.5
VBG-SE-F1-30-38-PLR-__02__	3/8" BSPP	109	52	39	19.5	37	30	43.5	18.5	55	30	29.5	0.65	1.5
VBG-SE-F1-30-38-PLR-__03__	1/2" BSPP	109	52	39	19.5	37	30	43.5	18.5	65	30	34.5	0.8	1.9

ORDERING INSTRUCTIONS - BESTELLANLEITUNGEN

14 41 38 **X Y W Z**

Pilot ratio Versteuerverhältnis	X
4.25:1	10
2.7:1	11

Spring pressure range Feder-Einstellbereich	Pressure increase MPa/turn Drucksteigerung MPa je Schraubendrehung	Standard setting MPa Standard Einstellung MPa	Y
6-21 MPa	5.6	20	1
10-35 MPa	10	35	2

Z	Material Material
0	Steel / Stahl
1	Alloy / Aluminium

W	Thread - Gewinde V1, V2, C1,C2
01	1/4" BSPP
02	3/8" BSPP
03	1/2" BSPP

An overcenter valve with compact dimensions and good tolerance to oil contamination. It uses same components as PB012 valve, with excellent control in a wide flow and pressure range.

The steel body is designed for heavy duty applications.

Pressure setting at least 1.3 times the load induced pressure.

Dieses Ventil ist durch seine kompakten Maße und seine gute Toleranz bezüglich einer eventuellen Ölverschmutzung gekennzeichnet. Es besteht aus den gleichen Komponenten wie das Ventil PB012. Dank seines Stahlgehäuses ist dieses Ventil auch für schwere Anwendungen geeignet. Sehr gute Kontrolle innerhalb eines weiten Volumenstrom- und Druckbereiches.

Druckeinstellung 1.3x Ladedruck.

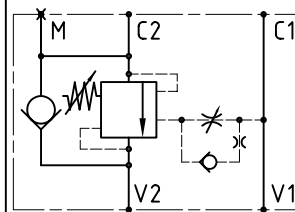
TECHNICAL DATA
TECHNISCHE ANGABEN

Max operating pressure Maximaler Betriebsdruck	21 MPa-2987 psi (Alloy/Aluminium) 35 MPa-5076 psi (Zincoated Steel/Verzink. Stahl)
Max flow Volumenstrom	60 l/min 15.9 gpm
Temperature range Betriebstemperatur	-20°/80°C
Filtration Filtergrad	40µ
Pilot ratio Verstellungsverhältnis	4.25:1

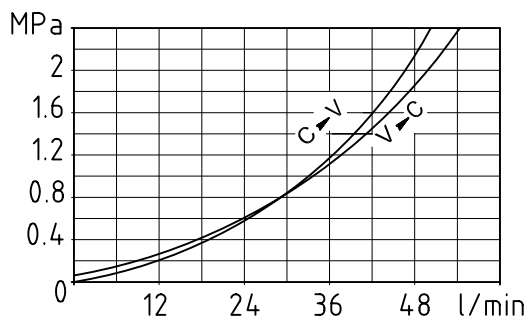
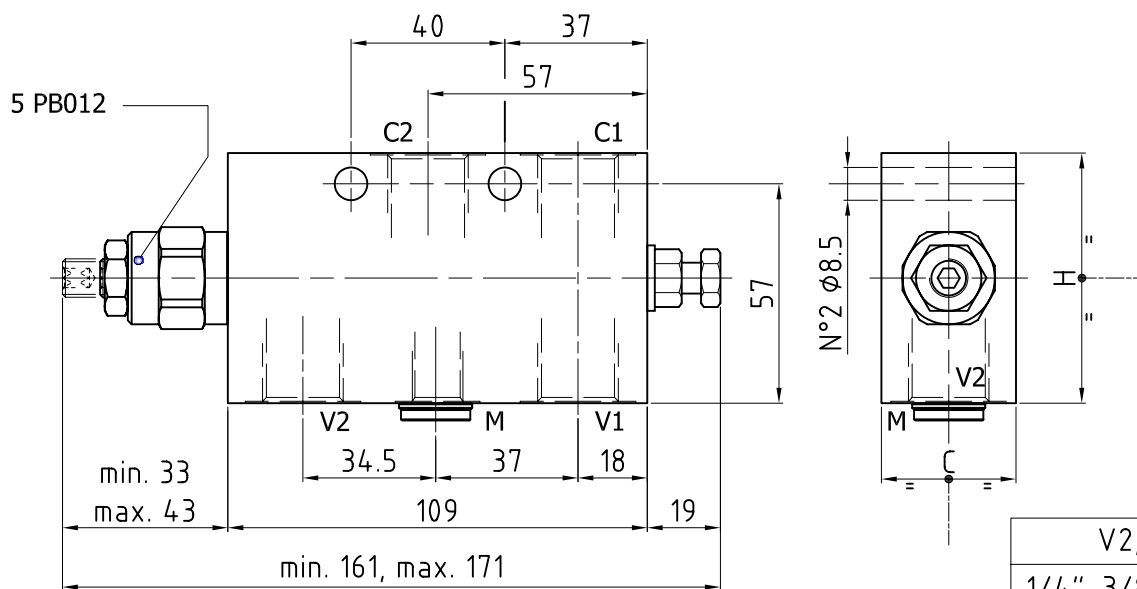
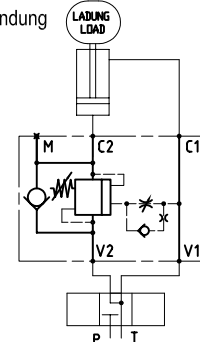
Application
Anwendung

V2,C2	C	H
1/4"-3/8" BSPP	30	55
1/2"BSPP	35	65

ORDERING INSTRUCTIONS - BESTELLANLEITUNGEN
14 41 11 10 X Y W

Spring pressure range Feder-Einstellbereich	Pressure increase MPa/turn Drucksteigerung MPa je Schraubendrehung	Standard setting MPa Standard Einstellung MPa	X
6-21 MPa	5.6	20	1
10-35 MPa	10	35	2

W	Material Material
0	Steel / Stahl
1	Alloy / Aluminium
Z	Thread - Gewinde V1, V2, C1,C2
01	1/4" BSPP
02	3/8" BSPP
03	1/2" BSPP

An overcenter valve with compact dimensions and good tolerance to oil contamination. It uses same components as PB033 valve, with excellent control in a wide flow and pressure range. The steel body is designed for heavy duty applications. Pressure setting at least 1.3 times the load induced pressure.

Dieses Ventil ist durch seine kompakten Maße und seine gute Toleranz bezüglich einer eventuellen Ölverschmutzung gekennzeichnet. Es besteht aus den gleichen Komponenten wie das Ventil PB033. Dank seines Stahlgehäuses ist dieses Ventil auch für schwere Anwendungen geeignet. Sehr gute Kontrolle innerhalb eines weiten Volumenstrom- und Druckbereiches. Druckeinstellung 1.3x Ladedruck.

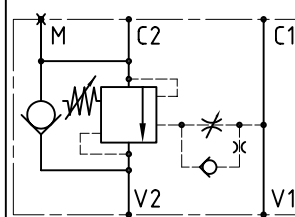
TECHNICAL DATA
TECHNISCHE ANGABEN

Max operating pressure Maximaler Betriebsdruck	21 MPa-2987 psi (Alloy/Aluminium) 35 MPa-5076 psi (Zincoated Steel/Verzinkt. Stahl)
Max flow Volumenstrom	150 l/min 39.6 gpm
Temperature range Betriebstemperatur	-20°/80°C
Filtration Filtergrad	40µ

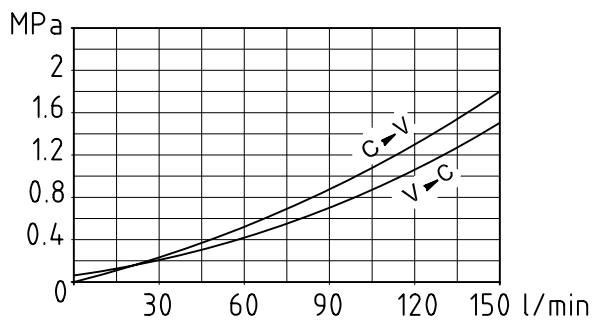
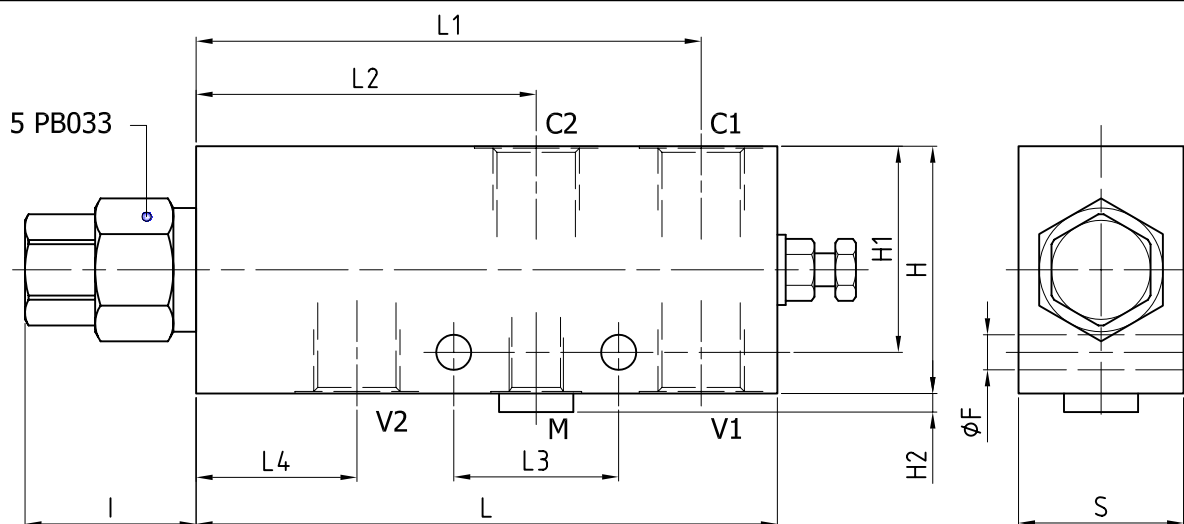
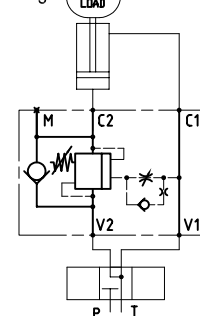
Application
Anwendung

Description	V2,C2	L	L1	L2	L3	L4	H	H1	H2	S	F
VBG-SE-33-PLR-12	1/2" BSPP	141	122.5	82.5	40	39	60	50	4	40	8.5
VBG-SE-33-PLR-34	3/4" BSPP	147	126	83	40	40	80	60	4	40	8.5

ORDERING INSTRUCTIONS - BESTELLANLEITUNGEN
14 41 35 3 X Y W Z

Pilot ratio Versteuerverhältnis	X
4:1	4
8:1	8

Z	Material Material
0	Steel / Stahl
1	Alloy / Aluminium

Spring pressure range Feder-Einstellbereich	Pressure increase MPa/turn Drucksteigerung MPa je Schraubendrehung	Standard setting MPa Standard Einstellung MPa	Y
10-35 MPa	10	35	2

W	Thread - Gewinde V1, V2, C1,C2	M
03	1/2" BSPP	1/4" BSPP
04	3/4" BSPP	1/4" BSPP

An overcenter valve with compact dimensions and good tolerance to oil contamination. It uses same components as PB133 valve, with excellent control in a wide flow and pressure range. The steel body is designed for heavy duty applications. Pressure setting at least 1.3 times the load induced pressure.

Dieses Ventil ist durch seine kompakten Maße und seine gute Toleranz bezüglich einer eventuellen Ölverschmutzung gekennzeichnet. Es besteht aus den gleichen Komponenten wie das Ventil PB133. Dank seines Stahlgehäuses ist dieses Ventil auch für schwere Anwendungen geeignet. Sehr gute Kontrolle innerhalb eines weiten Volumenstrom- und Druckbereiches. Druckeinstellung 1.3x Ladedruck.

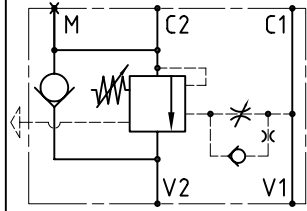

TECHNICAL DATA TECHNISCHE ANGABEN	
Max operating pressure Maximaler Betriebsdruck	21 MPa-2987 psi (Alloy/Aluminium) 35 MPa-5076 psi (Zincoated Steel/Verzink. Stahl)
Max flow Volumenstrom	150 l/min 39.6 gpm
Temperature range Betriebstemperatur	-20°/80°C
Filtration Filtergrad	40µ

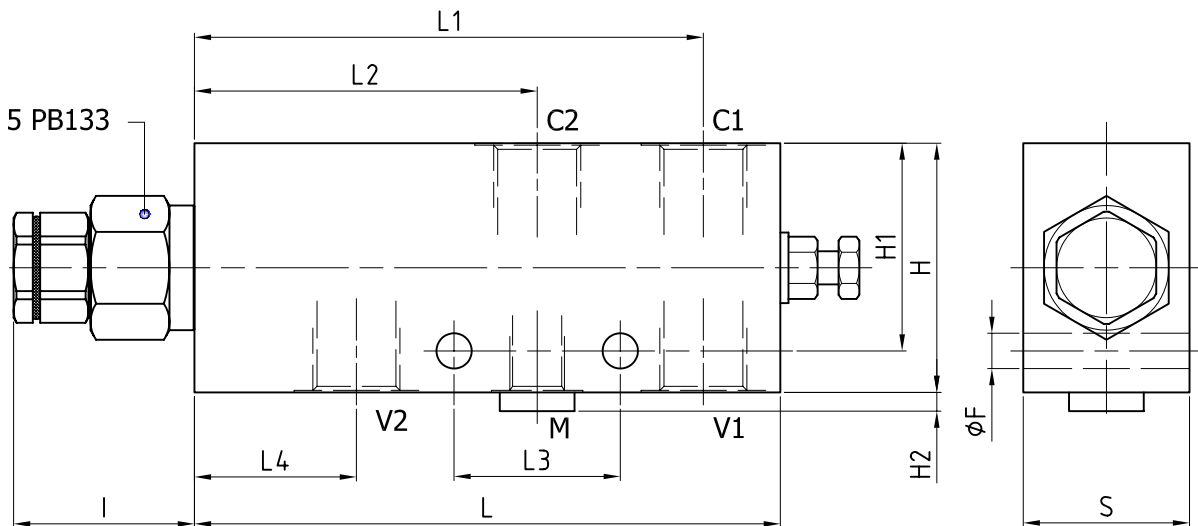
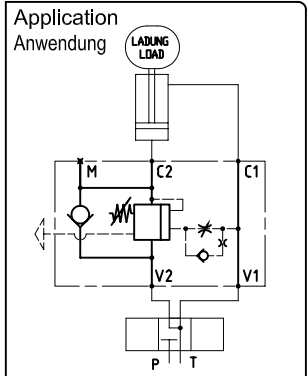
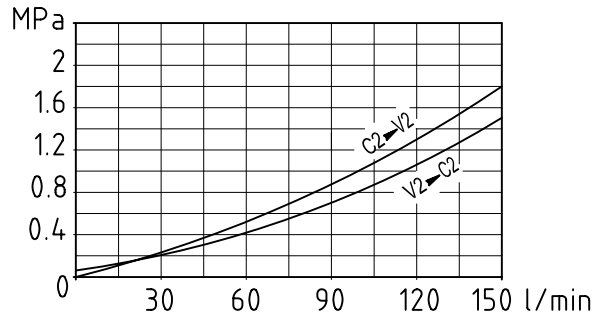

Description	V2,C2	L	L1	L2	L3	L4	H	H1	H2	S	F
VBG-SE-33-I-PLR-12	1/2" BSPP	141	122.5	82.5	40	39	60	50	4	40	8.5
VBG-SE-33-I-PLR-34	3/4" BSPP	147	126	83	40	40	80	60	4	40	8.5

ORDERING INSTRUCTIONS - BESTELLANLEITUNGEN

14 41 34 3 **X Y W Z**

Pilot ratio Versteuerverhältnis	X
4:1	4
8:1	8

Z	Material Material	Weight/Gewicht	
		1/2" BSPP	3/4" BSPP
0	Steel / Stahl	2.7 kg	3.7 kg
1	Alloy / Aluminium	1.0 kg	1.4 kg

Spring pressure range Feder-Einstellbereich	Pressure increase MPa/turn Drucksteigerung MPa je Schraubendrehung	Standard setting MPa Standard Einstellung MPa	Y
10-35 MPa	10	35	2

W	Thread - Gewinde V1, V2, C1,C2	
		M
03	1/2" BSPP	1/4" BSPP
04	3/4" BSPP	

An overcenter valve with compact dimensions and good tolerance to oil contamination. It uses same components as PB033 valve, with excellent control in a wide flow and pressure range. The steel body is designed for heavy duty applications. Pressure setting at least 1.3 times the load induced pressure.

Dieses Ventil ist durch seine kompakten Maße und seine gute Toleranz bezüglich einer eventuellen Ölverschmutzung gekennzeichnet. Es besteht aus den gleichen Komponenten wie das Ventil PB033. Dank seines Stahlgehäuses ist dieses Ventil auch für schwere Anwendungen geeignet. Sehr gute Kontrolle innerhalb eines weiten Volumenstrom- und Druckbereiches. Druckeinstellung 1.3x Ladedruck.

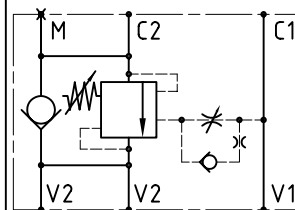
TECHNICAL DATA
TECHNISCHE ANGABEN

Max operating pressure Maximaler Betriebsdruck	21 MPa-2987 psi (Alloy/Aluminium) 35 MPa-5076 psi (Zincoated Steel/Verzink. Stahl)
Max flow Volumenstrom	150 l/min 39.6 gpm
Temperature range Betriebstemperatur	-40°/80°C
Filtration Filtergrad	40µ

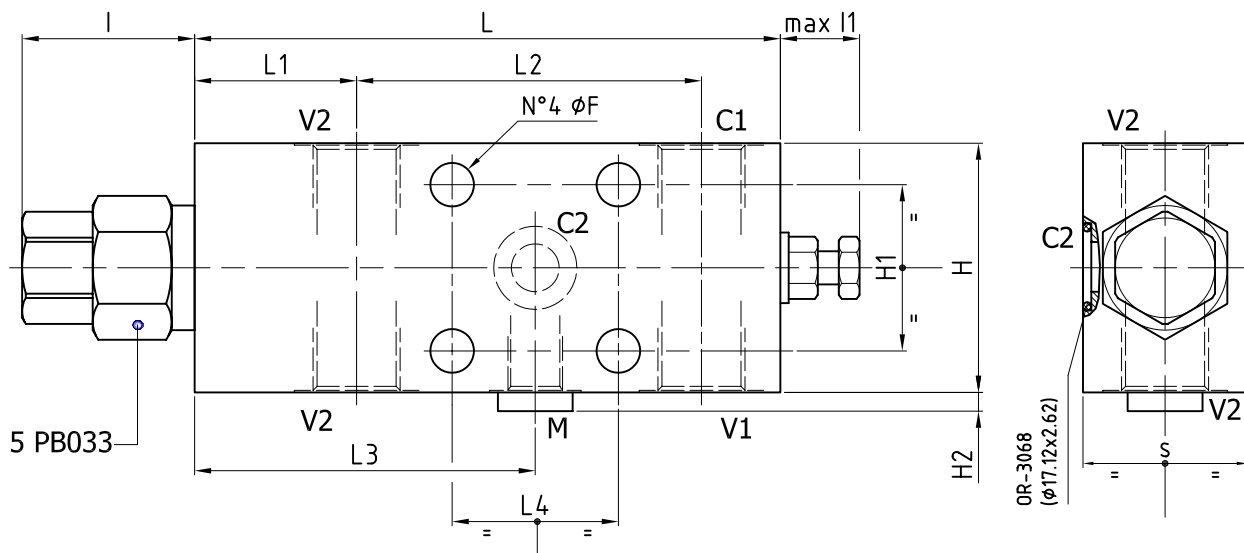
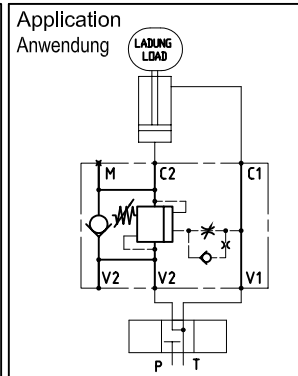
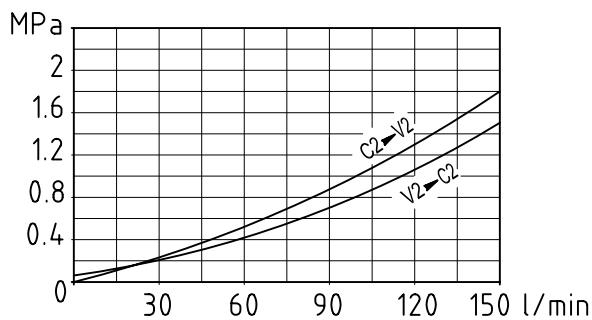

Description	V1, V2, C1	C2	L	L1	L2	L3	L4	I	I1	H	H1	H2	S	F	Weight-Gewicht	
															Alloy/Alumin.	Steel/Stahl
VBG-SE-F1-33-PLR-12	1/2" BSPP	φ12	141	39	83	82	40	41.5	19	60	40	4	39.5	10.5	1 kg	2.6 kg
VBG-SE-F1-33-PLR-34	3/4" BSPP	φ12	147	39	86	82	40	41.5	19	80	40	4	39.5	10.5	1.3 kg	3.6 kg

ORDERING INSTRUCTIONS - BESTELLANLEITUNGEN
14 41 36 3 X Y W Z

Pilot ratio Versteuerverhältnis	X
4:1	4
8:1	8

Z	Material Material
0	Steel / Stahl
1	Alloy / Aluminium

Spring pressure range Feder-Einstellbereich	Pressure increase MPa/turn Drucksteigerung MPa je Schraubendrehung	Standard setting MPa Standard Einstellung MPa	Y
10-35 MPa	10	35	2

W	Thread - Gewinde V1, V2, C1, C2	M
03	1/2" BSPP	1/4" BSPP
04	3/4" BSPP	

An overcenter valve with compact dimensions and good tolerance to oil contamination. It uses same components as PB133 valve, with excellent control in a wide flow and pressure range. The steel body is designed for heavy duty applications. Pressure setting at least 1.3 times the load induced pressure.

Dieses Ventil ist durch seine kompakten Maße und seine gute Toleranz bezüglich einer eventuellen Ölverschmutzung gekennzeichnet. Es besteht aus den gleichen Komponenten wie das Ventil PB133. Dank seines Stahlgehäuses ist dieses Ventil auch für schwere Anwendungen geeignet. Sehr gute Kontrolle innerhalb eines weiten Volumenstrom- und Druckbereiches. Druckeinstellung 1.3x Ladedruck.

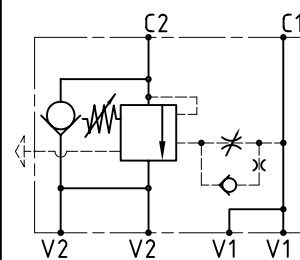
TECHNICAL DATA
TECHNISCHE ANGABEN

Max operating pressure Maximaler Betriebsdruck	21 MPa-2987 psi (Alloy/Aluminium) 35 MPa-5076 psi (Zincoated Steel/Verzink. Stahl)
Max flow Volumenstrom	150 l/min 39.6 gpm
Temperature range Betriebstemperatur	-20°/80°C
Filtration Filtergrad	40µ
Pilot ratio Versteuerverhältnis	4:1

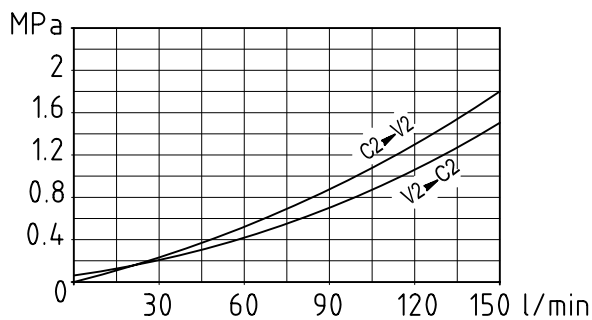
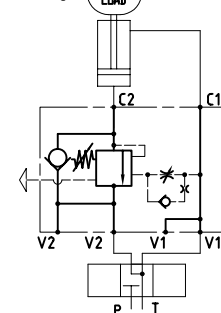
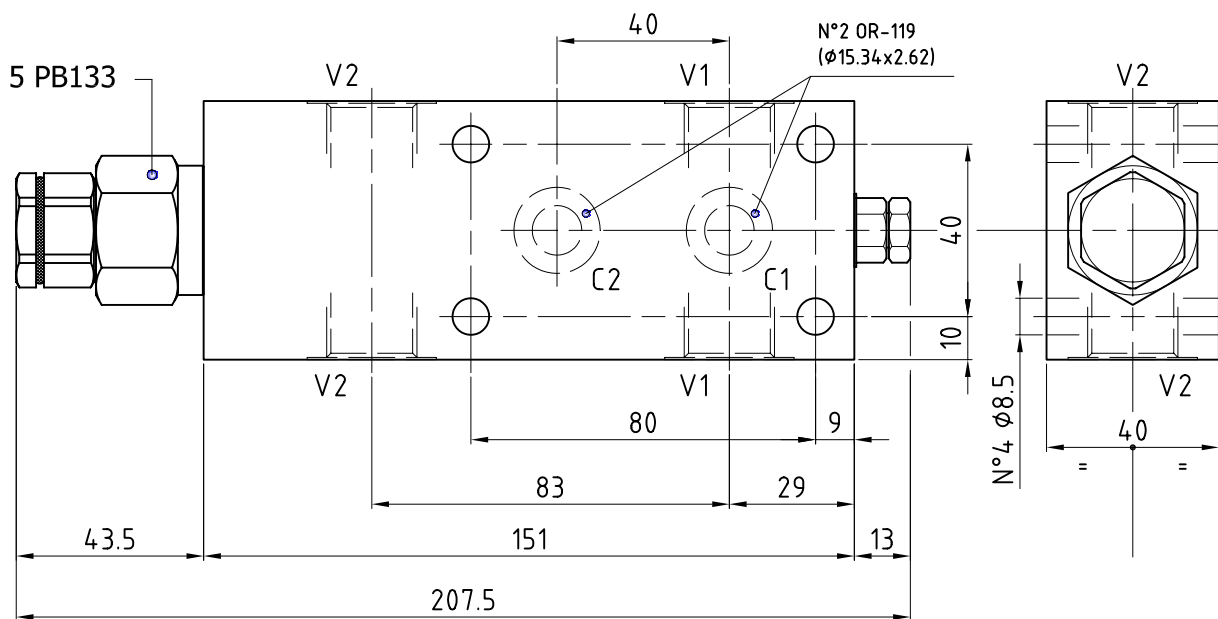
Application
Anwendung

ORDERING INSTRUCTIONS - BESTELLANLEITUNGEN
14 41 42 44 Y W Z

Spring pressure range Feder-Einstellbereich	Pressure increase MPa/turn Drucksteigerung MPa je Schraubendrehung	Standard setting MPa Standard Einstellung MPa	Y
10-35 MPa	10	35	2

Z	Material Material
0	Steel / Stahl
1	Alloy / Aluminium

W	Thread - Gewinde V1, V2
03	1/2" BSPP

VBG-SE-F1-33-43-I-PLR

An overcenter valve with compact dimensions and good tolerance to oil contamination. It uses same components as PB033 valve, with excellent control in a wide flow and pressure range. The steel body is designed for heavy duty applications. Pressure setting at least 1.3 times the load induced pressure.

Dieses Ventil ist durch seine kompakten Maße und seine gute Toleranz bezüglich einer eventuellen Ölverschmutzung gekennzeichnet. Es besteht aus den gleichen Komponenten wie das Ventil PB033. Dank seines Stahlgehäuses ist dieses Ventil auch für schwere Anwendungen geeignet. Sehr gute Kontrolle innerhalb eines weiten Volumenstrom- und Druckbereiches. Druckeinstellung 1.3x Ladedruck.

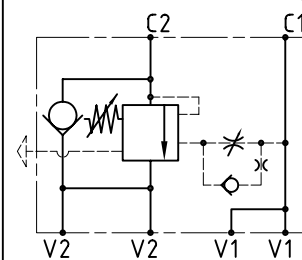

TECHNICAL DATA TECHNISCHE ANGABEN

Max operating pressure Maximaler Betriebsdruck	21 MPa-2987 psi (Alloy/Aluminium) 35 MPa-5076 psi (Zincoated Steel/Verzink. Stahl)
Max flow Volumenstrom	150 l/min 39.6 gpm
Temperature range Betriebstemperatur	-20°/80°C
Filtration Filtergrad	40µ
Pilot ratio Versteuerverhältnis	4:1

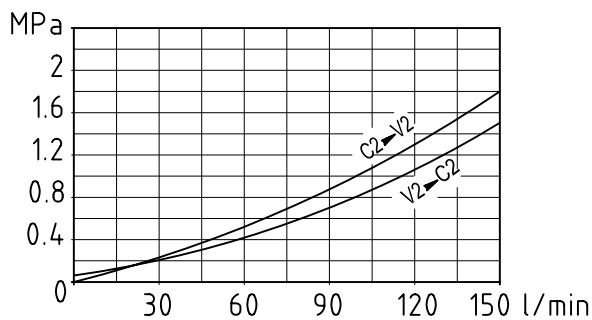

Application Anwendung

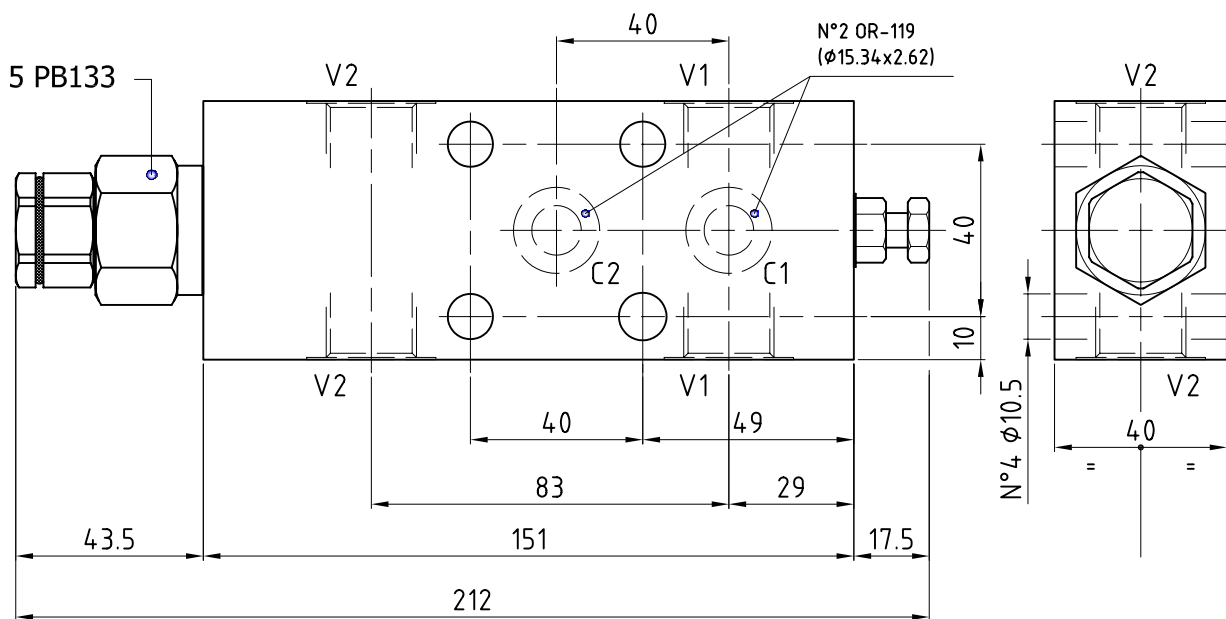
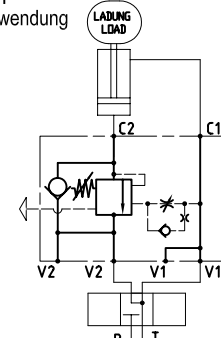

ORDERING INSTRUCTIONS - BESTELLANLEITUNGEN

14 41 43 44 **Y W Z**

Spring pressure range Feder-Einstellbereich	Pressure increase MPa/turn Drucksteigerung MPa je Schraubendrehung	Standard setting MPa Standard Einstellung MPa	Y
10-35 MPa	10	35	2

Z	Material Material
0	Steel / Stahl
1	Alloy / Aluminium

W	Thread - Gewinde V1, V2
03	1/2" BSPP

An overcenter valve with compact dimensions and good tolerance to oil contamination. The body is designed for heavy duty applications. Pressure setting at least 1.3 times the load induced pressure.

Dieses Ventil ist durch seine kompakten Maße und seine gute Toleranz bezüglich einer eventuellen Ölverschmutzung gekennzeichnet. Dank seines Gehäuses ist dieses Ventil auch für schwere Anwendungen geeignet. Sehr gute Kontrolle innerhalb eines weiten Volumenstrom- und Druckbereiches. Druckeinstellung 1.3x Ladedruck.

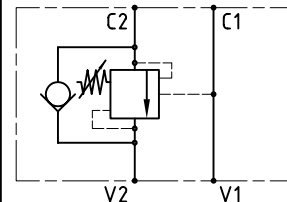
**TECHNICAL DATA
TECHNISCHE ANGABEN**

Max operating pressure Maximaler Betriebsdruck	21 MPa-2987 psi (Alloy/Aluminium) 35 MPa-5076 psi (Zincoated Steel/Verzink. Stahl)
Max flow Volumenstrom	see performance graph siehe Diagramm
Temperature range Betriebstemperatur	-20°/80°C
Filtration Filtergrad	40µ

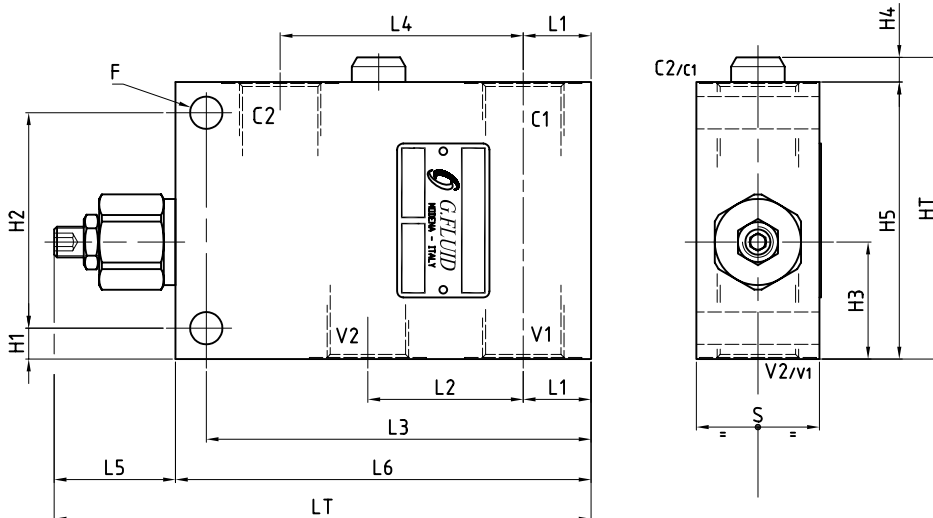
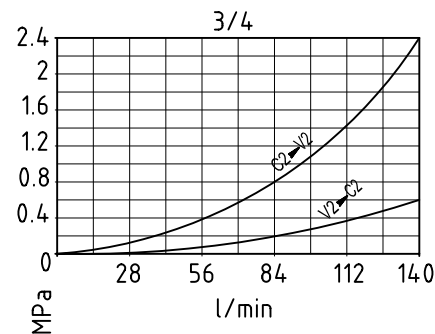
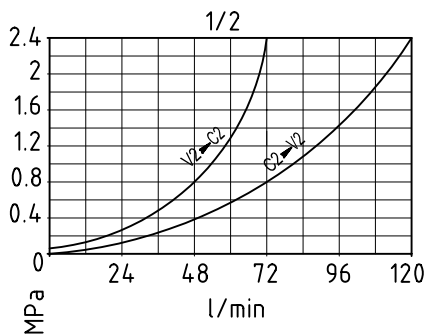

V1,V2,C1, C2	F	L1	L2	L3	L4	L5	L6	LT	H1	H2	H3	H4	H5	HT	S	Weight/Gewicht Alloy/Alumin. - Steel/Stahl	
1/2" BSPP	8.5	18	36.5	103	62.5	39.5	113	152.5	8	54	32	7	70	77	35	0.9	2.3
3/4" BSPP	10.5	22	50.5	125	79	39.5	135	174.5	10	70	38	8	90	98	40	1.5	3.9

ORDERING INSTRUCTIONS - BESTELLANLEITUNGEN
14 41 40 X Y W Z

Pilot ratio Steuerverhältnis	X
3.2:1	30
8.2:1	33

Z	Material Material
0	Steel / Stahl
1	Alloy / Aluminium

Spring pressure range Feder-Einstellbereich	Pressure increase MPa/turn Drucksteigerung MPa je Schraubendrehung	Standard setting MPa Standard Einstellung MPa	Y
3-12 MPa	1.6	10	1
8-35 MPa	4.4	35	2

W	Thread - Gewinde V1, V2, C1,C2
03	1/2" BSPP
04	3/4" BSPP

An overcenter valve with compact dimensions and good tolerance to oil contamination. The body is designed for heavy duty applications. Pressure setting at least 1.3 times the load induced pressure.

Dieses Ventil ist durch seine kompakten Maße und seine gute Toleranz bezüglich einer eventuellen Ölverschmutzung gekennzeichnet. Dank seines Gehäuses ist dieses Ventil auch für schwere Anwendungen geeignet. Sehr gute Kontrolle innerhalb eines weiten Volumenstrom- und Druckbereiches. Druckeinstellung 1.3x Ladedruck.

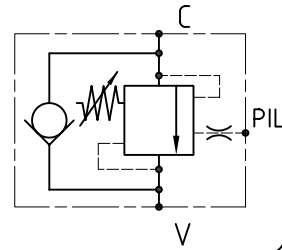
TECHNICAL DATA
TECHNISCHE ANGABEN

Max operating pressure Maximaler Betriebsdruck	21 MPa-2987 psi (Alloy/Aluminium) 35 MPa-5076 psi (Zinc coated Steel/Verzinkt Stahl)
Max flow Volumenstrom	see performance graph siehe Diagramm
Temperature range Betriebstemperatur	-20°/80°C
Filtration Filtergrad	40µ

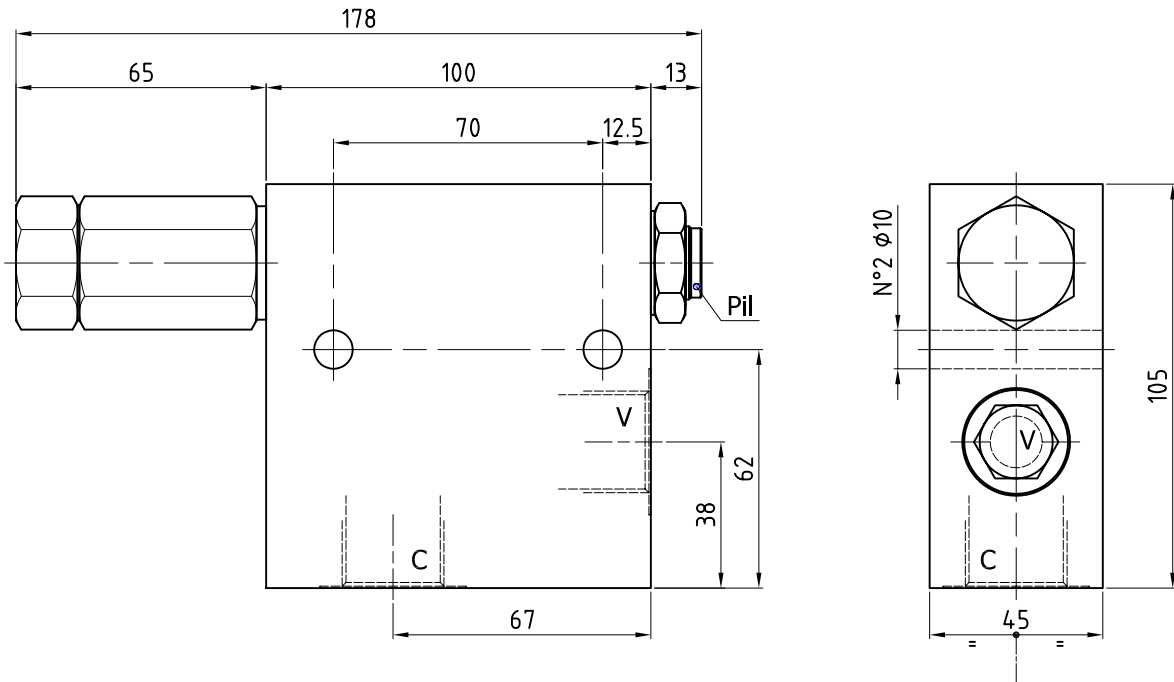
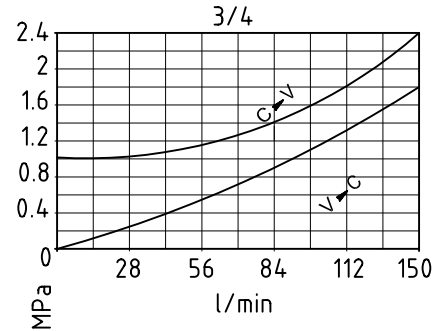
ORDERING INSTRUCTIONS - BESTELLANLEITUNGEN
14 41 41 X Y W Z

Pilot ratio Steuerverhältnis	X
7.6:1	60

Z	Material Material
0	Steel / Stahl
1	Alloy / Aluminium

Spring pressure range Feder-Einstellbereich	Pressure increase MPa/turn Drucksteigerung MPa je Schraubendrehung	Standard setting MPa Standard Einstellung MPa	Y
7-21 MPa	1.6	20	1
13-35 MPa	4.4	35	2

W	Thread - Gewinde V, C Pil
04	3/4" BSPP 1/4" BSPP

An overcenter valve with compact dimensions and good tolerance to oil contamination. The body is designed for heavy duty applications. Pressure setting at least 1.3 times the load induced pressure.

Dieses Ventil ist durch seine kompakten Maße und seine gute Toleranz bezüglich einer eventuellen Ölverschmutzung gekennzeichnet. Dank seines Gehäuses ist dieses Ventil auch für schwere Anwendungen geeignet. Sehr gute Kontrolle innerhalb eines weiten Volumenstrom- und Druckbereiches. Druckeinstellung 1.3x Ladedruck.

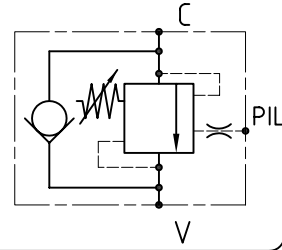
TECHNICAL DATA
TECHNISCHE ANGABEN

Max operating pressure Maximaler Betriebsdruck	21 MPa-2987 psi (Alloy/Aluminium) 35 MPa-5076 psi (Zincoated Steel/Verzink. Stahl)
Max flow Volumenstrom	see performance graph siehe Diagramm
Temperature range Betriebstemperatur	-20°/80°C
Filtration Filtergrad	40µ
Pilot ratio Versteuerverhältnis	3.1:1

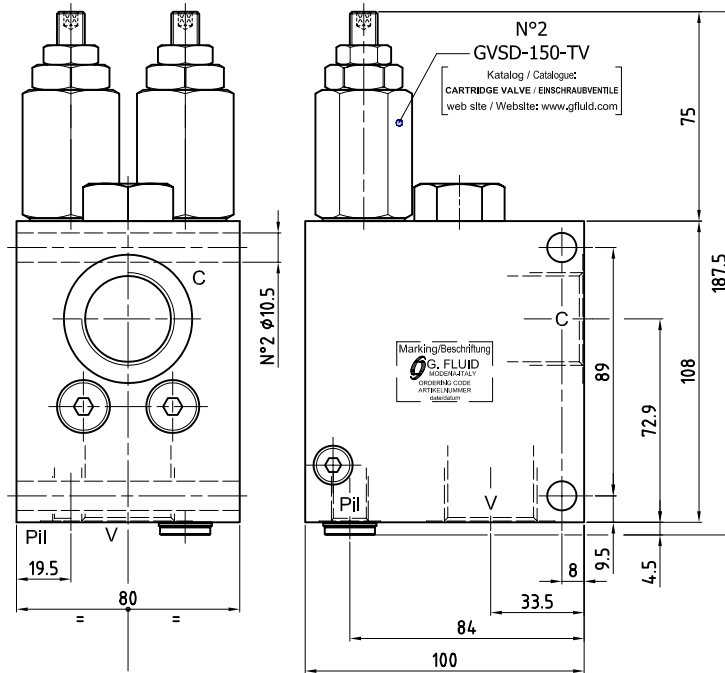
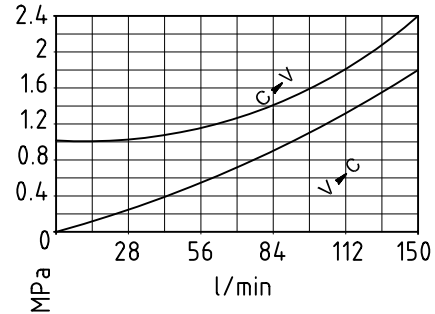

ORDERING CODE - ARTIKELNUMMER
14413961

	Adj. range Regelbereich	std setting Standardeinst.	Pressure increase MPa/turn Drucksteigerung MPa je Schraubendrehung	Port size/Gewinde V, C Pil	Material Material	Weigth Gewicht	Description Bezeichnung
1	7-21 MPa	20 MPa	6.5	05 G 1" / G 1/4"	0 Alloy/Aluminium	2.5 kg	VBG-SE-150-39-A
2	10-35 MPa	35 MPa	6.5		1 Zincoated Steel/ Verzinkter Stahl	6.8 kg	VBG-SE-150-39-S

VBG-SE-71

An overcenter valve with compact dimensions and good tolerance to oil contamination. The steel body is designed for heavy duty applications. Pressure setting at least 1.3 times the load induced pressure.

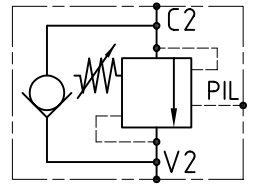
Dieses Ventil ist durch seine kompakten Maße und seine gute Toleranz bezüglich einer eventuellen Ölverschmutzung gekennzeichnet. Dank seines Stahlgehäuses ist dieses Ventil auch für schwere Anwendungen geeignet. Sehr gute Kontrolle innerhalb eines weiten Volumenstrom- und Druckbereiches. Druckeinstellung 1.3x Ladedruck.



TECHNICAL DATA TECHNISCHE ANGABEN	
Max operating pressure Maximaler Betriebsdruck	21 MPa-2987 psi (Alloy/Aluminium) 35 MPa-5076 psi (Zincoated Steel/Verzink. Stahl)
Max flow Volumenstrom	see performance graph siehe Diagramm
Temperature range Betriebstemperatur	-20°/80°C
Filtration Filtergrad	40µ

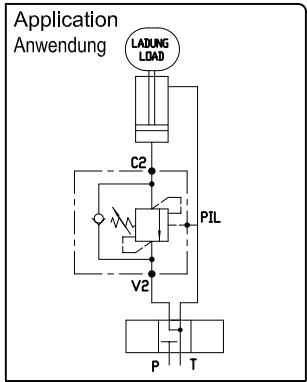
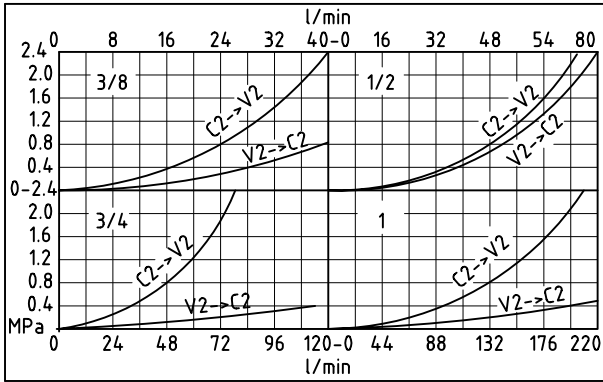

V2, C2	L	L1	L2	L3	L4	L5	L6	H	H1	H2	H3	H4	H5	S	F	Weight/Gewicht (kg)	
																Alloy/Alum.	Zinc. Steel/Verzink. Stahl
1"G	160	35	77	40.5	45	9	214	100	10	55	35	19.5	119.5	50	10.5	3.2	8.9
3/4"G	127	29	62	42.5	70	9	206	90	10	50	35	4.5	94.5	40	10.5	1.7	4.7
1/2"G	115	27.5	53.5	37.5	72	9	196	70	8	48	30	8	78	40	8.5	1.3	3.6
3/8"G	100	27.5	48.5	27.5	74	9	183	65	8	40	26.5	10	75	35	8.5	0.9	2.2

ORDERING CODE - ARTIKELNUMMER

144171 00

91	Pilot ratio Steuerverhältnis	7.6:1 8:1	V2/C2 (G)	1/2" - 3/4" 1"	1	Adj. range Regelbereich	6-21 MPa 2-12 MPa	std setting Standardeinst.	20 MPa 10 MPa	Pressure increase MPa/turn Drucksteigerung MPa je Schraubendrehung	6.5 1.0	V2/C2 (G)	3/8" - 1/2" - 3/4" 1"	02 03 04 05	Port size/Gewinde V2, C2	G 3/8" G 1/2" G 3/4" G 1"	Pil	G 1/4"	0 1	Material Material	Alloy/Aluminium Zincoated Steel/ Verzinkter Stahl
	92	Pilot ratio Steuerverhältnis	3.6:1 3:1 2.8:1	V2/C2 (G)		3/8" 1/2" - 3/4" 1"	2	Adj. range Regelbereich	10-35 MPa	std setting Standardeinst.	35 MPa	Pressure increase MPa/turn Drucksteigerung MPa je Schraubendrehung	7.5 4.4		V2/C2 (G)	3/8" - 1/2" - 3/4" 1"		Port size/Gewinde V2, C2		G 3/8" G 1/2" G 3/4" G 1"	Pil

VBG-SE-72

An overcenter valve with compact dimensions and good tolerance to oil contamination. The steel body is designed for heavy duty applications. Pressure setting at least 1.3 times the load induced pressure.

Dieses Ventil ist durch seine kompakten Maße und seine gute Toleranz bezüglich einer eventuellen Ölverschmutzung gekennzeichnet. Dank seines Stahlgehäuses ist dieses Ventil auch für schwere Anwendungen geeignet. Sehr gute Kontrolle innerhalb eines weiten Volumenstrom- und Druckbereiches. Druckeinstellung 1.3x Ladedruck.

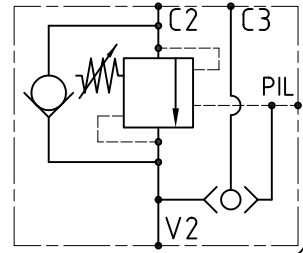

TECHNICAL DATA TECHNISCHE ANGABEN	
Max operating pressure Maximaler Betriebsdruck	21 MPa-2987 psi (Alloy/Aluminium) 35 MPa-5076 psi (Zincoated Steel/Verzink. Stahl)
Max flow Volumenstrom	see performance graph siehe Diagramm
Temperature range Betriebstemperatur	-20°/80°C
Filtration Filtergrad	40µ

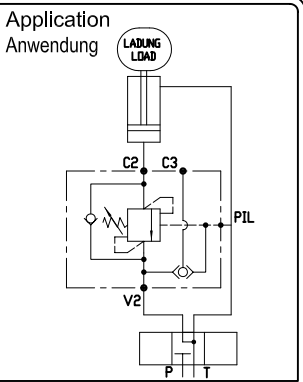
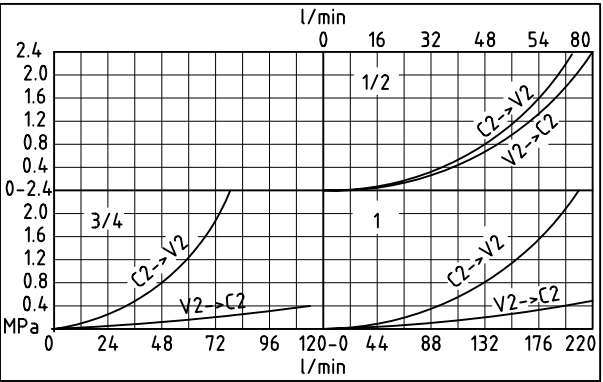

Marking/Beschriftung
G. FLUID
 MODERN-ITALY
 ORDERING CODE
 ARTIKELNUMMER
 14417200

V2, C2	L	L1	L2	L3	L4	L5	L6	L7	L8	H	H1	H2	H3	H4	S	S1	S2	F	Weight/Gewicht (kg)	
																			Alloy/Alum.	Zinc. Steel/Verzink. Stahl
1"G	160	35	77	116	35	85	45	9	214	100	10	35	2.5	102.5	70	30	14	10.5	4.0	11.1
3/4"G	127	29	62	78.5	10	75	70	9	206	90	10	35	4.5	94.5	60	20	15	10.5	2.3	6.4
1/2"G	115	27.5	53.5	71.5	10	67.5	72	9	196	70	8	30	8	78	55	20	12	8.5	1.6	4.6

ORDERING CODE - ARTIKELNUMMER

144172 00

Pilot ratio Steuerverhältnis	V2/C2 (G)
91 7.6:1	1/2" - 3/4"
8:1	1"
92 3:1	1/2" - 3/4"
2.8:1	1"

Adj. range Regelbereich	std setting Standardeinst.	Pressure increase MPa/turn Drucksteigerung MPa je Schraubendrehung	V2/C2 (G)
1 6-21 MPa	20 MPa	6.5	1/2" - 3/4"
2-12 MPa	10 MPa	1.0	1"
2 10-35 MPa	35 MPa	7.5	1/2" - 3/4"
		4.4	1"

Port size/Gewinde	
V2, C2	Pil, C3
03 G 1/2"	
04 G 3/4"	G 1/4"
05 G 1"	

Material	
Material	
0 Alloy/Aluminium	
1 Zincoated Steel/ Verzinkter Stahl	

VBG-SE-100

TECHNICAL DATA TECHNISCHE ANGABEN

Max operating pressure Maximaler Betriebsdruck	35 MPa 5076 psi
Max flow Volumenstrom	100 l/min 26.4 gpm
Weight Gewicht	2.7 kg
Material Material	Zinc coated steel Verzinkter Stahl
Pilot ratio Steuerverhältnis	4.2:1

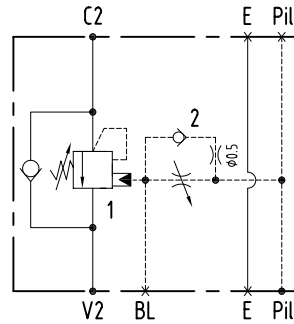

Diagram/Diagramm

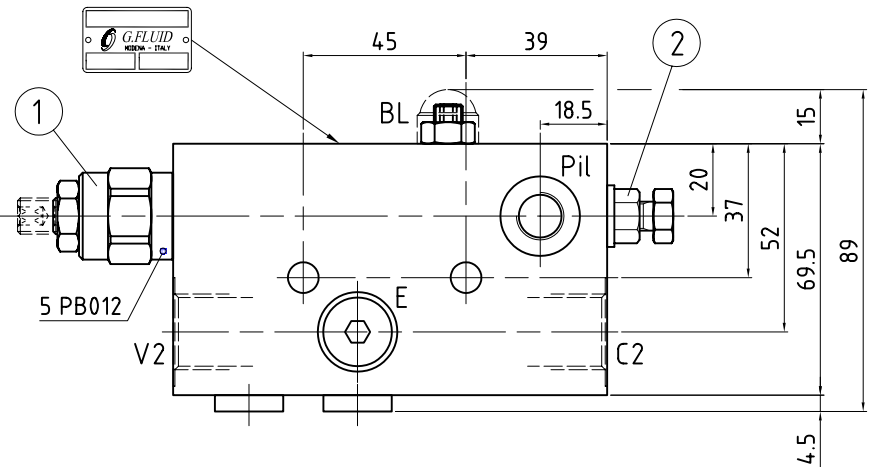
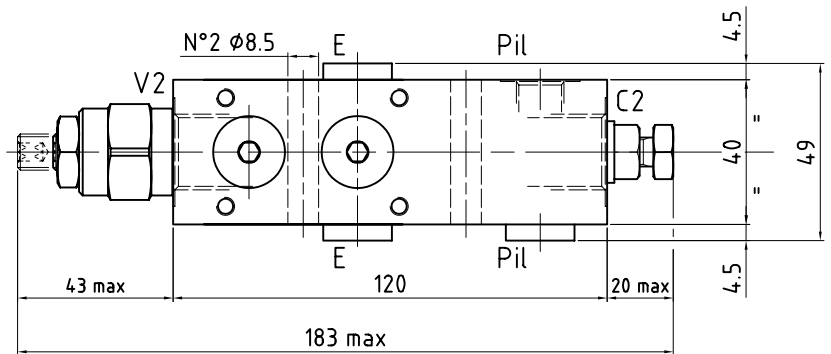
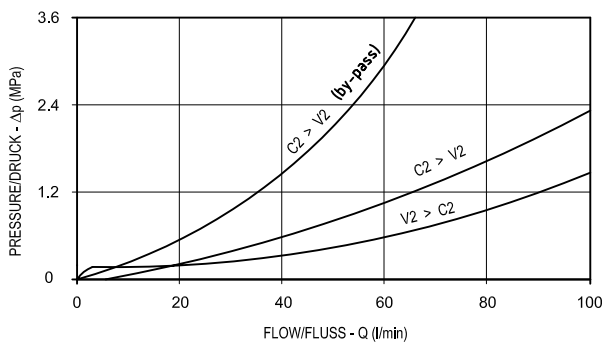

ORDERING INSTRUCTIONS - BESTELLANLEITUNG

14415610 0

Valve Ventil	Spring pressure range Feder-Einstellbereich	Pressure increase MPa/turn Drucksteigerung MPa je Schraubendrehung	Standard setting MPa Standardeinstellung MPa	Port size - Gewinde V2, C2 E, Pil
2	1	10-35 MPa	10	23 (3 l/min)
02	G 3/8"			G 1/4"
03	G 1/2"			

VBG-SE-100-BP

TECHNICAL DATA TECHNISCHE ANGABEN

Max operating pressure Maximaler Betriebsdruck	35 MPa 5076 psi
Max flow Volumenstrom	100 l/min 26.4 gpm
Weight Gewicht	3 kg
Material Material	Zinc coated steel Verzinkter Stahl
Pilot ratio Steuerverhältnis	4.2:1

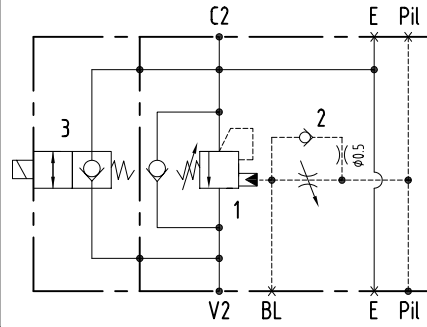

Diagram/Diagramm

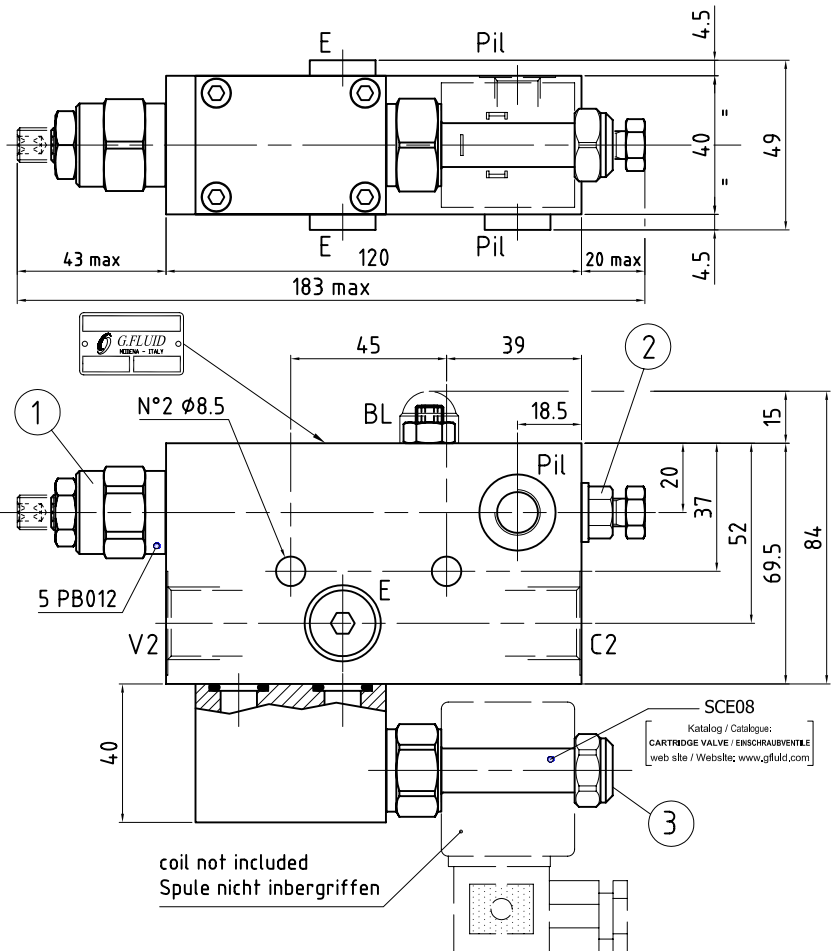
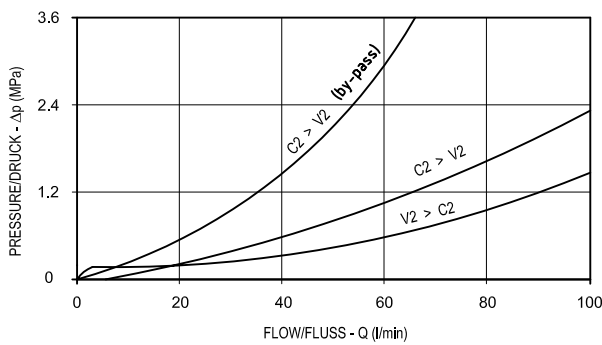

ORDERING INSTRUCTIONS - BESTELLANLEITUNG

14415510 0

Valve Ventil	Spring pressure range Feder-Einstellbereich	Pressure increase MPa/turn Drucksteigerung MPa je Schraubendrehung	Standard setting MPa Standardeinstellung MPa	Port size - Gewinde V2, C2 E, Pil
2	1	10-35 MPa	10	23 (3 l/min)
02				G 3/8"
03				G 1/2" G 1/4"

GVS-VMG31I-PB010-38-020-THM

TECHNICAL DATA
TECHNISCHE ANGABEN

Max operating pressure Maximaler Betriebsdruck	20 MPa 2844 psi
Max flow Volumenstrom	40 l/min 10.6 gpm
Temperature range Betriebstemperatur	-20°/80°C
Filtration Filtergrad	40µ
Weight Gewicht	1.0 kg
Material	Alloy Aluminium
Pilot ratio Steuerverhältnis	4:1

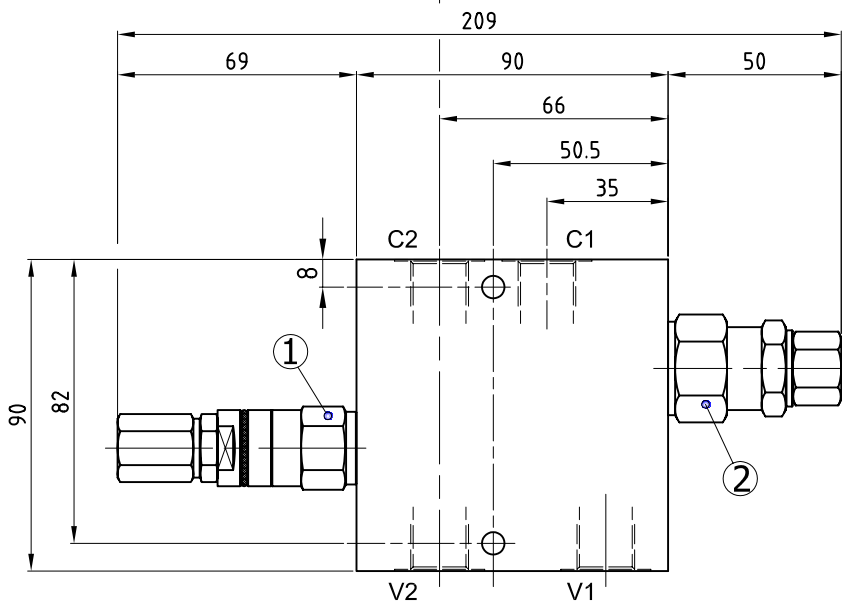
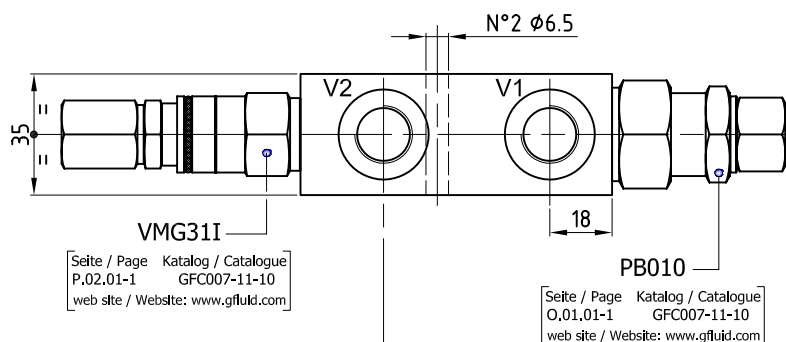
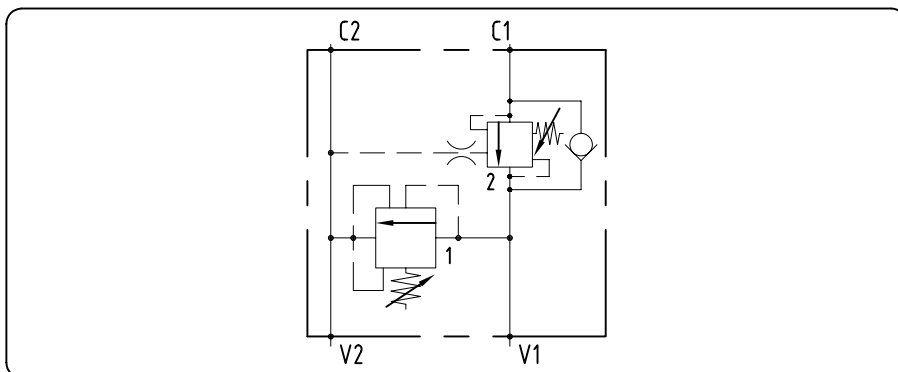

PORT SIZE
GEWINDE

V1, V2, C1, C2	G 3/8"

ORDERING INSTRUCTIONS - BESTELLANLEITUNG
020.03.09.00

An overcenter valve with compact dimensions and good tolerance to oil contamination. It uses same components as PB010 valve, with excellent control in a wide flow and pressure range. The steel body is designed for heavy duty applications. Pressure setting at least 1.3 times the load induced pressure.

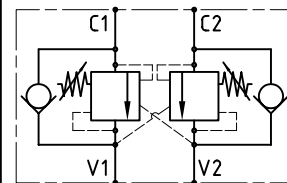
Dieses Ventil ist durch seine kompakten Maße und seine gute Toleranz bezüglich einer eventuellen Ölverschmutzung gekennzeichnet. Es besteht aus den gleichen Komponenten wie das Ventil PB010. Dank seines Stahlgehäuses ist dieses Ventil auch für schwere Anwendungen geeignet. Sehr gute Kontrolle innerhalb eines weiten Volumenstrom- und Druckbereiches. Druckeinstellung 1.3x Ladedruck.

TECHNICAL DATA
TECHNISCHE ANGABEN

Max operating pressure Maximaler Betriebsdruck	21 MPa-2987 psi (Alloy/Aluminium) 35 MPa-5076 psi (Zincoated Steel/Verzink. Stahl)
Max flow Volumenstrom	40 l/min 10.6 gpm
Temperature range Betriebstemperatur	-20°/80°C
Filtration Filtergrad	40µ
Pilot ratio Versteuerverhältnis	4.1:1

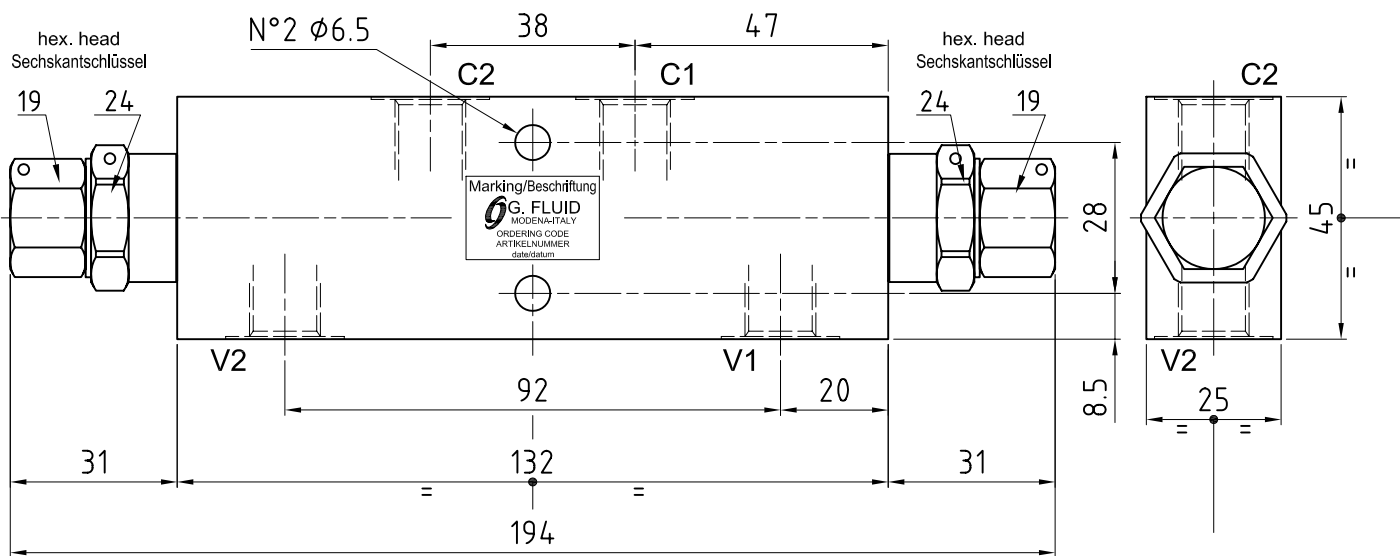
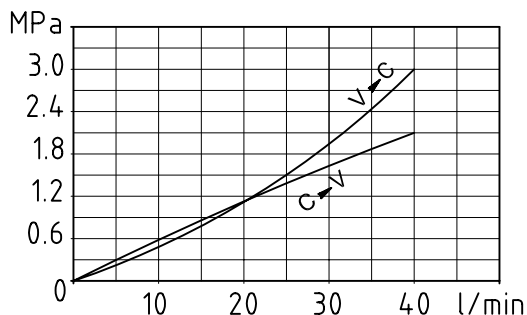
ORDERING CODE - ARTIKELNUMMER
14411906

	Adj. range Regelbereich	std setting Standardeinst.	Pressure increase MPa/turn Drucksteigerung MPa je Schraubendrehung	Port size/Gewinde V1, V2, C1, C2	Material Material	Weigth Gewicht	Description Bezeichnung
2	10-35 MPa	30 MPa	11.6	01 G 1/4"	0 AlloyAluminium	0.6 kg	VBG-DE-78-A
					1 Zincoated Steel/ Verzinkter Stahl	1.2 kg	VBG-DE-78-S

An overcenter valve with compact dimensions and good tolerance to oil contamination. It uses same components as PB012 valve, with excellent control in a wide flow and pressure range.

The steel body is designed for heavy duty applications.

Pressure setting at least 1.3 times the load induced pressure.

Dieses Ventil ist durch seine kompakten Maße und seine gute Toleranz bezüglich einer eventuellen Ölverschmutzung gekennzeichnet. Es besteht aus den gleichen Komponenten wie das Ventil PB012. Dank seines Stahlgehäuses ist dieses Ventil auch für schwere Anwendungen geeignet. Sehr gute Kontrolle innerhalb eines weiten Volumenstrom- und Druckbereiches.

Druckeinstellung 1.3x Ladedruck.

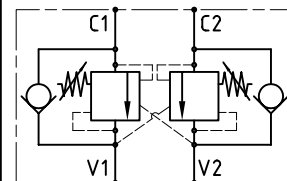
TECHNICAL DATA
TECHNISCHE ANGABEN

Max operating pressure Maximaler Betriebsdruck	21 MPa-2987 psi (Alloy/Aluminium) 35 MPa-5076 psi (Zincoated Steel/Verzinkt Stahl)
Max flow Volumenstrom	60 l/min 15.9 gpm
Temperature range Betriebstemperatur	-20°/80°C
Filtration Filtergrad	40µ
Pilot ratio Versteuerverhältnis	4.25:1

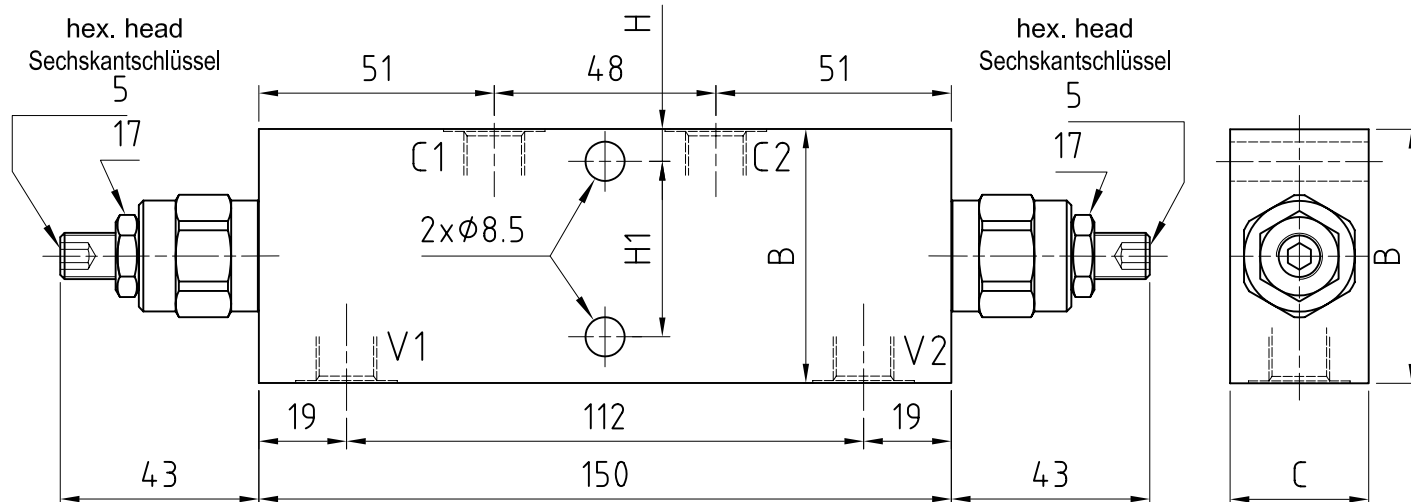
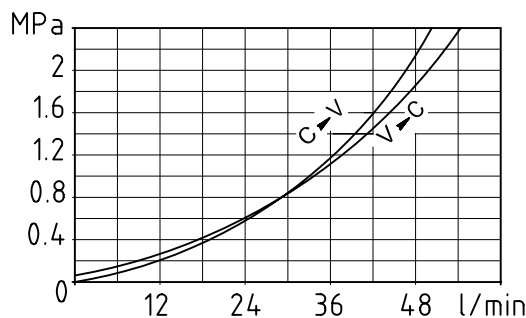

V,C	B	C	H	H1
3/8" BSPP	55	30	8.5	38
1/2" BSPP	65	35	11	43

ORDERING INSTRUCTIONS - BESTELLANLEITUNGEN
14 41 20 10 X Y W

Spring pressure range Feder-Einstellbereich	Pressure increase MPa/turn Drucksteigerung MPa je Schraubendrehung	Standard setting MPa Standard Einstellung MPa	X
6-21 MPa	5.6	20	1
10-35 MPa	10	35	2

W	Material Material
0	Steel / Stahl
1	Alloy / Aluminium
Z	Thread - Gewinde
02	3/8" BSPP
03	1/2" BSPP

An overcenter valve with compact dimensions and good tolerance to oil contamination. It uses same components as PB012 valve, with excellent control in a wide flow and pressure range. The steel body is designed for heavy duty applications. Pressure setting at least 1.3 times the load induced pressure.

Dieses Ventil ist durch seine kompakten Maße und seine gute Toleranz bezüglich einer eventuellen Ölverschmutzung gekennzeichnet. Es besteht aus den gleichen Komponenten wie das Ventil PB012. Dank seines Stahlgehäuses ist dieses Ventil auch für schwere Anwendungen geeignet. Sehr gute Kontrolle innerhalb eines weiten Volumenstrom- und Druckbereiches. Druckeinstellung 1.3x Ladedruck.

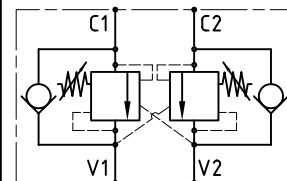
TECHNICAL DATA
TECHNISCHE ANGABEN

Max operating pressure Maximaler Betriebsdruck	21 MPa-2987 psi (Alloy/Aluminium) 35 MPa-5076 psi (Zincoated Steel/Verzink. Stahl)
Max flow Volumenstrom	60 l/min 15.9 gpm
Temperature range Betriebstemperatur	-20°/80°C
Filtration Filtergrad	40µ
Pilot ratio Versteuerverhältnis	4.25:1

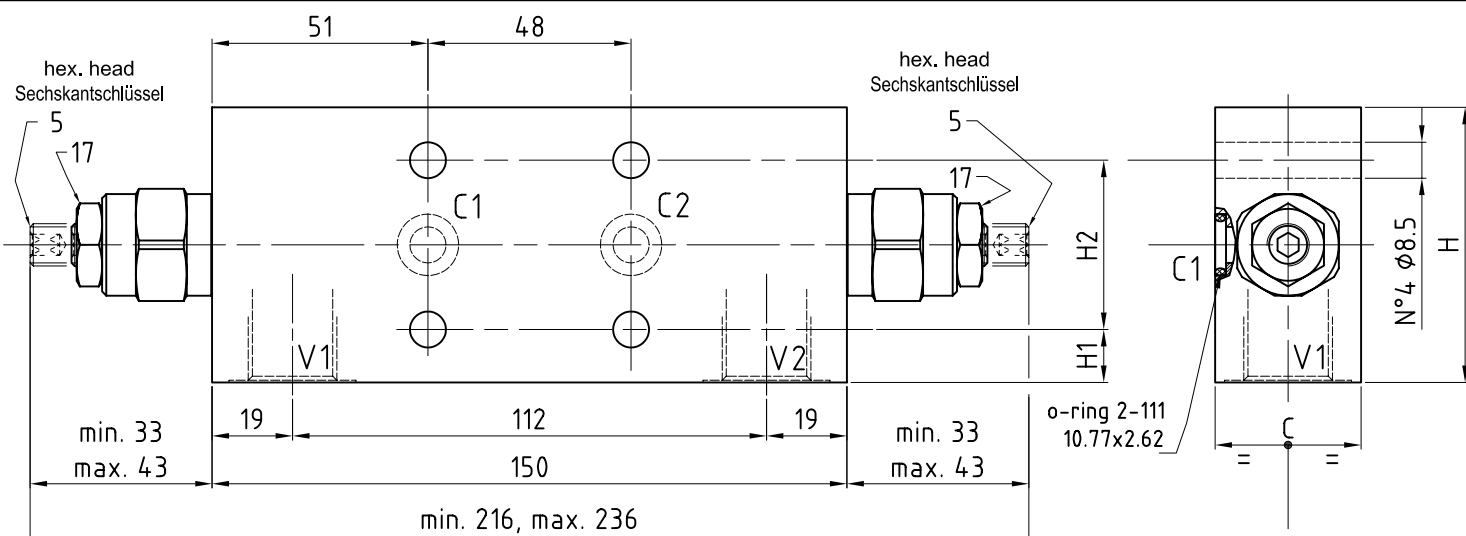
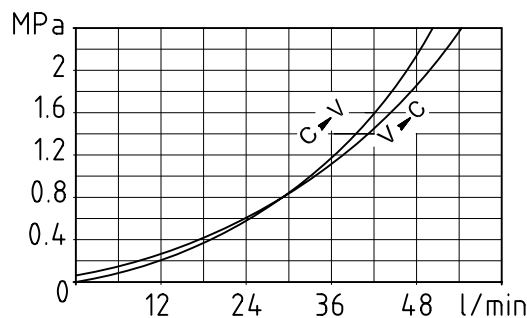

V,C	H1	H2	H	C
3/8" BSPP	7.5	40	55	29.5
1/2" BSPP	12.5	40	65	34.5

ORDERING INSTRUCTIONS - BESTELLEANLEITUNGEN
14 51 20 10 X Y W

Spring pressure range Feder-Einstellbereich	Pressure increase MPa/turn Drucksteigerung MPa je Schraubendrehung	Standard setting MPa Standard Einstellung MPa	X
6-21 MPa	5.6	20	1
10-35 MPa	10	35	2

W	Material Material
0	Steel / Stahl
1	Alloy / Aluminium
Z	Thread - Gewinde V1, V2 C1, C2
02	3/8" BSPP
03	1/2" BSPP

An overcenter valve with compact dimensions and good tolerance to oil contamination. It uses same components as PB012 valve, with excellent control in a wide flow and pressure range. The steel body is designed for heavy duty applications. Pressure setting at least 1.3 times the load induced pressure.

Dieses Ventil ist durch seine kompakten Maße und seine gute Toleranz bezüglich einer eventuellen Ölverschmutzung gekennzeichnet. Es besteht aus den gleichen Komponenten wie das Ventil PB012. Dank seines Stahlgehäuses ist dieses Ventil auch für schwere Anwendungen geeignet. Sehr gute Kontrolle innerhalb eines weiten Volumenstrom- und Druckbereiches. Druckeinstellung 1.3x Ladedruck.

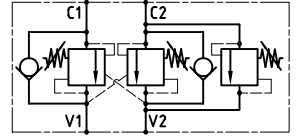
**TECHNICAL DATA
 TECHNISCHE ANGABEN**

Max operating pressure Maximaler Betriebsdruck	21 MPa-2987 psi (Alloy/Aluminium) 35 MPa-5076 psi (Zincoated Steel/Verzinkt Stahl)
Max flow Volumenstrom	60 l/min 15.9 gpm
Temperature range Betriebstemperatur	-20°/80°C
Filtration Filtergrad	40µ
Pilot ratio Versteuerverhältnis	4.25:1

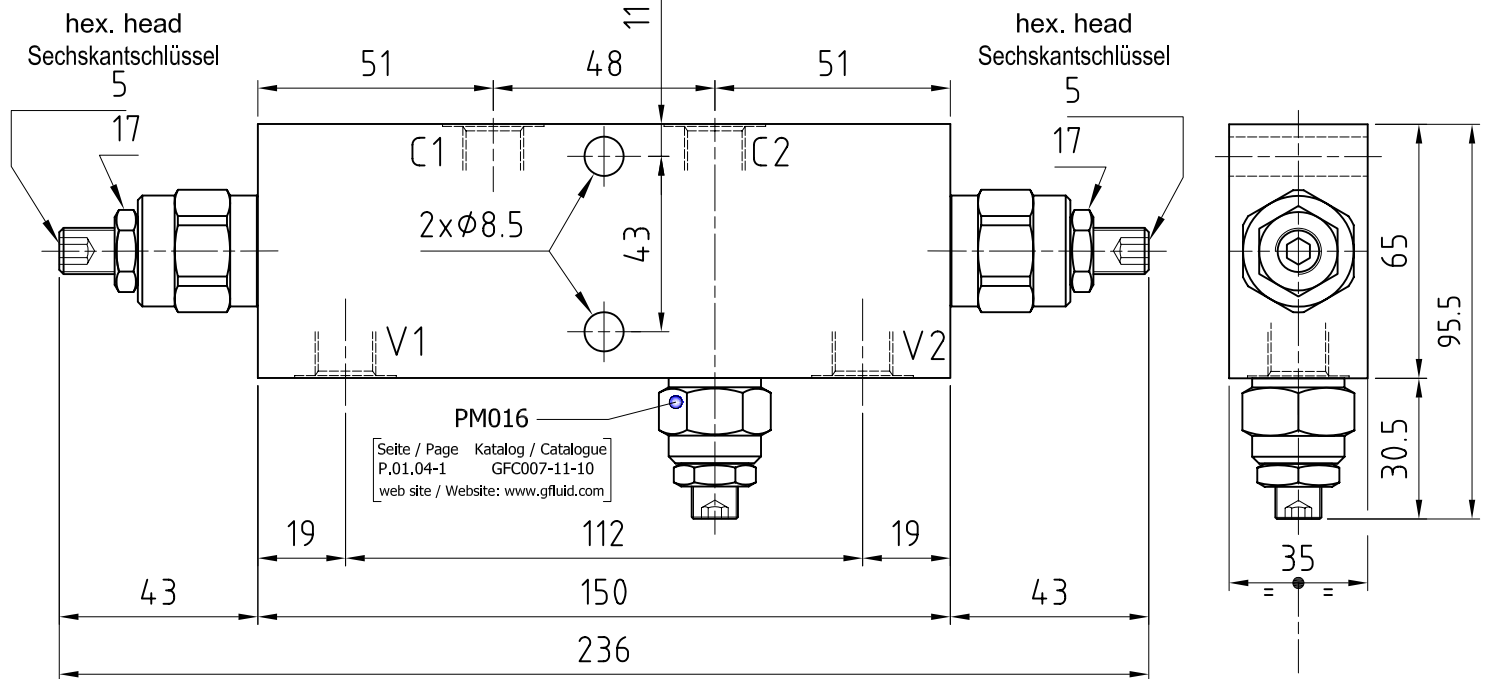
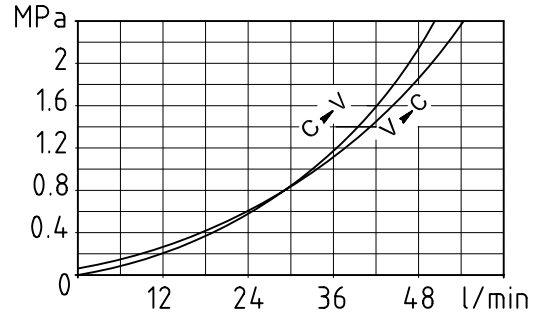

ORDERING INSTRUCTIONS - BESTELLANLEITUNGEN
14 41 23 10 X Y W

Spring pressure range Feder-Einstellbereich	Pressure increase MPa/turn Drucksteigerung MPa je Schraubendrehung	Standard setting MPa Standard Einstellung MPa	X
6-21 MPa	5.6	20	1
10-35 MPa	10	35	2

W	Material Material
0	Steel / Stahl
1	Alloy / Aluminium
Z	Thread - Gewinde
03	1/2" BSPP

An overcenter valve with compact dimensions and good tolerance to oil contamination. It uses same components as PB012 valve, with excellent control in a wide flow and pressure range. The steel body is designed for heavy duty applications. Pressure setting at least 1.3 times the load induced pressure.

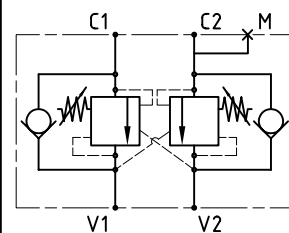
Dieses Ventil ist durch seine kompakten Maße und seine gute Toleranz bezüglich einer eventuellen Ölverschmutzung gekennzeichnet. Es besteht aus den gleichen Komponenten wie das Ventil PB012. Dank seines Stahlgehäuses ist dieses Ventil auch für schwere Anwendungen geeignet. Sehr gute Kontrolle innerhalb eines weiten Volumenstrom- und Druckbereiches. Druckeinstellung 1.3x Ladedruck.

**TECHNICAL DATA
TECHNISCHE ANGABEN**

Max operating pressure Maximaler Betriebsdruck	21 MPa-2987 psi (Alloy/Aluminium) 35 MPa-5076 psi (Zincoated Steel/Verzinkt Stahl)
Max flow Volumenstrom	60 l/min 15.9 gpm
Temperature range Betriebstemperatur	-20°/80°C
Filtration Filtergrad	40µ
Pilot ratio Verstellverhältnis	4.25:1

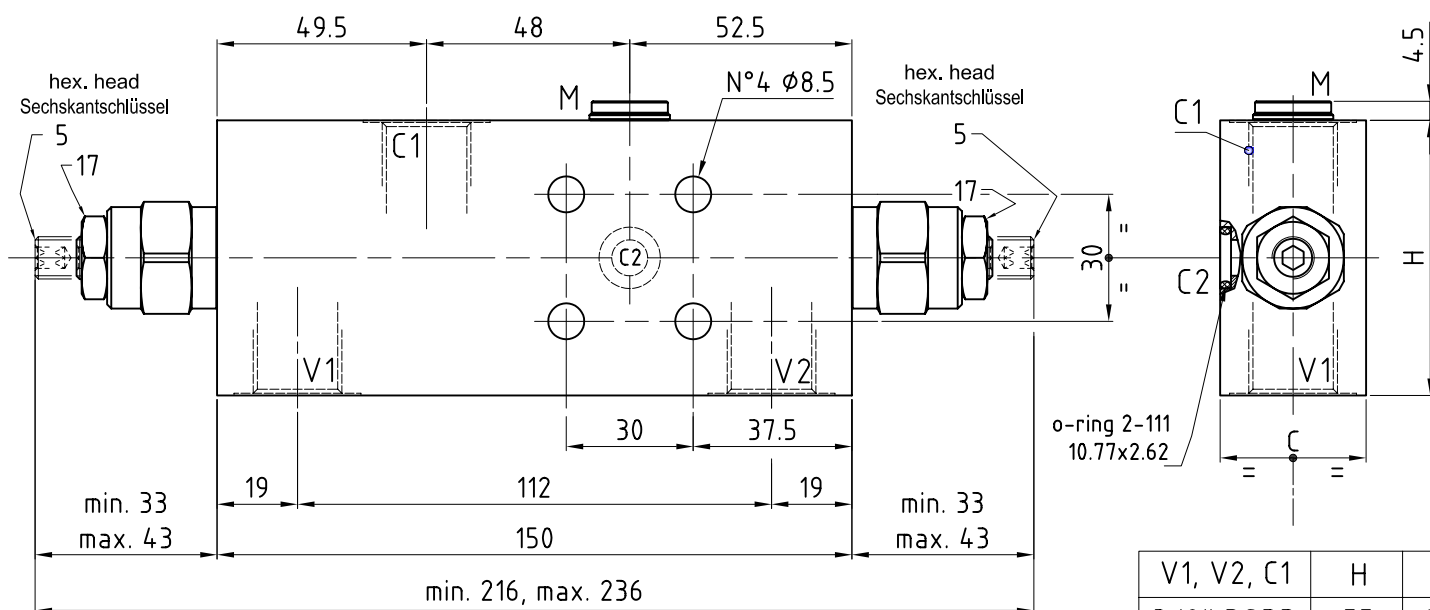
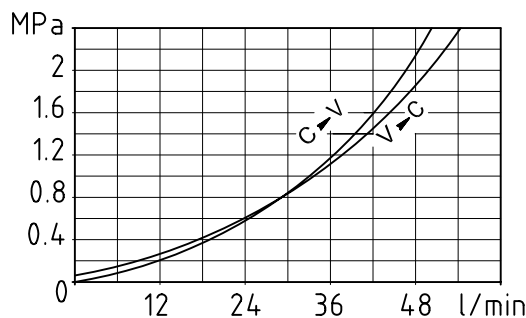
ORDERING INSTRUCTIONS - BESTELLANLEITUNGEN
14 51 21 10 X Y W

Spring pressure range Feder-Einstellbereich	Pressure increase MPa/turn Drucksteigerung MPa je Schraubendrehung	Standard setting MPa Standard Einstellung MPa	X
6-21 MPa	5.6	20	1
10-35 MPa	10	35	2

W	Material Material
0	Steel / Stahl
1	Alloy / Aluminium

Z	Thread - Gewinde		
	V1, V2, C1	M	C1, C2
02	3/8" BSPP	1/4" BSPP	Ø8.5
03	1/2" BSPP		

An overcenter valve with compact dimensions and good tolerance to oil contamination. The steel body is designed for heavy duty applications. Pressure setting at least 1.3 times the load induced pressure.

Dieses Ventil ist durch seine kompakten Maße und seine gute Toleranz bezüglich einer eventuellen Ölverschmutzung gekennzeichnet. Dank seines Stahlgehäuses ist dieses Ventil auch für schwere Anwendungen geeignet. Sehr gute Kontrolle innerhalb eines weiten Volumenstrom- und Druckbereiches. Druckeinstellung 1.3x Ladedruck.

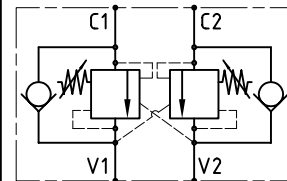
TECHNICAL DATA
TECHNISCHE ANGABEN

Max operating pressure Maximaler Betriebsdruck	21 MPa-2987 psi (Alloy/Aluminium) 35 MPa-5076 psi (Zincoated Steel/Verzinkt. Stahl)
Max flow Volumenstrom	70 l/min 18.5 gpm
Temperature range Betriebstemperatur	-20°/80°C
Filtration Filtergrad	40µ

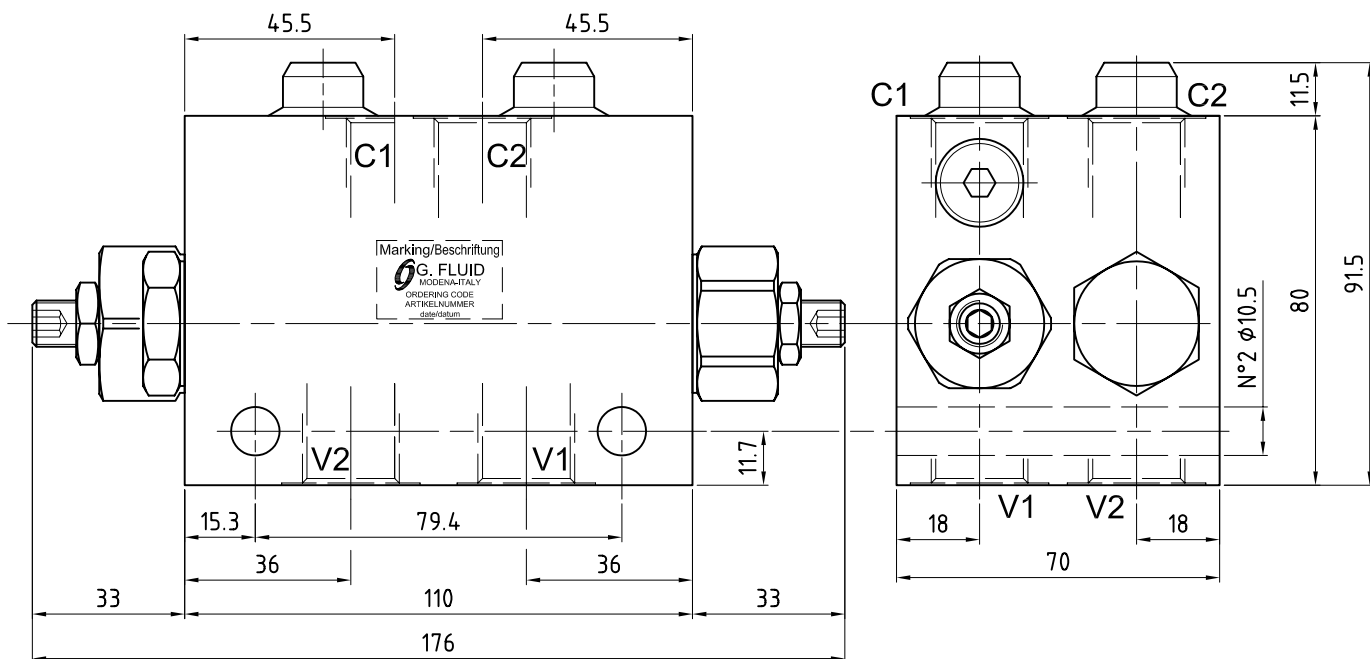
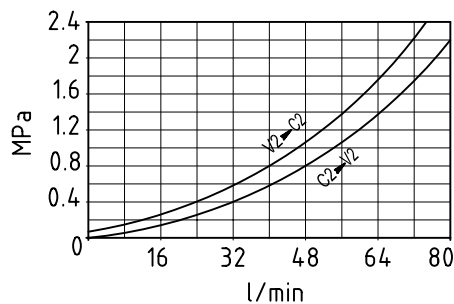
ORDERING CODE - ARTIKELNUMMER
144181 00

Pilot ratio Steuerverhältnis	Adj. range Regelbereich	std setting Standardeinst.	Pressure increase MPa/turn Drucksteigerung MPa/je Schraubendrehung	Port size/Gewinde V1, V2, C1, C2	Material Material	Weigth Gewicht	Description Bezeichnung
03 3:1	1 6-21 MPa	20 MPa	4.4	03 G 1/2"	0 Alloy/Aluminium	1.7 kg	VBG-SE-81-A
15 10.5:1	2 10-35 MPa	35 MPa	8.0		1 Zincoated Steel/ Verzinkter Stahl	4.8 kg	VBG-SE-81-S

An overcenter valve with compact dimensions and good tolerance to oil contamination. It uses same components as PB112 valve, with excellent control in a wide flow and pressure range. The steel body is designed for heavy duty applications. The poppet is pressure balanced, preventing relief setting increase due to back pressure. Pressure setting at least 1.3 times the load induced pressure.

Dieses Ventil ist durch seine kompakten Maße und seine gute Toleranz bezüglich einer eventuellen Ölverschmutzung gekennzeichnet. Es besteht aus den gleichen Komponenten wie das Ventil PB112. Dank seines Stahlgehäuses ist dieses Ventil auch für schwere Anwendungen geeignet. Sehr gute Kontrolle innerhalb eines weiten Volumenstrom- und Druckbereiches. Der Kegel ist druckkompensiert und verhindert dank des Rückdrucks den Anstieg der Druckeinstellung. Druckeinstellung 1.3x Ladedruck.

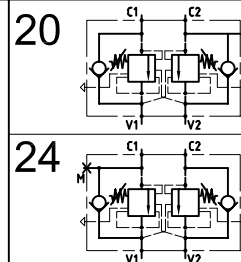
TECHNICAL DATA
TECHNISCHE ANGABEN

Max operating pressure Maximaler Betriebsdruck	21 MPa-2987 psi (Alloy/Aluminium) 35 MPa-5076 psi (Zincoated Steel/Verzinkt. Stahl)
Max flow Volumenstrom	60 l/min 15.9 gpm
Temperature range Betriebstemperatur	-20°/80°C
Filtration Filtergrad	40µ
Pilot ratio Versteuerverhältnis	4.25:1

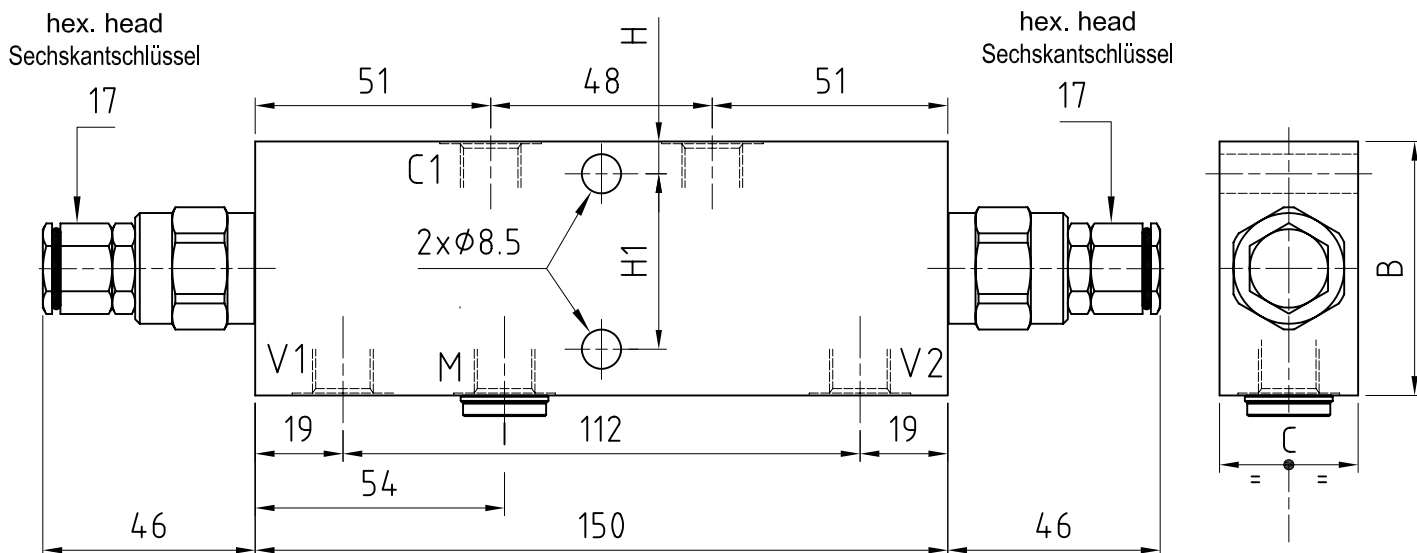
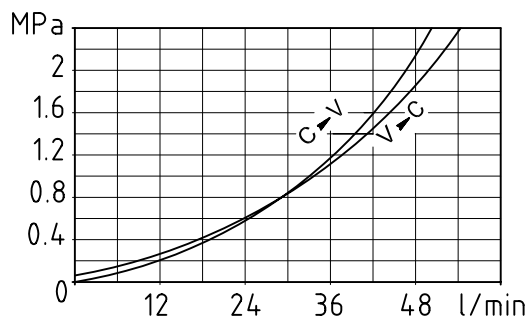

V,C	B	C	H	H1
3/8" BSPP	55	30	8.5	38
1/2" BSPP	65	35	11	43

ORDERING CODE - ARTIKELNUMMER
1441 20

Scheme Schema	Adj. range Regelbereich	std setting Standardeinst.	Pressure increase MPa/turn Drucksteigerung MPa je Schraubendrehung	Port size/Gewinde C1, C2, V1, V2 M	Material Material	Weight/Gewicht G 3/8" G 1/2"
20 without/ohne: M	1 6-21 MPa	20 MPa	5.6	02 G 3/8"	Zincoated Steel/ Verzinkter Stahl	2.0 kg 2.8 kg
24 with/mit: M	2 10-35 MPa	35 MPa	10.0	03 G 1/2" G 1/4"	1 Alloy/Aluminium	0.8 kg 1.0 kg

An overcenter valve with compact dimensions and good tolerance to oil contamination. It uses same components as PB112 valve, with excellent control in a wide flow and pressure range. The steel body is designed for heavy duty applications. The poppet is pressure balanced, preventing relief setting increase due to back pressure. Pressure setting at least 1.3 times the load induced pressure.

Dieses Ventil ist durch seine kompakten Maße und seine gute Toleranz bezüglich einer eventuellen Ölverschmutzung gekennzeichnet. Es besteht aus den gleichen Komponenten wie das Ventil PB112. Dank seines Stahlgehäuses ist dieses Ventil auch für schwere Anwendungen geeignet. Sehr gute Kontrolle innerhalb eines weiten Volumenstrom- und Druckbereiches. Der Kegel ist druckkompensiert und verhindert dank des Rückdrucks den Anstieg der Druckeinstellung. Druckeinstellung 1.3x Ladedruck.

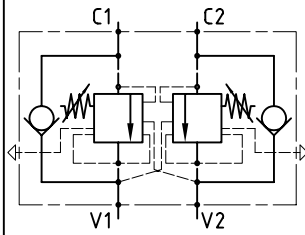
**TECHNICAL DATA
TECHNISCHE ANGABEN**

Max operating pressure Maximaler Betriebsdruck	21 MPa-2987 psi (Alloy/Aluminium) 35 MPa-5076 psi (Zincoated Steel/Verzink. Stahl)
Max flow Volumenstrom	60 l/min 15.9 gpm
Temperature range Betriebstemperatur	-20°/80°C
Filtration Filtergrad	40µ
Pilot ratio Verstellungsverhältnis	4.25:1

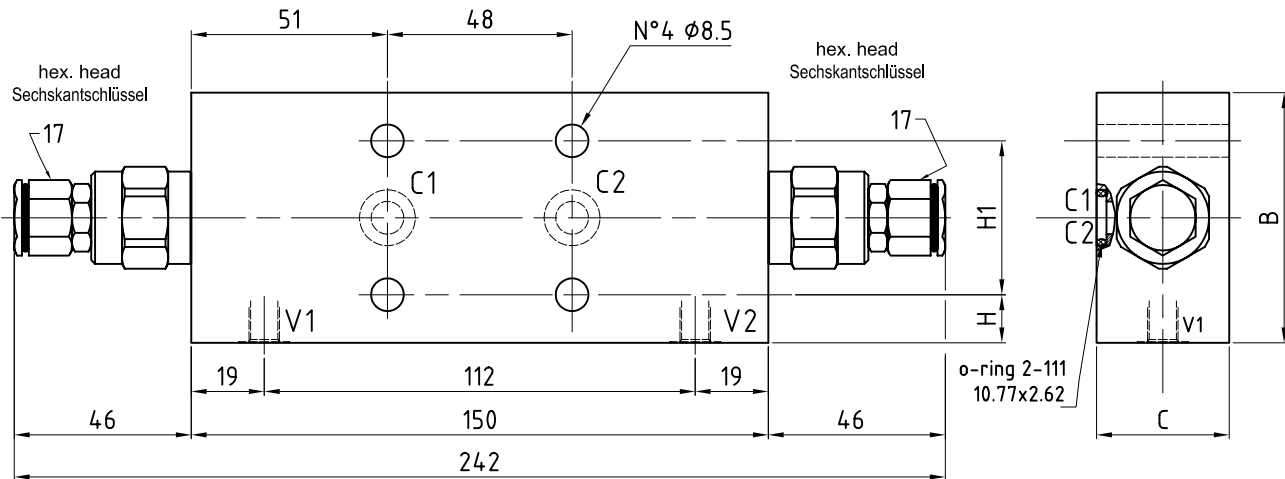
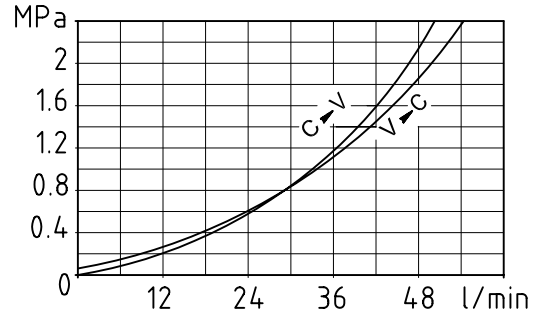

V,C	B	C	H	H1
3/8" BSPP	55	29.5	7.5	40
1/2" BSPP	65	34.5	12.5	40

ORDERING INSTRUCTIONS - BESTELLANLEITUNG
14 51 20 20 - - -

	Spring pressure range Feder-Einstellbereich	Pressure increase MPa/turn Drucksteigerung MPa je Schraubendrehung	Standard setting MPa Standard Einstellung Pa	Port size/Gewinde V1, V2 C1, C2	Material Material
1	6-21 MPa	0.9	20	02 G 3/8" Ø8.5	0 Steel/Stahl
2	10-35 MPa	1.9	35	03 G 1/2" Ø8.5	1 Alloy/Aluminium

An overcenter valve with compact dimensions and good tolerance to oil contamination. It uses same components as PB033 valve, with excellent control in a wide flow and pressure range. The steel body is designed for heavy duty applications. Pressure setting at least 1.3 times the load induced pressure.

Dieses Ventil ist durch seine kompakten Maße und seine gute Toleranz bezüglich einer eventuellen Ölverschmutzung gekennzeichnet. Es besteht aus den gleichen Komponenten wie das Ventil PB033. Dank seines Stahlgehäuses ist dieses Ventil auch für schwere Anwendungen geeignet. Sehr gute Kontrolle innerhalb eines weiten Volumenstrom- und Druckbereiches. Druckeinstellung 1.3x Ladedruck.

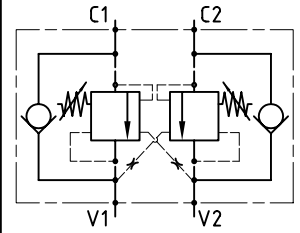
TECHNICAL DATA
TECHNISCHE ANGABEN

Max operating pressure Maximaler Betriebsdruck	21 MPa-2987 psi (Alloy/Aluminium) 35 MPa-5076 psi (Zincoated Steel/Verzink. Stahl)
Max flow Volumenstrom	150 l/min 39.6 gpm
Temperature range Betriebstemperatur	-40°/80°C
Filtration Filtergrad	40µ
Pilot ratio Versterverhältnis	4:1

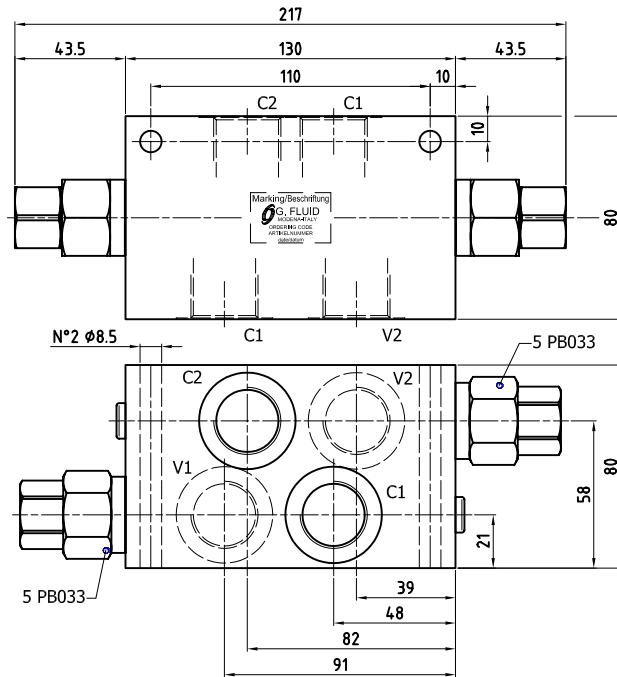
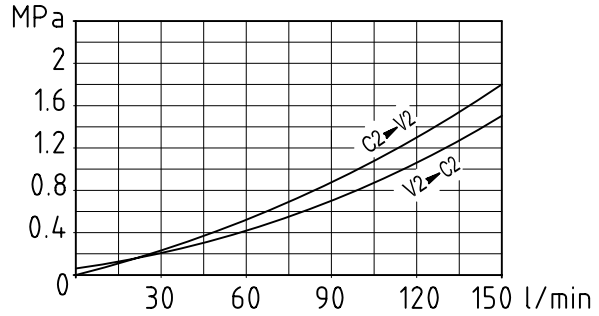
ORDERING CODE - ARTIKELNUMMER
14414434

	Adj. range Regelbereich	std setting Standardeinst.	Pressure increase MPa/turn Drucksteigerung MPa je Schraubendrehung	Port size/Gewinde V1, V2, C1, C2	Material Material	Weight Gewicht
2	10-35 MPa	30 MPa	10.0	03 04 G 1/2" G 3/4"	0 Alloy/Aluminium 1 Zincoated Steel/ Verzinkter Stahl	2.4 kg 6.7 kg

An overcenter valve with compact dimensions and good tolerance to oil contamination. It uses same components as PB033 valve, with excellent control in a wide flow and pressure range. The steel body is designed for heavy duty applications. Pressure setting at least 1.3 times the load induced pressure.

Dieses Ventil ist durch seine kompakten Maße und seine gute Toleranz bezüglich einer eventuellen Ölverschmutzung gekennzeichnet. Es besteht aus den gleichen Komponenten wie das Ventil PB033. Dank seines Stahlgehäuses ist dieses Ventil auch für schwere Anwendungen geeignet. Sehr gute Kontrolle innerhalb eines weiten Volumenstrom- und Druckbereiches. Druckeinstellung 1.3x Ladedruck.

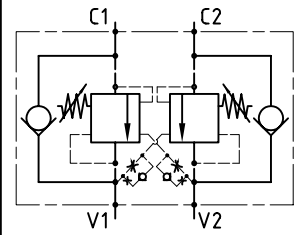
TECHNICAL DATA
TECHNISCHE ANGABEN

Max operating pressure Maximaler Betriebsdruck	21 MPa-2987 psi (Alloy/Aluminium) 35 MPa-5076 psi (Zincoated Steel/Verzink. Stahl)
Max flow Volumenstrom	150 l/min 39.6 gpm
Temperature range Betriebstemperatur	-40°/80°C
Filtration Filtergrad	40µ
Pilot ratio Versteuerverhältnis	4:1

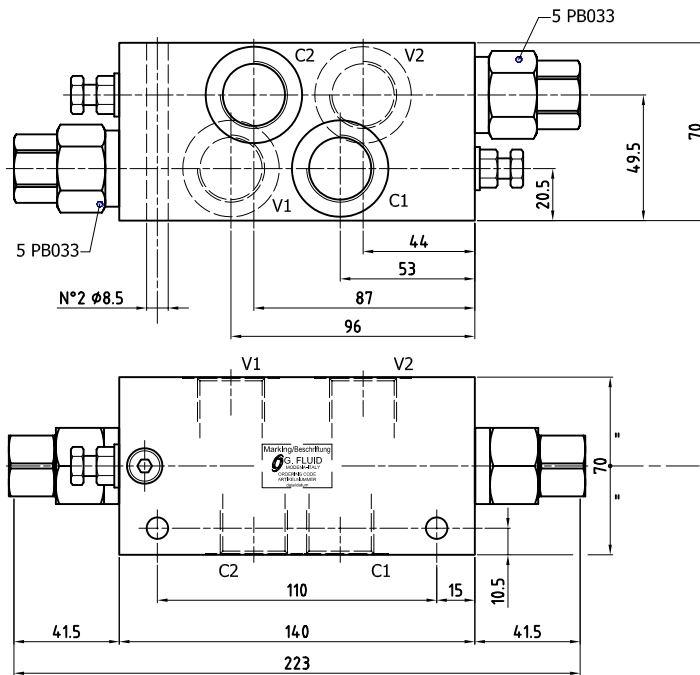
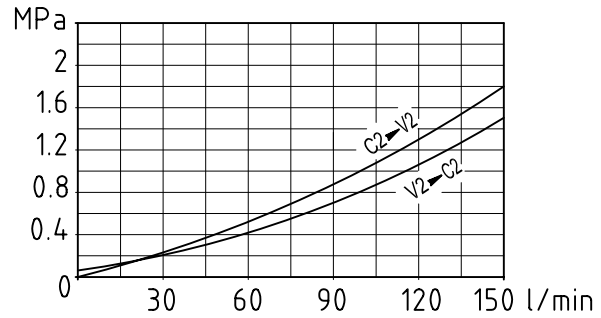
ORDERING CODE - ARTIKELNUMMER
14414534

	Adj. range Regelbereich	std setting Standardeinst.	Pressure increase MPa/turn Drucksteigerung MPa je Schraubendrehung	Port size/Gewinde V1, V2, C1, C2	Material Material	Weight Gewicht
2	10-35 MPa	30 MPa	10.0	03 04 G 1/2" G 3/4"	0 Alloy/Aluminium 1 Zincoated Steel/ Verzinkter Stahl	2.0 kg 5.4 kg

An overcenter valve with compact dimensions and good tolerance to oil contamination. It uses same components as PB033 valve, with excellent control in a wide flow and pressure range. The steel body is designed for heavy duty applications. Pressure setting at least 1.3 times the load induced pressure.

Dieses Ventil ist durch seine kompakten Maße und seine gute Toleranz bezüglich einer eventuellen Ölverschmutzung gekennzeichnet. Es besteht aus den gleichen Komponenten wie das Ventil PB033. Dank seines Stahlgehäuses ist dieses Ventil auch für schwere Anwendungen geeignet. Sehr gute Kontrolle innerhalb eines weiten Volumenstrom- und Druckbereiches. Druckeinstellung 1.3x Ladedruck.

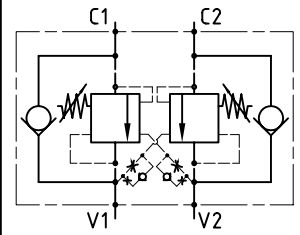
TECHNICAL DATA
TECHNISCHE ANGABEN

Max operating pressure Maximaler Betriebsdruck	21 MPa-2987 psi (Alloy/Aluminium) 35 MPa-5076 psi (Zincoated Steel/Verzink. Stahl)
Max flow Volumenstrom	150 l/min 39.6 gpm
Temperature range Betriebstemperatur	-40°/80°C
Filtration Filtergrad	40µ
Pilot ratio Versteuerverhältnis	4:1

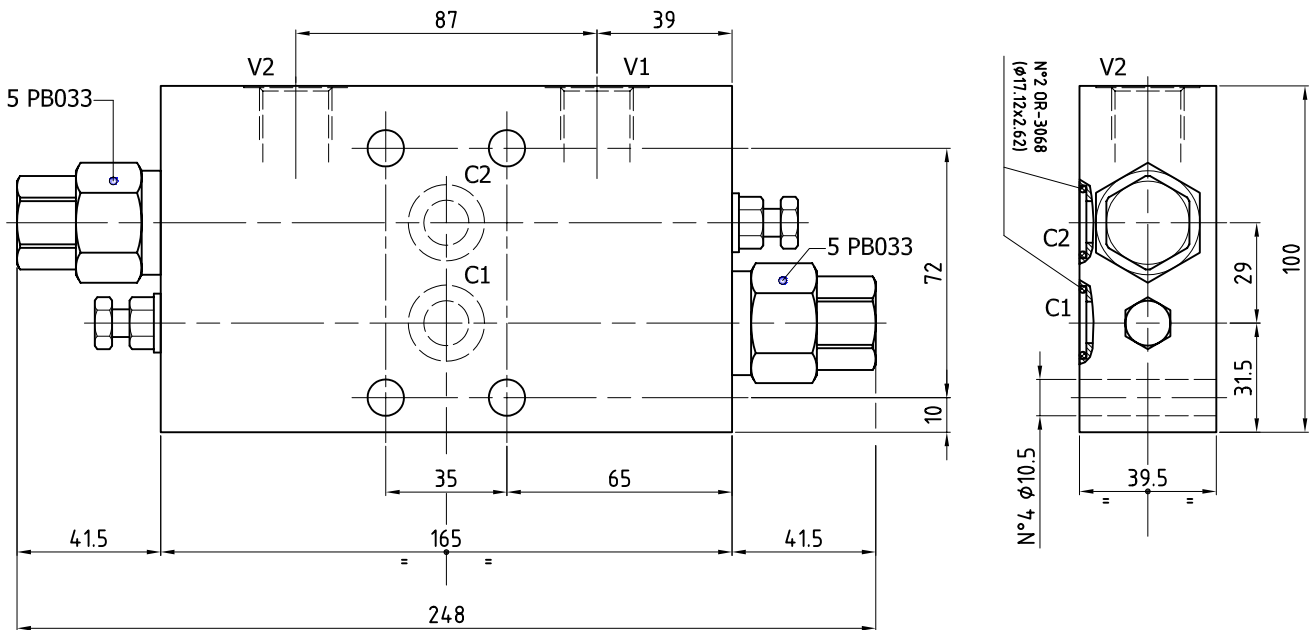
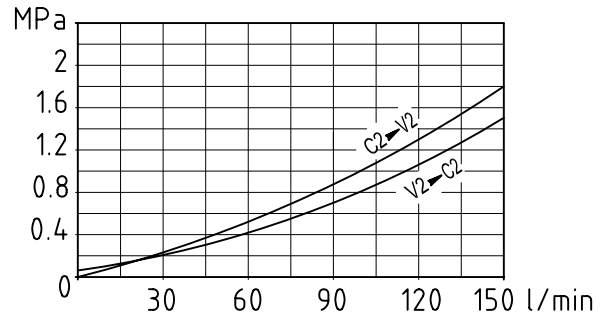
ORDERING INSTRUCTIONS - BESTELLANLEITUNGEN
14 41 46 34 Y W Z

Spring pressure range Feder-Einstellbereich	Pressure increase MPa/turn Drucksteigerung MPa je Schraubendrehung	Standard setting MPa Standard Einstellung MPa	Y
10-35 MPa	10	35	2

Z	Material Material	Weight Gewicht
0	Steel / Stahl	5.1 kg
1	Alloy / Aluminium	1.9 kg

W	Thread - Gewinde V1, V2 C1, C2	
03	1/2" BSPP	Ø12
04	3/4" BSPP	

An overcenter valve with compact dimensions and good tolerance to oil contamination. The body is designed for heavy duty applications. Pressure setting at least 1.3 times the load induced pressure.

Dieses Ventil ist durch seine kompakten Maße und seine gute Toleranz bezüglich einer eventuellen Ölverschmutzung gekennzeichnet. Dank seines Gehäuses ist dieses Ventil auch für schwere Anwendungen geeignet. Sehr gute Kontrolle innerhalb eines weiten Volumenstrom- und Druckbereiches. Druckeinstellung 1.3x Ladedruck.

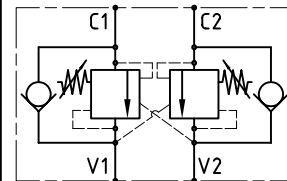
**TECHNICAL DATA
TECHNISCHE ANGABEN**

Max operating pressure Maximaler Betriebsdruck	21 MPa-2987 psi (Alloy/Aluminium) 35 MPa-5076 psi (Zincoated Steel/Verzink. Stahl)
Max flow Volumenstrom	see performance graph siehe Diagramm
Temperature range Betriebstemperatur	-20°/80°C
Filtration Filtergrad	40µ

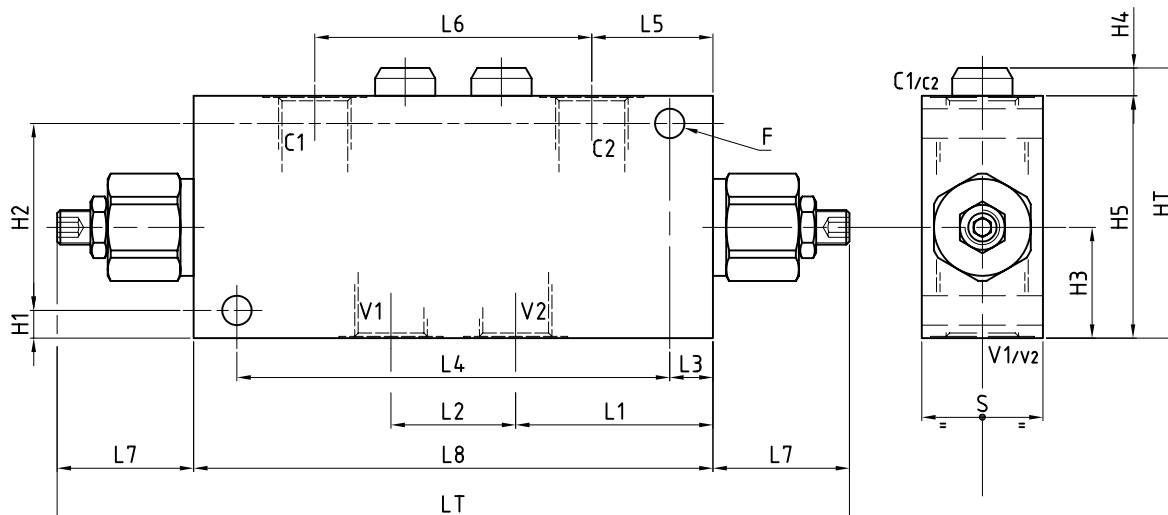
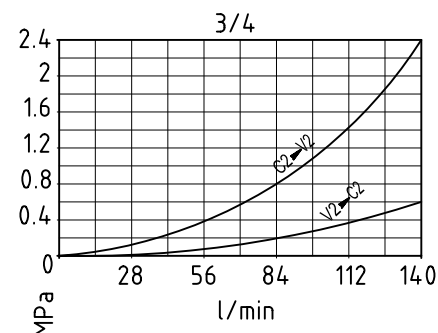
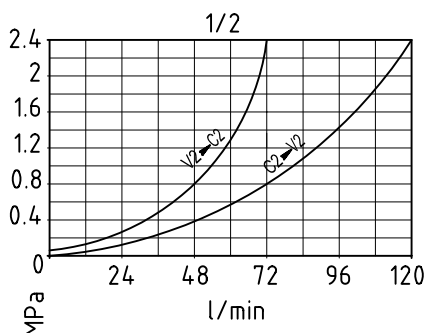

V1,V2,C1, C2	F	L1	L2	L3	L4	L5	L6	L7	L8	LT	H1	H2	H3	H4	H5	HT	S	Weight/Gewicht Alloy/Alumin. - Steel/Stahl	
1/2" BSPP	8.5	57	36	12.5	125	35	80	39.5	150	229	8	54	32	7	70	77	35	1.3	3.0
3/4" BSPP	10.5	62.5	50	10	155	34	107	39.5	175	254	10	70	38	8	90	98	40	2.0	5.3

ORDERING INSTRUCTIONS - BESTELLANLEITUNGEN
14 41 50 X Y W Z

Pilot ratio Steuerverhältnis	X
3.2:1	30
8.2:1	33

Z	Material Material
0	Steel / Stahl
1	Alloy / Aluminium

Spring pressure range Feder-Einstellbereich	Pressure increase MPa/turn Drucksteigerung MPa je Schraubendrehung	Standard setting MPa Standard Einstellung MPa	Y
3-12 MPa	1.6	10	1
8-35 MPa	4.4	35	2

W	Thread - Gewinde V1, V2, C1,C2
03	1/2" BSPP
04	3/4" BSPP

An overcenter valve with compact dimensions and good tolerance to oil contamination. The steel body is designed for heavy duty applications. Pressure setting at least 1.3 times the load induced pressure.

Dieses Ventil ist durch seine kompakten Maße und seine gute Toleranz bezüglich einer eventuellen Ölverschmutzung gekennzeichnet. Dank seines Stahlgehäuses ist dieses Ventil auch für schwere Anwendungen geeignet. Sehr gute Kontrolle innerhalb eines weiten Volumenstrom- und Druckbereiches. Druckeinstellung 1.3x Ladedruck.

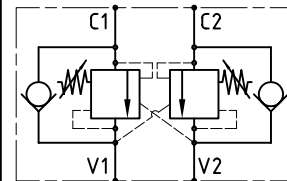

TECHNICAL DATA TECHNISCHE ANGABEN	
Max operating pressure Maximaler Betriebsdruck	21 MPa-2987 psi (Alloy/Aluminium) 35 MPa-5076 psi (Zincoated Steel/Verzink. Stahl)
Max flow Volumenstrom	see performance graph siehe Diagramm
Temperature range Betriebstemperatur	-20°/80°C
Filtration Filtergrad	40µ

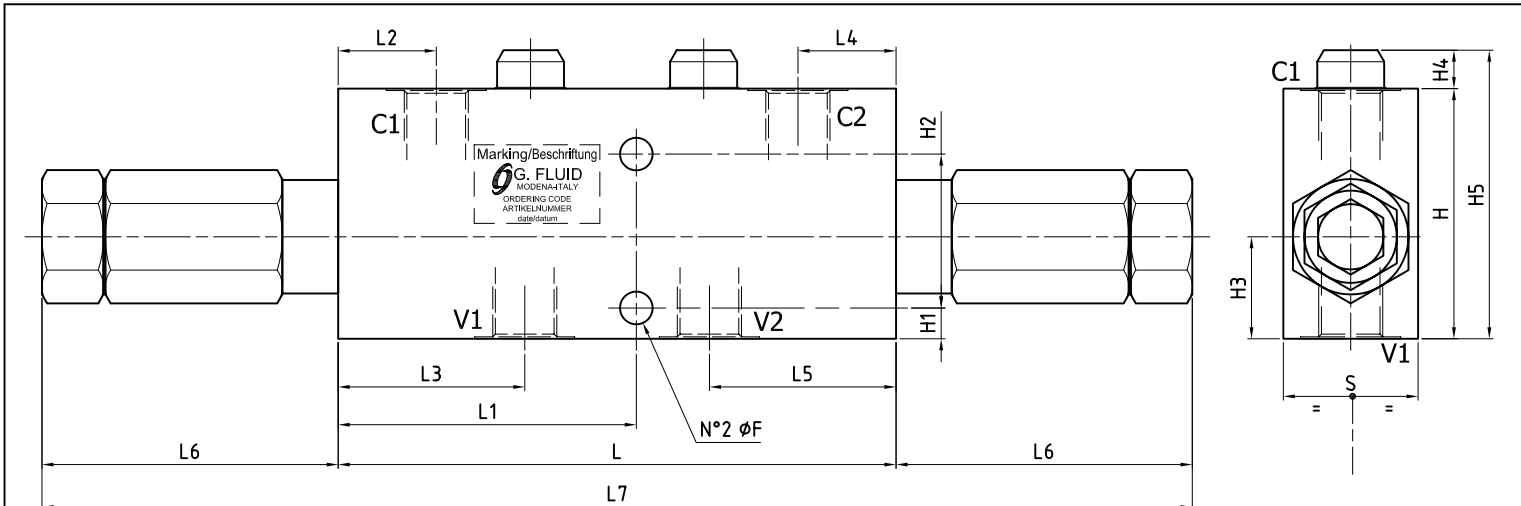
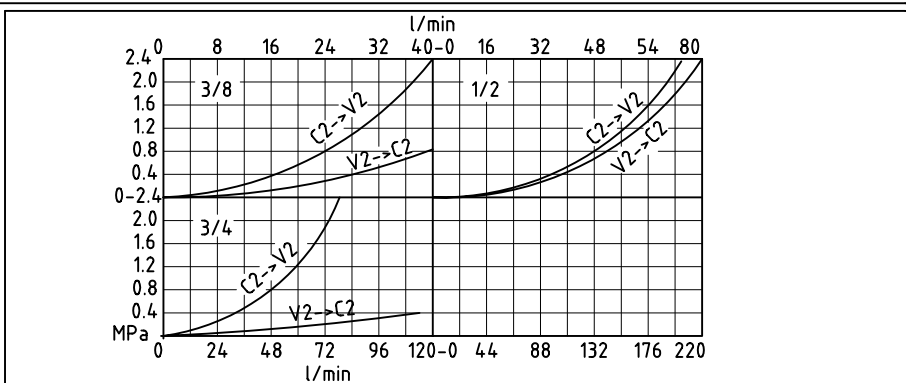

V2, C2	L	L1	L2	L3	L4	L5	L6	L7	H	H1	H2	H3	H4	H5	S	F	Weight/Gewicht (kg)	
																	Alloy/Alumh.	Zinc, Steel/Verzink. Stahl
3/4"G	180	90	29	62	29	62	69	318	90	10	50	35	4.5	94.5	40	10.5	2.6	7.2
1/2"G	155	77.5	27.5	53.5	27.5	53.5	72	299	70	8	48	30	8	78	40	8.5	2.1	5.8
3/8"G	145	72.5	25.5	48.5	25.5	48.5	74	283	65	8	40	26.5	10	75	35	8.5	1.4	3.9

ORDERING CODE - ARTIKELNUMMER
144191 00

17	Pilot ratio Steuerverhältnis	7.6:1	1	Adj. range Regelbereich	6-21 MPa	02	Port size/Gewinde V1, V2, C1, C2	G 3/8"	0	Material	Alloy/Aluminium
	V2/C2 (G)	1/2" - 3/4"		std setting Standardeinst.	20 MPa		Pil	G 1/4"		1	Zincoated Steel/ Verzinkter Stahl
92	Pilot ratio Steuerverhältnis	3.6:1	2	Adj. range Regelbereich	10-35 MPa	03	Port size/Gewinde V1, V2, C1, C2	G 1/2"	1	Material	Zincoated Steel/ Verzinkter Stahl
	V2/C2 (G)	3/8"		std setting Standardeinst.	35 MPa		Pressure increase MPa/turn Drucksteigerung MPa je Schraubendrehung	6.5			
	Pilot ratio Steuerverhältnis	3:1		Adj. range Regelbereich	1/2" - 3/4"	04	Port size/Gewinde V1, V2, C1, C2	G 3/4"			

An overcenter valve with compact dimensions and good tolerance to oil contamination.
 The steel body is designed for heavy duty applications.
 Pressure setting at least 1.3 times the load induced pressure.

Dieses Ventil ist durch seine kompakten Maße und seine gute Toleranz bezüglich einer eventuellen Ölverschmutzung gekennzeichnet.
 Dank seines Stahlgehäuses ist dieses Ventil auch für schwere Anwendungen geeignet. Sehr gute Kontrolle innerhalb eines weiten Volumenstrom- und Druckbereiches.
 Druckeinstellung 1.3x Ladedruck.

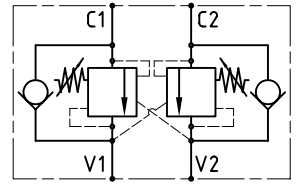
TECHNICAL DATA
TECHNISCHE ANGABEN

Max operating pressure Maximaler Betriebsdruck	21 MPa-2987 psi (Alloy/Aluminium) 35 MPa-5076 psi (Zincoated Steel/Verzink. Stahl)
Max flow Volumenstrom	see performance graph siehe Diagramm
Temperature range Betriebstemperatur	-20°/80°C
Filtration Filtergrad	40µ

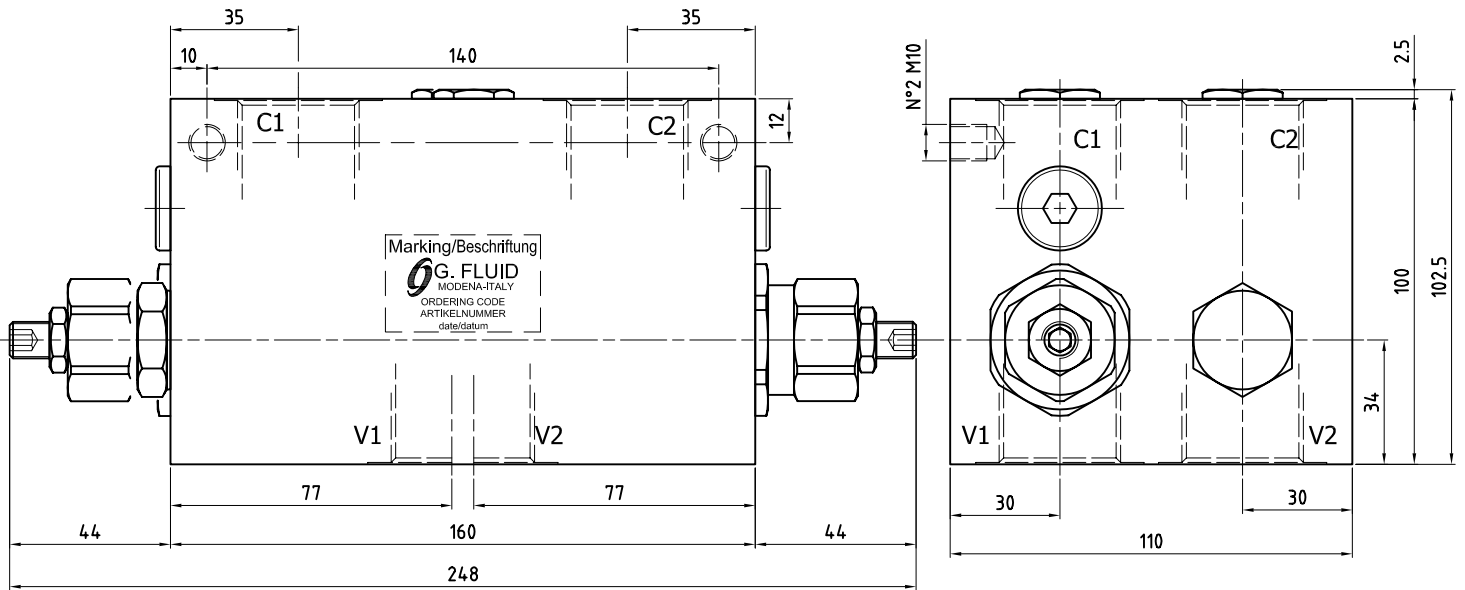
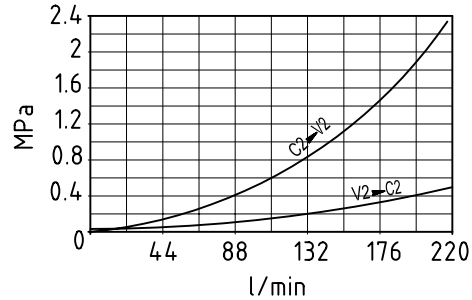
ORDERING CODE - ARTIKELNUMMER
144192 00

Pilot ratio Steuerverhältnis	Adj. range Regelbereich	std setting Standardeinst.	Pressure increase MPa/tum Drucksteigerung MPa je Schraubendrehung	Port size/Gewinde V1, V2, C1, C2	Material Material	Weigth Gewicht	Description Bezeichnung
08 8:1 12 2.8:1	1 6-21 MPa 2 10-35 MPa	20 MPa 35 MPa	2.0 4.4	05 G 1"	0 Alloy/Aluminium 1 Zincoated Steel/ Verzinkter Stahl	7.2 kg 20.0 kg	VBG-DE-92-A VBG-DE-92-S

An overcenter valve with compact dimensions and good tolerance to oil contamination. It uses same components as PB012 valve, with excellent control in a wide flow and pressure range.

The steel body is designed for heavy duty applications.

Pressure setting at least 1.3 times the load induced pressure.

Dieses Ventil ist durch seine kompakten Maße und seine gute Toleranz bezüglich einer eventuellen Ölverschmutzung gekennzeichnet. Es besteht aus den gleichen Komponenten wie das Ventil PB012. Dank seines Stahlgehäuses ist dieses Ventil auch für schwere Anwendungen geeignet. Sehr gute Kontrolle innerhalb eines weiten Volumenstrom- und Druckbereiches.

Druckeinstellung 1.3x Ladedruck.

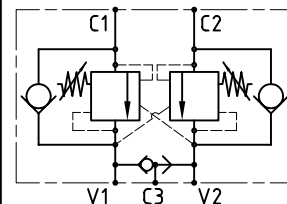
**TECHNICAL DATA
TECHNISCHE ANGABEN**

Max operating pressure Maximaler Betriebsdruck	21 MPa-2987 psi (Alloy/Aluminium) 35 MPa-5076 psi (Zincoated Steel/Verzink. Stahl)
Max flow Volumenstrom	60 l/min 15.9 gpm
Temperature range Betriebstemperatur	-20°/80°C
Filtration Filtergrad	40µ
Pilot ratio Versteuerverhältnis	4.25:1

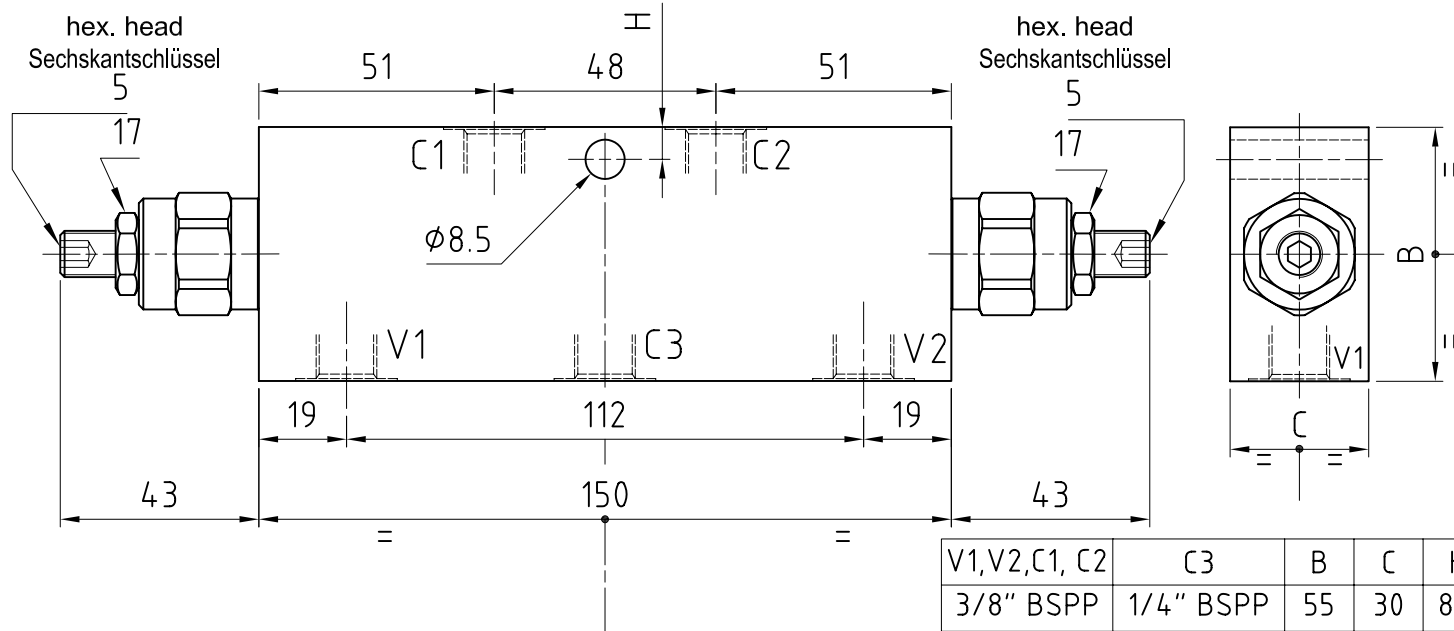
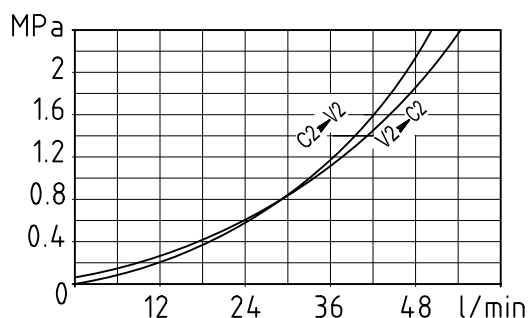

ORDERING INSTRUCTIONS - BESTELLANLEITUNGEN
14 41 22 10 X Y W

Spring pressure range Feder-Einstellbereich	Pressure increase MPa/turn Drucksteigerung MPa je Schraubendrehung	Standard setting MPa Standard Einstellung MPa	X
6-21 MPa	5.6	20	1
10-35 MPa	10	35	2

W	Material Material
0	Steel / Stahl
1	Alloy / Aluminium
Z	Thread - Gewinde
02	3/8" BSPP
03	1/2" BSPP

An overcenter valve with compact dimensions and good tolerance to oil contamination. It uses same components as PB010 valve, with excellent control in a wide flow and pressure range. The steel body is designed for heavy duty applications. Pressure setting at least 1.3 times the load induced pressure.

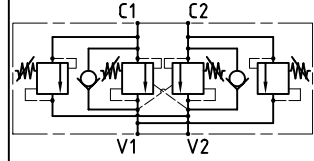
Dieses Ventil ist durch seine kompakten Maße und seine gute Toleranz bezüglich einer eventuellen Ölverschmutzung gekennzeichnet. Es besteht aus den gleichen Komponenten wie das Ventil PB010. Dank seines Stahlgehäuses ist dieses Ventil auch für schwere Anwendungen geeignet. Sehr gute Kontrolle innerhalb eines weiten Volumenstrom- und Druckbereiches. Druckeinstellung 1.3x Ladedruck.

**TECHNICAL DATA
TECHNISCHE ANGABEN**

Max operating pressure Maximaler Betriebsdruck	21 MPa-2987 psi (Alloy/Aluminium) 35 MPa-5076 psi (Zincoated Steel/Verzink. Stahl)
Max flow Volumenstrom	25 l/min 6.6 gpm
Temperature range Betriebstemperatur	-20°/80°C
Filtration Filtergrad	40µ

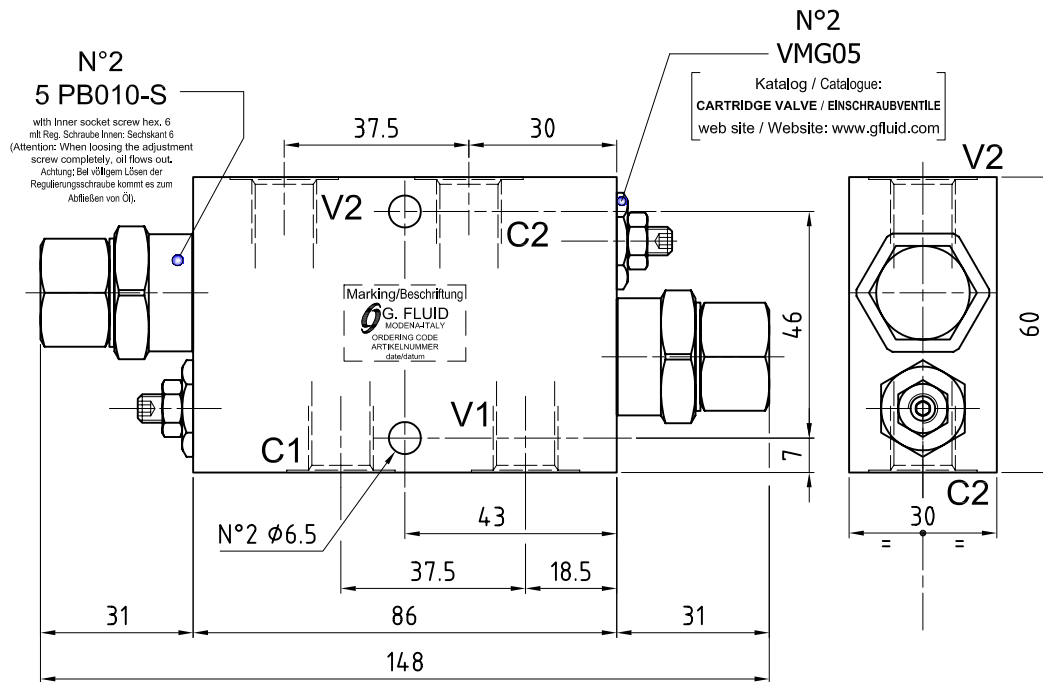
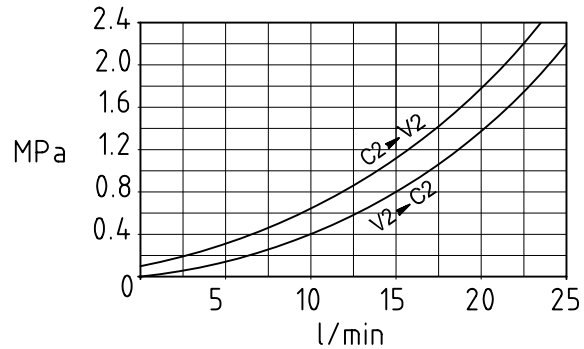
ORDERING CODE - ARTIKELNUMMER
144152

06	Pilot ratio Steuerverhältnis	4:1	2	Adj. range Regelbereich	10-35 MPa	std setting Standardeinst.	30 MPa	Pressure increase MPa/turn Drucksteigerung MPa je Schraubendrehung	11.6	01	Port size/Gewinde V1, V2, C1, C2	G 1/4"	0	Material Material	AlloyAluminium	Weight Gewicht	0.6 kg	Description Bezeichnung	VBG-DE-2VM-25-A
													1	Zincoated Steel/ Verzinkter Stahl		2.7 kg		VBG-DE-2VM-25-S	

GVA-50-52

TECHNICAL DATA
TECHNISCHE ANGABEN

Max operating pressure Maximaler Betriebsdruck	21 MPa-2987 psi (Alloy/Aluminium) 35 MPa-5076 psi (Zincoated Steel/Verzink. Stahl)
Max flow Volumenstrom	40 l/min 10.6 gpm
Temperature range Betriebstemperatur	-20°/80°C
Filtration Filtergrad	40µ

Relief setting: at least 1.3 times the highest expected load.
 Einstellung Druckbegrenzungsventil: mindestens 1,3 x der höchsten zu erwartenden Last.

The lower pressure setting refers to flow from C1 to C2 (or C2 to C1), and is adjustable through register A (see the drawing).
 Die niedrigere Druckeinstellung bezieht sich auf den Durchfluß von C1 nach C2 (oder C2 zu C1) und ist durch den Regler A (siehe Zeichnung) einstellbar.

Diagram/Diagramm

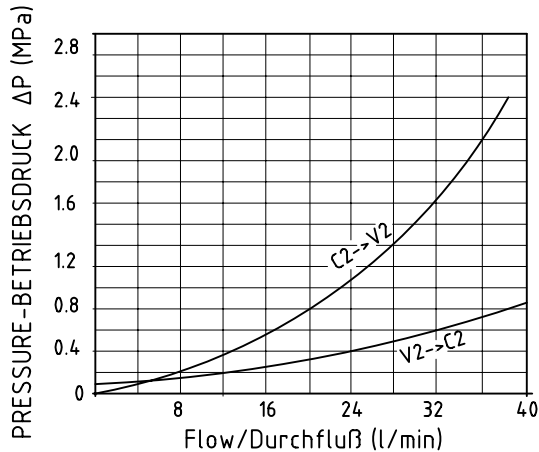
PORT SIZE
GEWINDE

T, C1, C2, V1, V2 G 3/8"

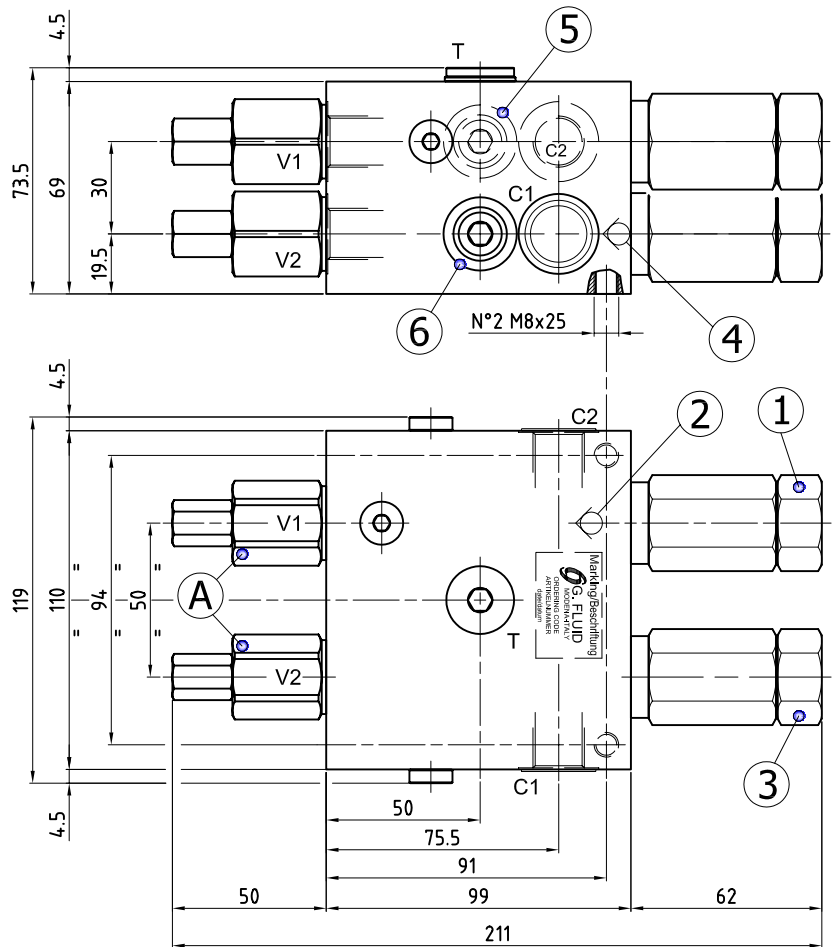
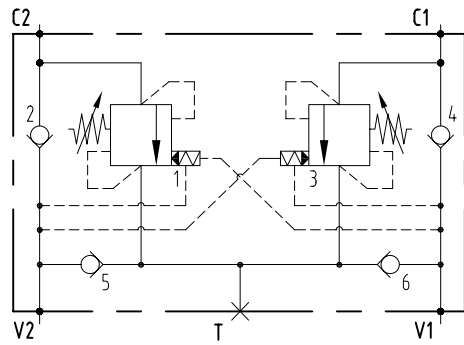
ORDERING CODE - ARTIKELNUMMER
20535521 02 0

Pilot ratio Versteuerverhältnis	Adj. range Regelbereich	std setting Standardeinst.	Pressure increase MPa/turn Drucksteigerung MPa je Schraubendrehung	A Lower pressure setting niedrigere Druckeinstellung	Material Material	Description Bezeichnung	Weight Gewicht
5 9:1	1 6-21 MPa	20 MPa	6.0	9.0	1 Alloy/Aluminium	GVA-50-52-A	3.4 kg
	2 10-35 MPa	30 MPa	10.0	12.0	2 Zincoated Steel Verzinkter Stahl	GVA-50-52-S	9.5 kg
					3 Alloy (black anodized) Aluminium (schwarz eloxiert)	GVA-50-52-AN	3.4 kg

GVA-120-53-S

TECHNICAL DATA TECHNISCHE ANGABEN

Max operating pressure Maximaler Betriebsdruck	35 MPa 5076 psi
Max flow Volumenstrom	120 l/min 31.7 gpm
Temperature range Betriebstemperatur	-20°/80°C
Filtration Filtergrad	40µ

Relief setting: at least 1.3 times the highest expected load.
Einstellung Druckbegrenzungsventil: mindestens 1,3 x der höchsten zu erwartenden Last.

The lower pressure setting refers to flow from C1 to C2 (or C2 to C1), and is adjustable through register A (see the drawing).
Die niedrigere Druckeinstellung bezieht sich auf den Durchfluß von C1 nach C2 (oder C2 zu C1) und ist durch den Regler A (siehe Zeichnung) einstellbar.

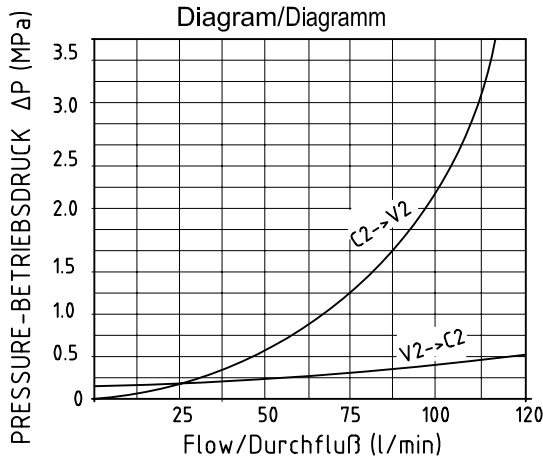

PORT SIZE GEWINDE

C1, C2, V1, V2	G 3/4"
T	G 1/2"
C3	G 1/4"

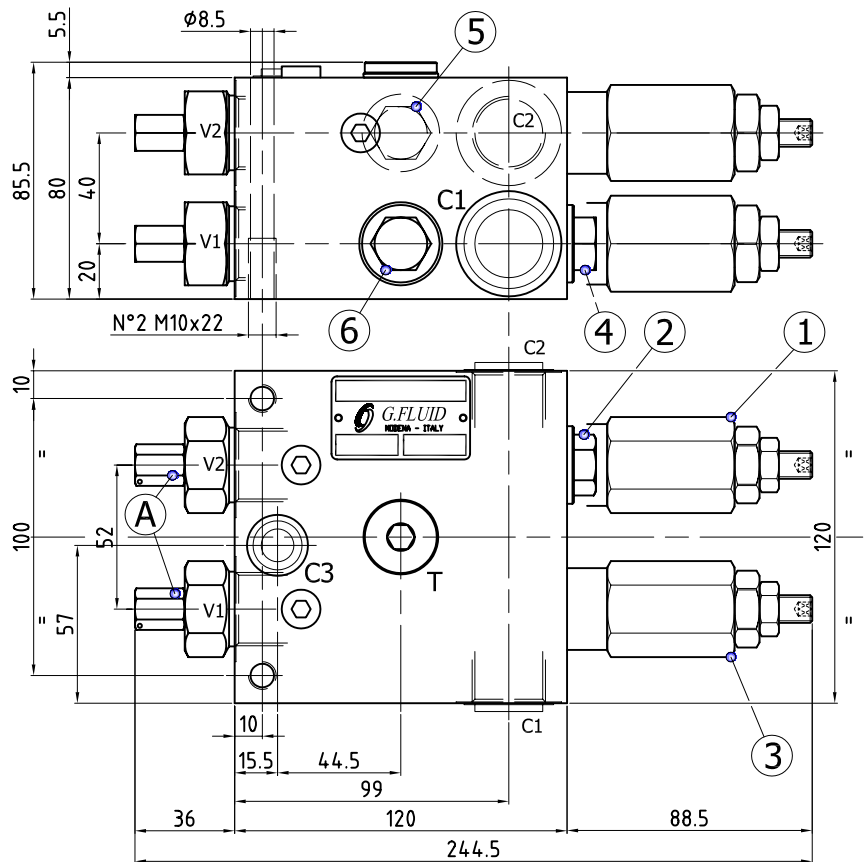
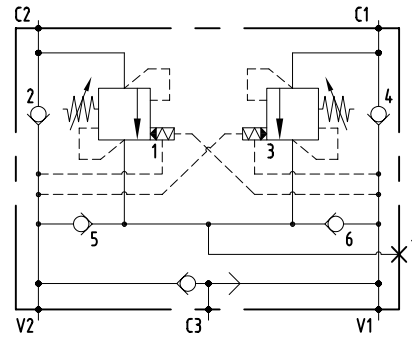

ORDERING CODE - ARTIKELNUMMER

20535532 04 0

3 6	Pilot ratio Versteuerverhältnis	1 2	Adj. range Regelbereich	std setting Standardeinst.	Pressure increase MPa/turn Drucksteigerung MPa je Schraubendrehung	A Lower pressure setting niedrigere Druckeinstellung	2	Material Material	Description Bezeichnung	Weight Gewicht
	7.6:1 4:1		6-21 MPa 10-35 MPa	20 MPa 30 MPa	6.5 6.5	9.0 12.0		Zincoated Steel Verzinkter Stahl	GVA-120-53-S	6.5 kg

GVA-120-53-ST-S

TECHNICAL DATA TECHNISCHE ANGABEN

Max operating pressure Maximaler Betriebsdruck	35 MPa 5076 psi
Max flow Volumenstrom	120 l/min 31.7 gpm
Temperature range Betriebstemperatur	-20°/80°C
Filtration Filtergrad	40µ

Relief setting: at least 1.3 times the highest expected load.
 Einstellung Druckbegrenzungsventil: mindestens 1,3 x der höchsten zu erwartenden Last.

The lower pressure setting refers to flow from C1 to C2 (or C2 to C1), and is adjustable through register A (see the drawing).
 Die niedrigere Druckeinstellung bezieht sich auf den Durchfluß von C1 nach C2 (oder C2 zu C1) und ist durch den Regler A (siehe Zeichnung) einstellbar.

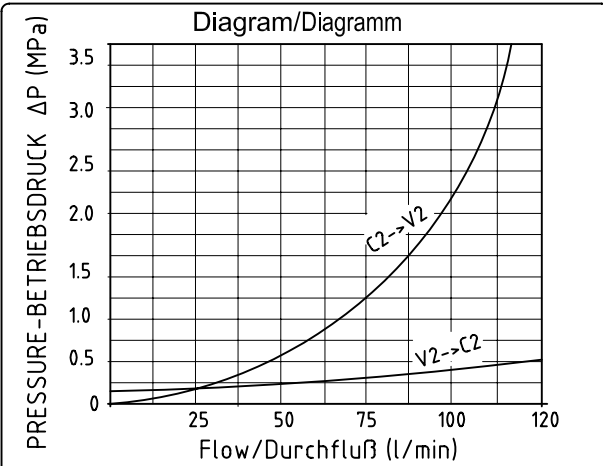

PORT SIZE GEWINDE

C1, C2, V1, V2	G 3/4"
T	G 1/2"
C3	G 1/4"

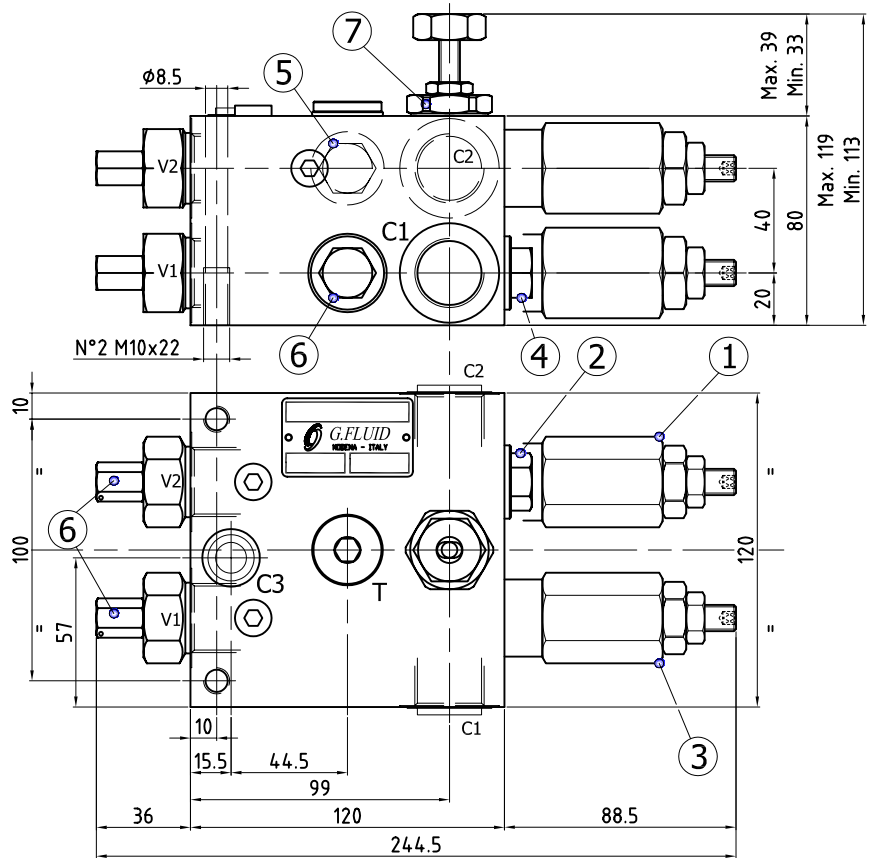
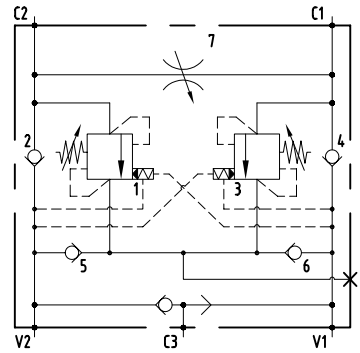

ORDERING CODE - ARTIKELNUMMER

20535532 04 1

	Pilot ratio Versteuerverhältnis	Adj. range Regelbereich	std setting Standardeinst.	Pressure increase MPa/turn Drucksteigerung MPa je Schraubendrehung	A Lower pressure setting niedrigere Druckeinstellung	Material Material	Description Bezeichnung	Weight Gewicht
3	7.6:1	1 6-21 MPa	20 MPa	6.5	9.0	2 Zincoated Steel Verzinkter Stahl	GVA-120-53-ST-S	6.5 kg
6	4:1	2 10-35 MPa	30 MPa	6.5	12.0			

GVA-120-53-ST-10-S

TECHNICAL DATA TECHNISCHE ANGABEN

Max operating pressure Maximaler Betriebsdruck	35 MPa 5076 psi
Max flow Volumenstrom	120 l/min 31.7 gpm
Temperature range Betriebstemperatur	-20°/80°C
Filtration Filtergrad	40μ

Relief setting: at least 1.3 times the highest expected load.
Einstellung Druckbegrenzungsventil: mindestens 1,3 x der höchsten zu erwartenden Last.

The lower pressure setting refers to flow from C1 to C2 (or C2 to C1), and is adjustable through register A (see the drawing).
Die niedrigere Druckeinstellung bezieht sich auf den Durchfluß von C1 nach C2 (oder C2 zu C1) und ist durch den Regler A (siehe Zeichnung) einstellbar.

Diagram/Diagramm

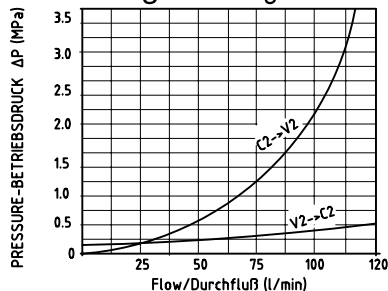

PORT SIZE GEWINDE

C1, C2, V1, V2	G 3/4"
T	G 1/2"
C3	G 1/4"

ADJUSTMENT OPTIONS EINSTELLUNG

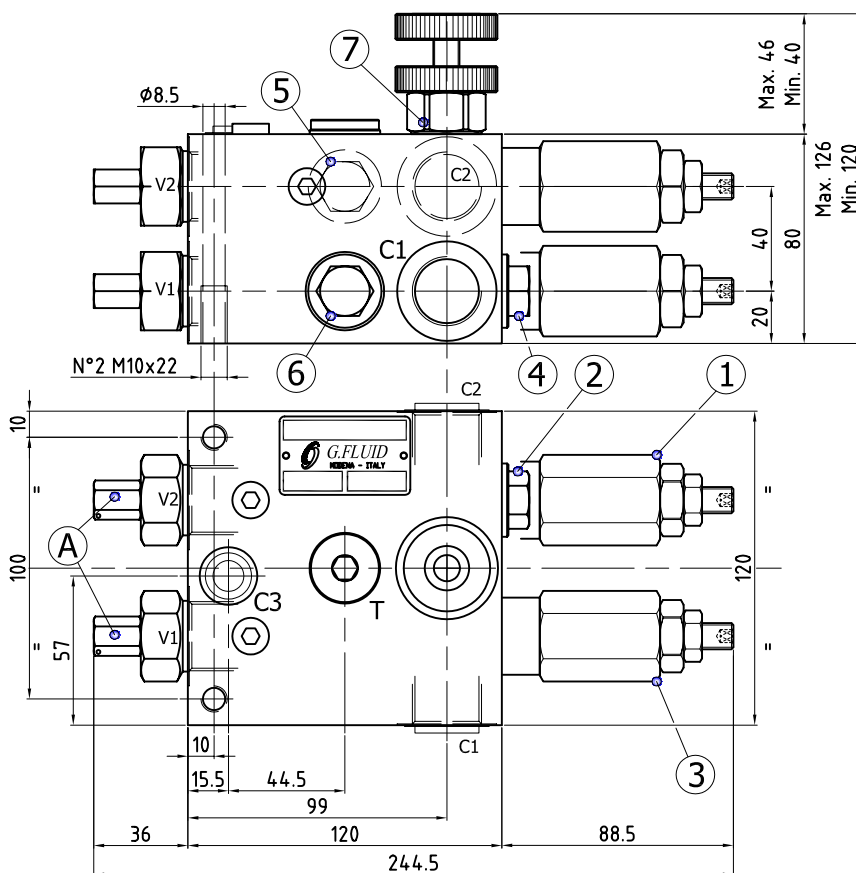
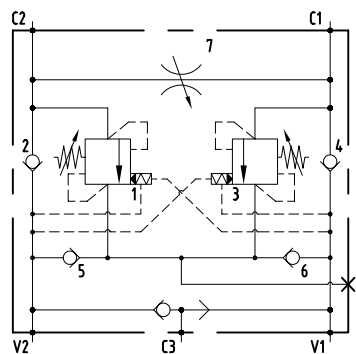
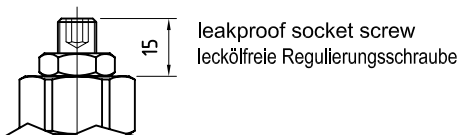

ORDERING CODE - ARTIKELNUMMER

20535542 04

	Pilot ratio Verstärkerverhältnis	Adj. range Regelbereich	std setting Standardeinst.	Pressure increase MPa/turn Drucksteigerung MPa je Schraubendrehung	A Lower pressure setting niedrigere Druckeinstellung	Material Material	Weigth Gewicht	Adjustment options Einstellung
3	7.6:1	1	20 MPa	6.5	9.0	2	6.5 kg	2 handknob and locknut Handrad und Mutter
6	4:1	2	30 MPa	6.5	12.0			3 leakproof socket screw leackölfreie Regulierungsschraube

**TECHNICAL DATA
 TECHNISCHE ANGABEN**

Max operating pressure Maximaler Betriebsdruck	21 MPa-2987 psi (Alloy/Aluminium) 35 MPa-5076 psi (Zincoated Steel/Verzinkt. Stahl)
Max flow Volumenstrom	200 l/min 53 gpm
Temperature range Betriebstemperatur	-20°/80°C
Filtration Filtergrad	40µ

Relief setting: at least 1.3 times the highest expected load.
 Einstellung Druckbegrenzungsventil: mindestens 1,3 x der höchsten zu erwartenden Last.

The lower pressure setting refers to flow from C1 to C2 (or C2 to C1), and is adjustable through register A (see the drawing).
 Die niedrigere Druckeinstellung bezieht sich auf den Durchfluß von C1 nach C2 (oder C2 zu C1) und ist durch den Regler A (siehe Zeichnung) einstellbar.

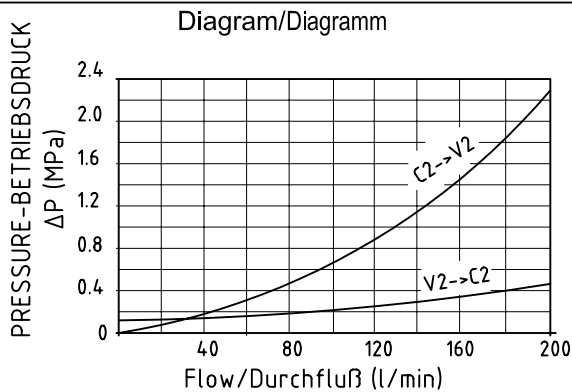
**PORT SIZE
 GEWINDE**

C1, C2, V1, V2	G 1"
T	G 5/8"
C3	G 1/4"

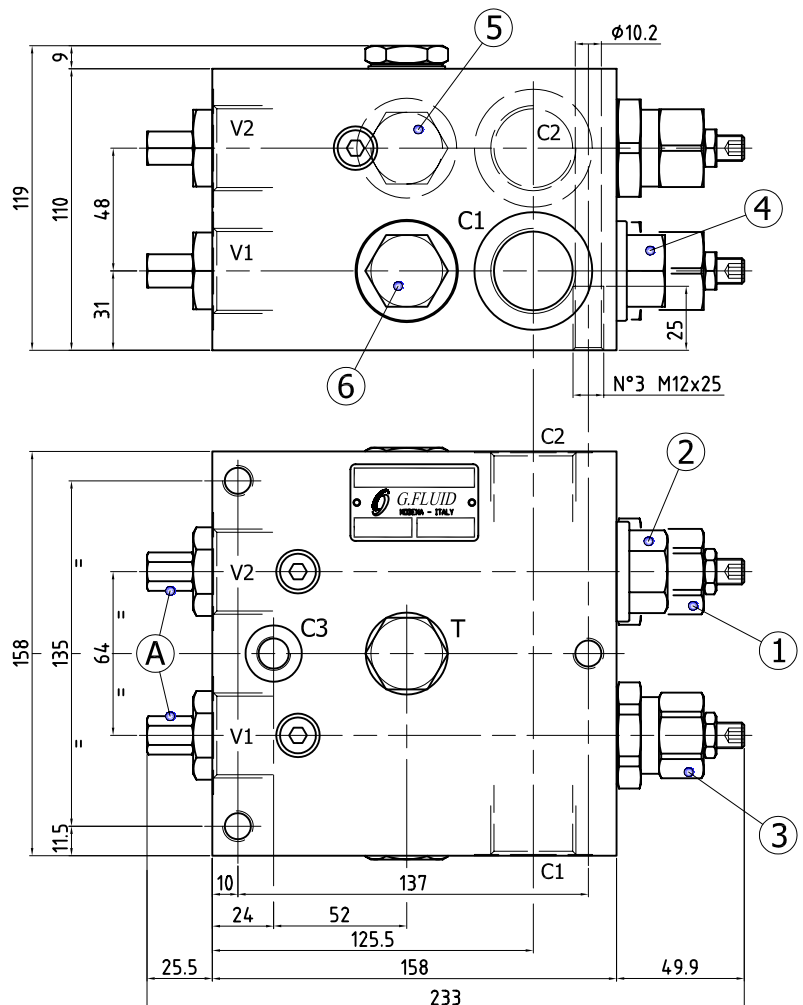
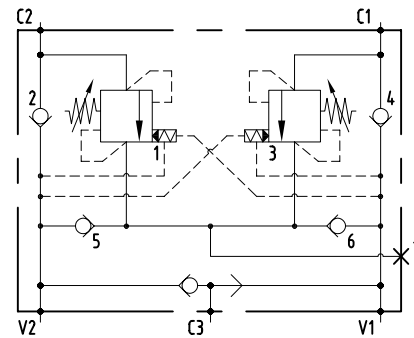

ORDERING CODE - ARTIKELNUMMER
20536533 05 0

4	Pilot ratio Versteuerverhältnis	8:1	2	Adj. range Regelbereich	10-35 MPa	std setting Standardeinst.	30 MPa	Pressure increase MPa/turn Drucksteigerung MPa je Schraubendrehung	4.4	A Lower pressure setting niedrigere Druckeinstellung	12.0	1	Material Material	Alloy/Aluminium	Description Bezeichnung	GVA-200-53-A	Weight Gewicht	9.0 kg
												2	Zincoated Steel Verzinkter Stahl	GVA-200-53-S			23.0 kg	

GLM-3PS-20-12-S

TECHNICAL DATA
TECHNISCHE ANGABEN

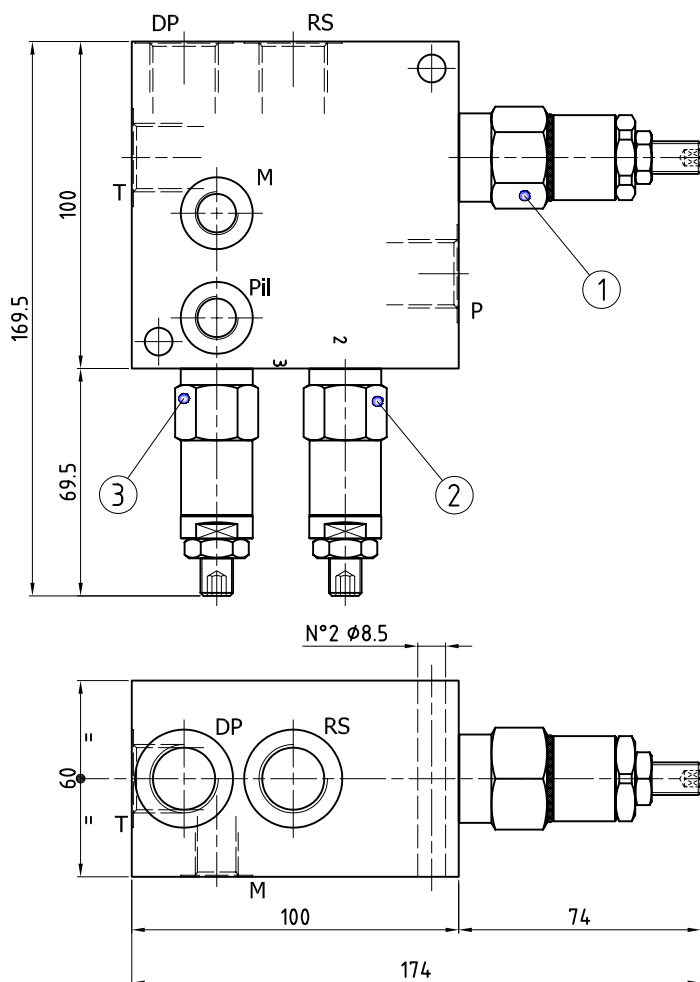
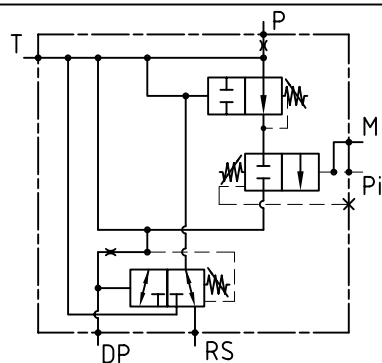
Max operating pressure Maximaler Betriebsdruck	35 MPa 5076 psi
Max flow Volumenstrom	20 l/min 5.3 gpm
Temperature range Betriebstemperatur	-20°/80°C
Filtration Filtergrad	40µ
Weight Gewicht	4.8 kg
Material Material	Zinc coated Steel Verzinkter Stahl

PORT SIZE
GEWINDE

T, DP, P, RS	G 1/2"
Pil, M	G 1/4"

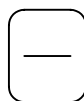
ORDERING INSTRUCTIONS - BESTELLANLEITUNG
25 00 21 13
-

-
1 00 00

Spring Feder	Standard setting Standardkalibrierung
4 10-21 MPa	(20 MPa)

**TECHNICAL DATA
TECHNISCHE ANGABEN**

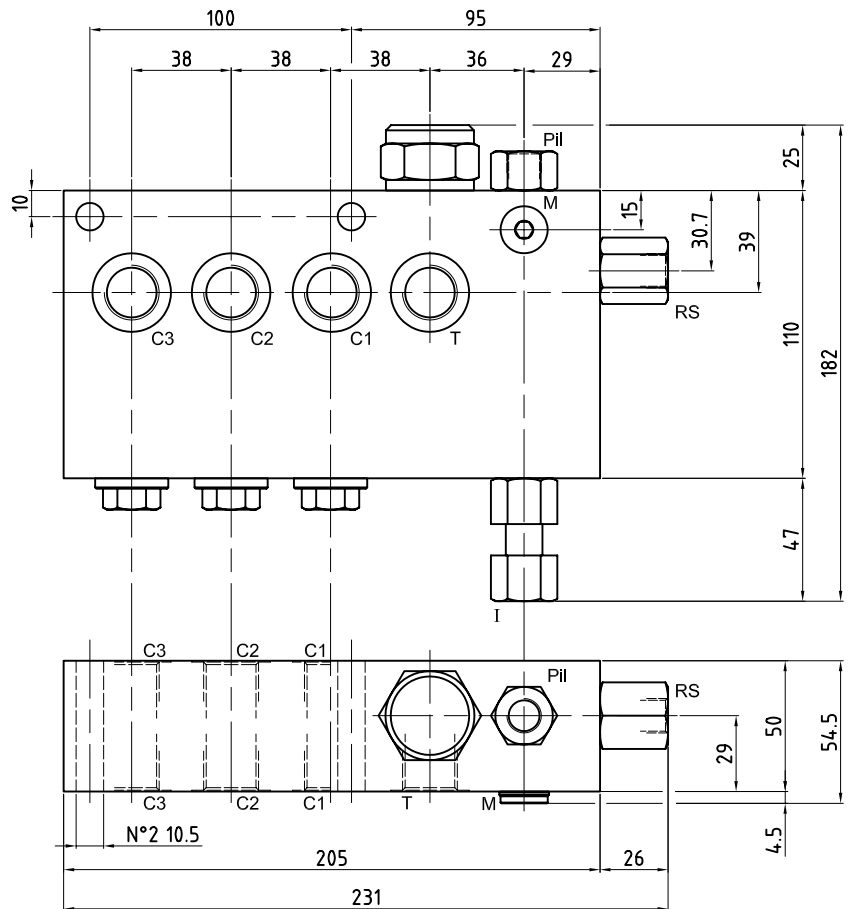
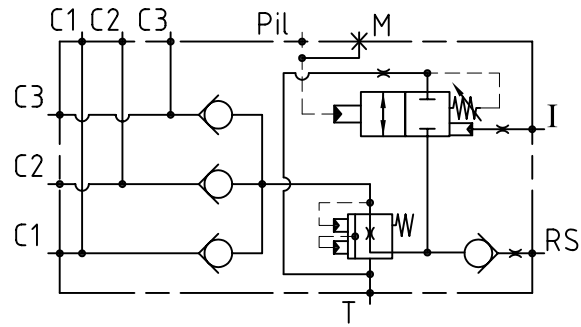
Max operating pressure Maximaler Betriebsdruck	35 MPa 5076 psi
Max flow Volumenstrom	60 l/min 15.8 gpm
Temperature range Betriebstemperatur	-20°/80°C
Filtration Filtergrad	40µ
Weight Gewicht	8.0 kg
Material Material	Zincoated Steel Verzinkter Stahl

**PORT SIZE
GEWINDE**

C1, C2, C3, T	G 1/2"
Piil, RS, M, I	G 1/4"

ORDERING INSTRUCTIONS - BESTELLANLEITUNG
25 00 11 33
-

-
1 00 00

 Spring
Feder

5 | 10-35 MPa

 Standard setting
Standardkalibrierung
(20 MPa)

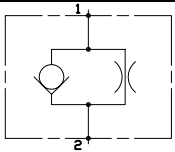
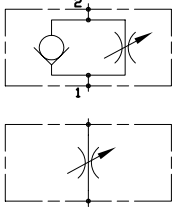
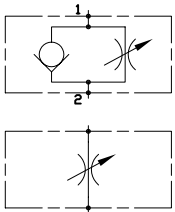
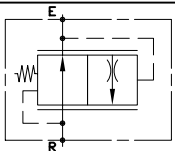
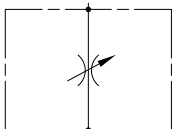
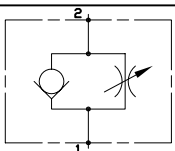
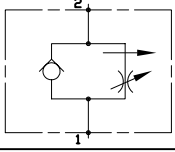
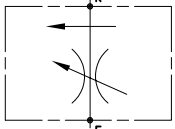
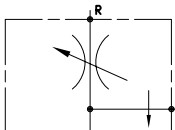
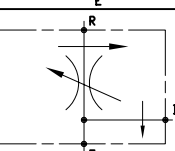
Scheme Schema	Description Bezeichnung	max flow max Durchfluß	max pressure max Arbeitsdruck	page Seite
	GVU-18-MF14	12 l/min 3.2 gpm	35 MPa 5076 psi	3.001.01
	GLR-___ GLS-___	100 l/min 26.4 gpm	35 MPa 5076 psi	3.001.02
	FR116 FR138 FR016 FR038	30 l/min 7.9 gpm	35 MPa 5076 psi	3.001.03
	FRC14	10 l/min 2.6 gpm	25 MPa 3626 psi	3.001.04
	GTS-___	15-30-50 l/min 3.9-7.9-13.2 gpm	40 MPa 5081 psi	3.001.05
	GTR-___	15-30-50 l/min 3.9-7.9-13.2 gpm	40 MPa 5081 psi	3.001.06
	GTC-___	10-18-33 l/min 2.6-4.8-8.7 gpm	25 MPa 3626 psi	3.001.11
	GRF2-10 GRF2-12	20-30 l/min 5.3-3.9 gpm 55-90 l/min 14.5-23.8 gpm	35 MPa 5076 psi	3.009.01 3.009.02
	GRF3-10 GRF3-12	20-30 l/min 5.3-3.9 gpm 90-150 l/min 23.8-39.6 gpm	35 MPa 5076 psi	3.010.01 3.010.02
	GRF3C-12	90-150 l/min 23.8-39.6 gpm	35 MPa 5076 psi	3.011.02

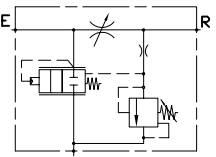
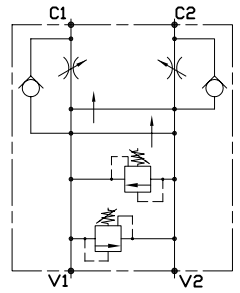
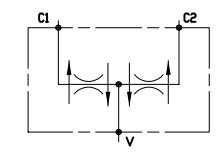
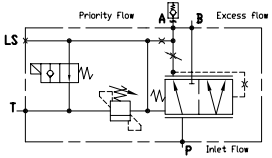
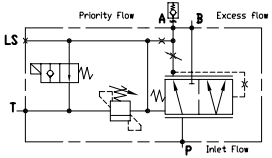
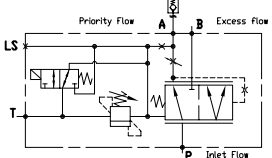
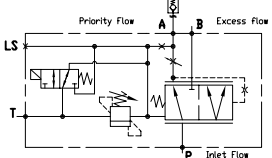
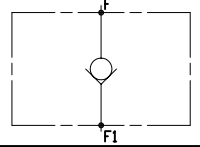
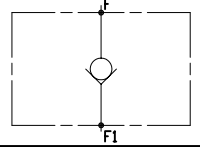
Scheme Schema	Description Bezeichnung	max flow max Durchfluß	max pressure max Arbeitsdruck	page Seite
	GRF3-VM-34	150 l/min 39.6 gpm	21 MPa 2987 psi	3.015.02
	GRF3-DE-VU-34-___	150 l/min 39.6 gpm	35 MPa 5076 psi	3.016.02
	GDF 38-12 GDF 34-100 GDF16__ - GDF16F	6-11-22 l/min 1.6-2.9-5.8 gpm 150 l/min 39.6 gpm 4-8-16-32-50 l/min 1.6-2.9-5.8 gpm 6-11-22 l/min 1.1-2.2-4.2-8.4- 13.2 gpm	35 MPa 5076 psi	3.020.01 3.020.02 3.020.03 3.020.04
	GRF-SA-PM-12	85 l/min 22.4 gpm	35 MPa 5076 psi	3.090.01
	GRF-SA-PM-34	140 l/min 36.9 Gpm	35 MPa 5076 psi	3.091.01
	GRF-SA-PM-100	220 l/min 58 gpm	35 MPa 5076 psi	3.092.01
	GRF-SA-PM-144	300 l/min 79.2 gpm	35 MPa 5076 psi	3.092.02
	GVU-MF	300 l/min 79.2 gpm	35 MPa 5076 psi	3.099.01
	GFPR	300 l/min 79.2 gpm	35 MPa 5076 psi	3.099.05

Unidirectional 2 ways flow control valve:

- free flow from port 2 to 1
- fixed orifice from 1 to 2

2-Wege-Stromregelventil:

- ermöglicht Durchfluss von 2 nach 1
- fixer Bohrungsdurchmesser von 1 nach 2

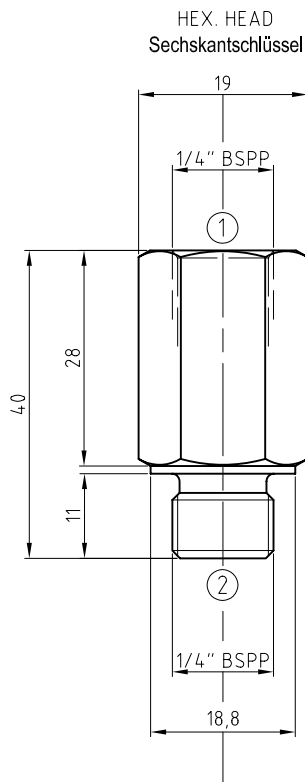
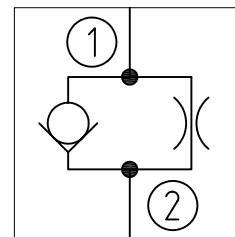

**TECHNICAL DATA
TECHNISCHE ANGABEN**

Max operating pressure Maximaler Betriebsdruck	35 MPa 5076 psi
Max inflow Volumenstrom	12 l/min 3.2 gpm
Weight Gewicht	0.10 kg 0.22 lb
Temperature range Betriebstemperatur	-40°/120°C
Filtration Filtergrad	25 µm (page/Seite A.01.01-1)

**TABLE A
TABELLE A**

X	Orifice Bohrungsdurchmesser
0	without - ohne
A	Ø 0.5
B	Ø 0.8
C	Ø 0.9
D	Ø 1.0
E	Ø 1.1
F	Ø 1.2
G	Ø 1.3
H	Ø 1.4
I	Ø 1.5
L	Ø 1.6

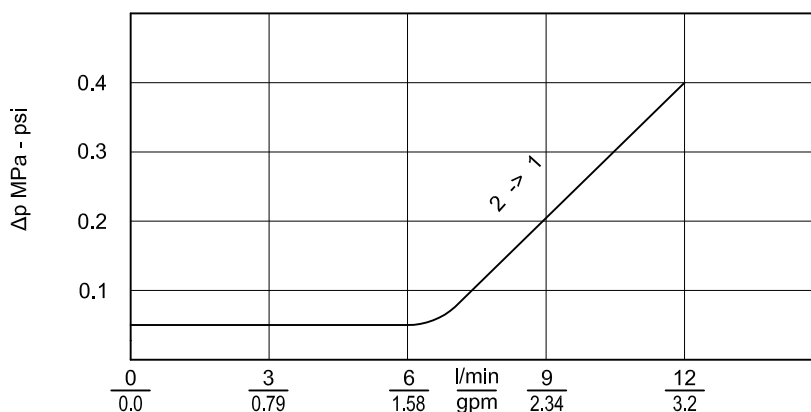

ORDERING INSTRUCTIONS - BESTELLANLEITUNG

11 11 02 **X**8 12 00

X	Orifice Bohrungsdurchmesser
0	see table A - siehe Tabelle A
A	...
B	...

**TECHNICAL DATA
 TECHNISCHE ANGABEN**

Max operating pressure Maximaler Betriebsdruck	35 MPa 5076 PSI
Max flow Volumenstrom	see table/siehe Tabelle
Temperature range Betriebstemperatur	-20°/80°C
Filtration Filtergrad	40μ

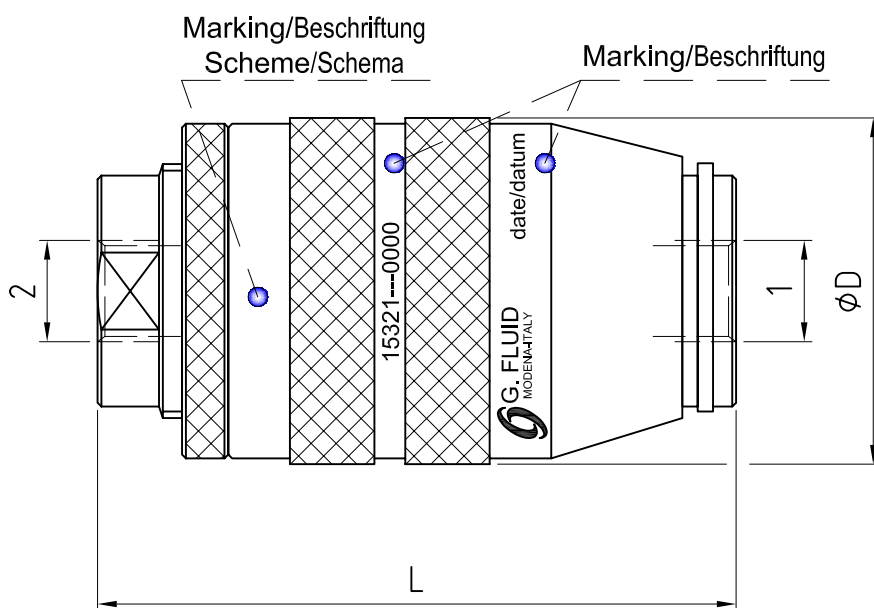
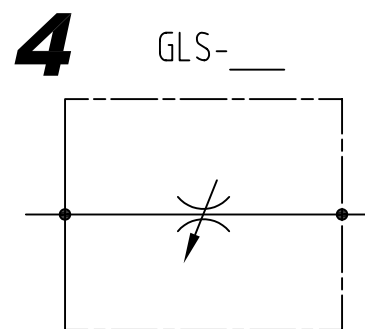
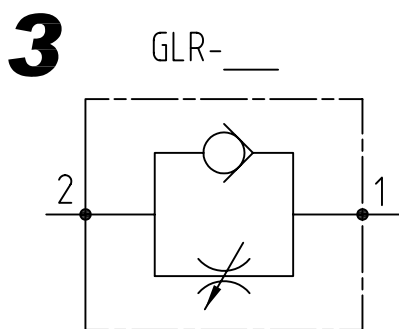
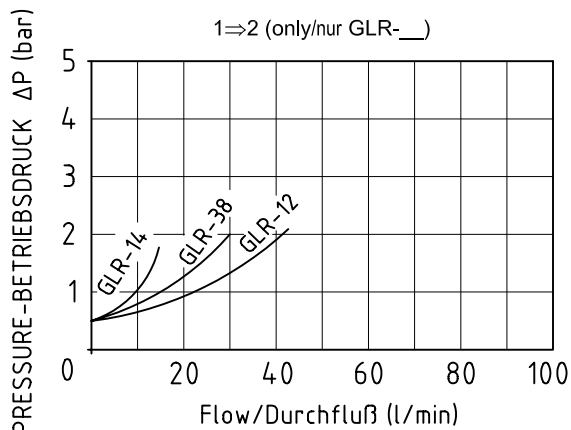
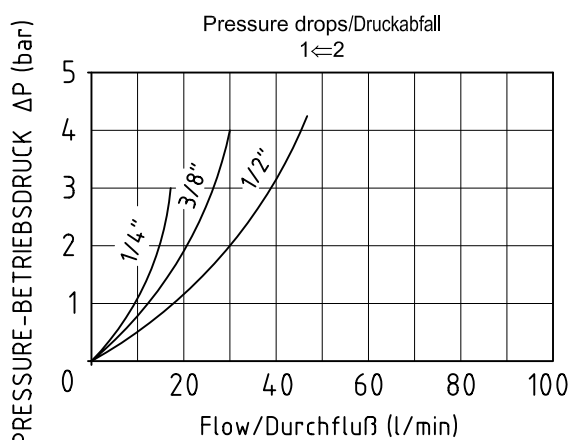
Diagram/Diagramm

Description Bezeichnung	Max flow Volumenstrom	1, 2	L	ØD	Weigh Gewicht
GLR-14 / GLS-14	15 l/min - 3.9 gpm	1/4" bspp	62	34	0.23 kg
GLR-38 / GLS-38	30 l/min - 7.9 gpm	3/8" bspp	73	40	0.42 kg
GLR-12 / GLS-12	45 l/min - 11.9 gpm	1/2" bspp	83	45	0.66 kg

ORDERING INSTRUCTIONS - BESTELLANLEITUNG
15321

-

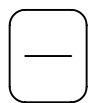

Scheme/Schema

3 | GLR-__
4 | GLS-__

-

 Port size/Gewinde
1, 2

01 | 1/4" bspp (GLR-14)
02 | 3/8" bspp (GLR-38)
03 | 1/2" bspp (GLR-12)

-

0000

Flow regulator:
-high modularity
-easy setting

2-Wege-Drosselventil:
-hohe Kompatibilität
-einfacher Einbau

FR016/FR038

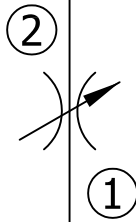

Unidirectional
2 ways flow
control valve:
-easy setting
-free flow from
port 2 to 1

2-Wege-Stromregelventil
mit
Umgehungs-Rückschlagventil:
-einfacher Einbau
-ermöglicht Durchfluss
von 2 nach 1

FR116/FR138

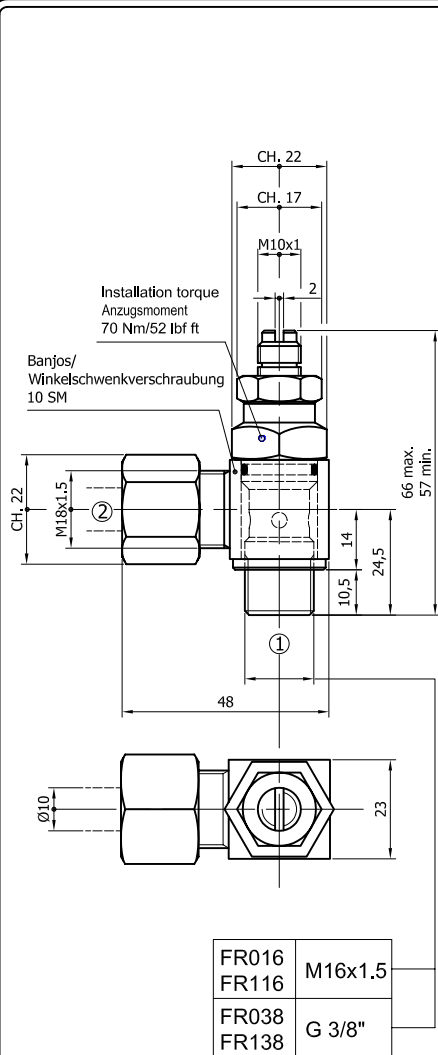
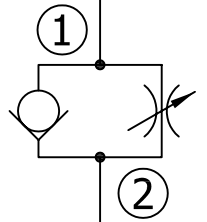
TECHNICAL DATA
TECHNISCHE ANGABEN

Max operating pressure Maximaler Betriebsdruck	25 MPa 3626 psi
Flow setting Geregelter Durchfluß	30 l/min 7.9 gpm
Leakage Leckölstrom	0.2 cc/min
Weight Gewicht	0.2 kg 0.44 lb
Filtration Filtergrad	25 µm

ACCESSORIES
ZUBEHÖR

ORDERING CODE - ARTIKELNUMMER
6FR **00000** **00**

Internal G.Fluid number/Interne G.Fluid Nummer

Update/Aktualisierte Version

0 Needle valve 2-Wege-Drosselventil Unidirectional flow control valve/ Stromregelventil	Valve type Ventiltyp	16 M16x1.5 38 G 3/8"	Thread Gewinde	N00 NBR 70 V00 VITON	Seal type Dichtungstyp	Temperature range Betriebstemperatur -30°÷125°C -25°÷230°C
---	-------------------------	---------------------------------------	-------------------	---------------------------------------	---------------------------	---

Flow from E to R: compensated flow
Flow from R to E: not compensated flow,
pressure drop depends on the size of
calibrated orifice
Flow can be adjusted by turning the nut.

Durchfluss von E nach R: kompensiert
Durchfluss von R nach E: nicht kompensiert,
Druckabfall hängt von der Grösse des Normallochs ab.

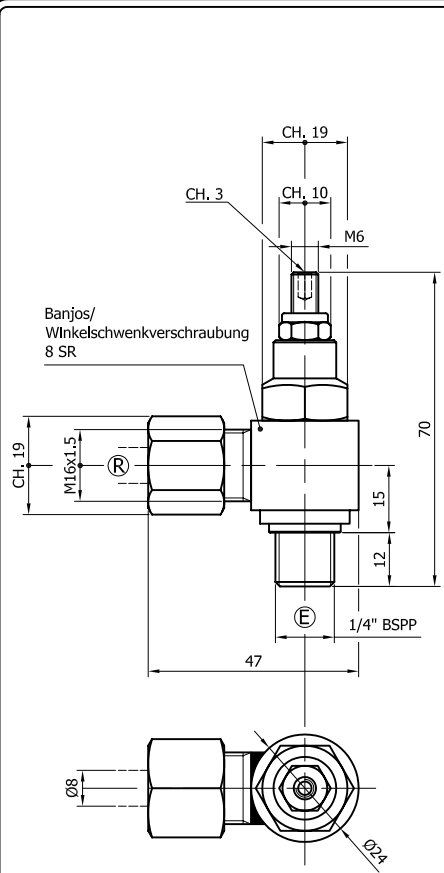
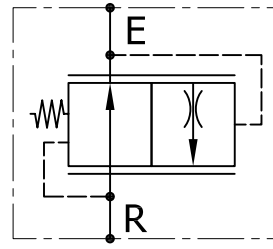

TECHNICAL DATA TECHNISCHE ANGABEN	
Max operating pressure Maximaler Betriebsdruck	25 MPa 3626 psi
Flow setting Geregelter Durchfluß	10 l/min 2.6 gpm
Leakage Leckölstrom	0.2 cc/min
Weight Gewicht	0.2 kg 0.44 lb
Installation torque Anzugsmoment	39 Nm 29 lbf ft
Filtration Filtergrad	25 µm (page/Seite A.01.01-1)

ACCESSORIES ZUBEHÖR	

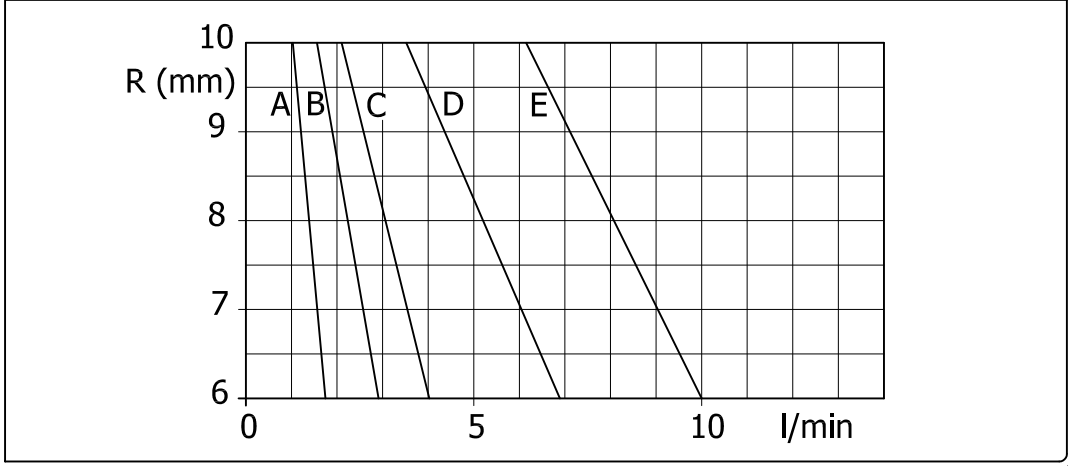

ORDERING INSTRUCTIONS - BESTELLANLEITUNG

FRC14 - [] - [] - []

Valve code
Ventil Bestellnummer

Regulated Flow Geregelter Durchfluß		Type Typ	Seal type Dichtungstyp		Temperature range Betriebstemperatur
A	1+1.6 l/min	08	N	NBR 93	-30°+120°C
B	1.6+2.5 l/min			VITON	-15°+220°C
C	2.5+4.0 l/min				
D	4.0+6.3 l/min				
E	6.3+10 l/min				

**TECHNICAL DATA
 TECHNISCHE ANGABEN**

Max operating pressure Maximaler Betriebsdruck	40 MPa 5081 PSI
Max flow Volumenstrom	see table/siehe Tabelle
Temperature range Betriebstemperatur	-20°/80°C
Filtration Filtergrad	40µ

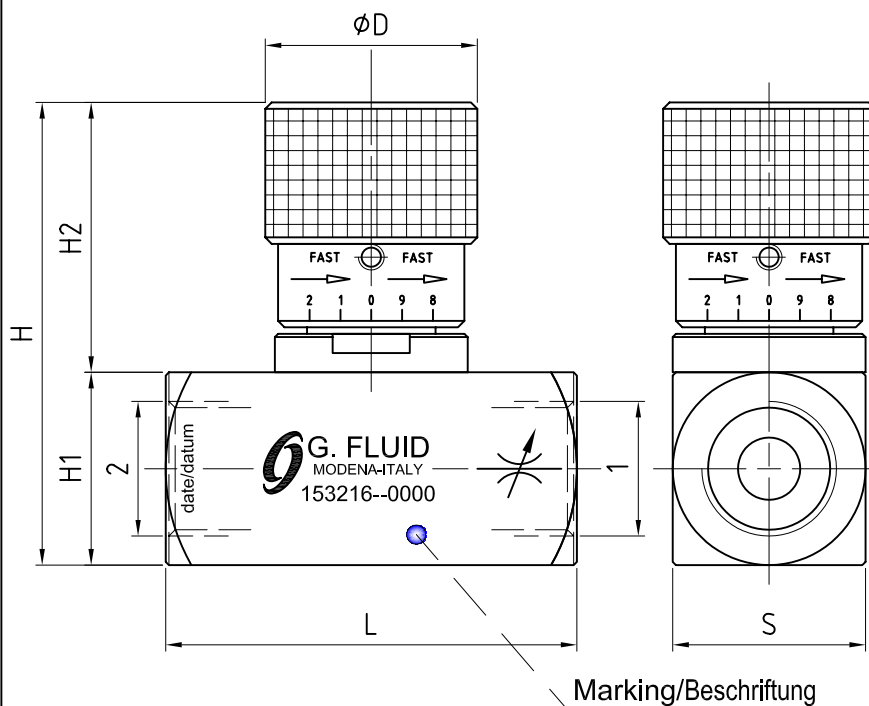
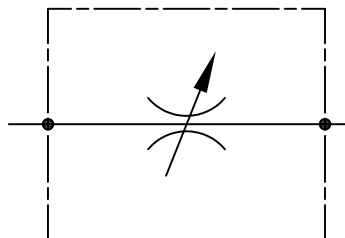
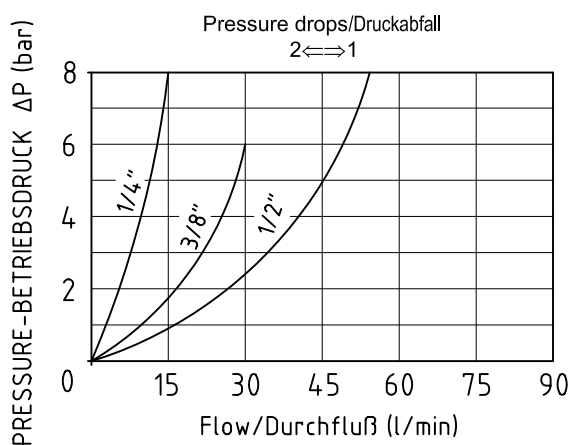
Diagram/Diagramm

Description Bezeichnung	Max flow Volumenstrom	1, 2	L	H1	H2	H	S	ØD	Weigth Gewicht
GTS-14	15 l/min - 3.9 gpm	1/4" bspp	54	25	43	68	25	30	0.3 kg
GTS-38	30 l/min - 7.9 gpm	3/8" bspp	54	25	43	68	25	30	0.3 kg
GTS-12	50 l/min - 13.2 gpm	1/2" bspp	64	30	42	72	30	33	0.45 kg

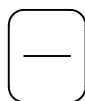
ORDERING INSTRUCTIONS - BESTELLANLEITUNG
153216
-

-
0000

 Port size/Gewinde
 1, 2

01	1/4" bspp (GTS-14)
02	3/8" bspp (GTS-38)
03	1/2" bspp (GTS-12)

TECHNICAL DATA
TECHNISCHE ANGABEN

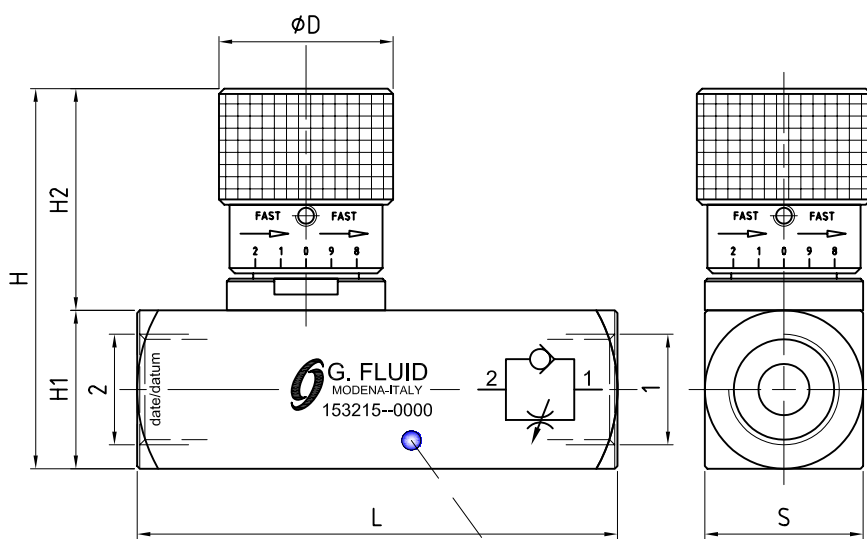
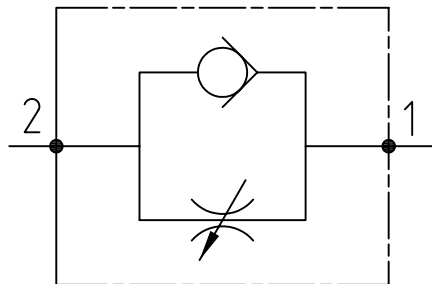
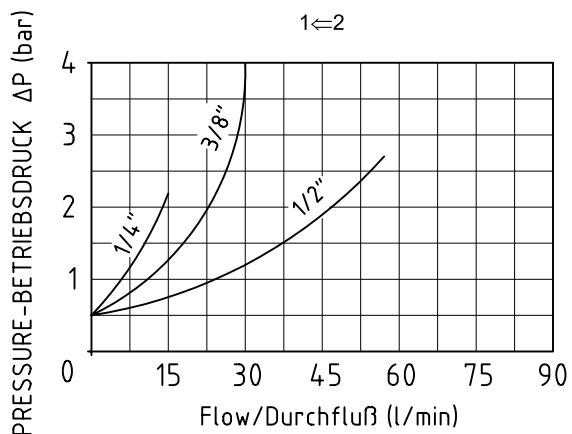
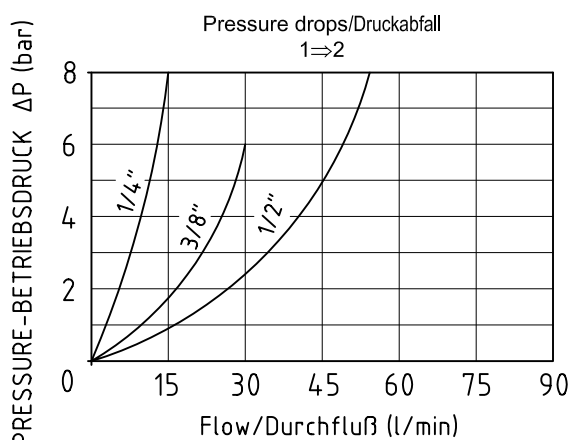
Max operating pressure Maximaler Betriebsdruck	40 MPa 5081 PSI
Max flow Volumenstrom	see table/siehe Tabelle
Temperature range Betriebstemperatur	-20°/80°C
Filtration Filtergrad	40µ

Diagram/Diagramm

Marking/Beschriftung

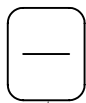
Description Bezeichnung	Max flow Volumenstrom	1, 2	L	H1	H2	H	S	ØD	Weigh Gewicht
GTR-14	15 l/min - 3.9 gpm	1/4" bspp	66	25	43	68	25	30	0.37 kg
GTR-38	30 l/min - 7.9 gpm	3/8" bspp	71	25	43	68	25	30	0.38 kg
GTR-12	50 l/min - 13.2 gpm	1/2" bspp	91	30	42	72	30	33	0.6 kg

ORDERING INSTRUCTIONS - BESTELLANLEITUNG
153215
-

-
0000

 Port size/Gewinde
 1, 2

01	1/4" bspp (GTR-14)
02	3/8" bspp (GTR-38)
03	1/2" bspp (GTR-12)

**TECHNICAL DATA
TECHNISCHE ANGABEN**

Max operating pressure Maximaler Betriebsdruck	25 MPa 3626 PSI
Max flow Volumenstrom	see table/siehe Tabelle
Temperature range Betriebstemperatur	-20°/80°C
Filtration Filtergrad	40μ

Diagram/Diagramm

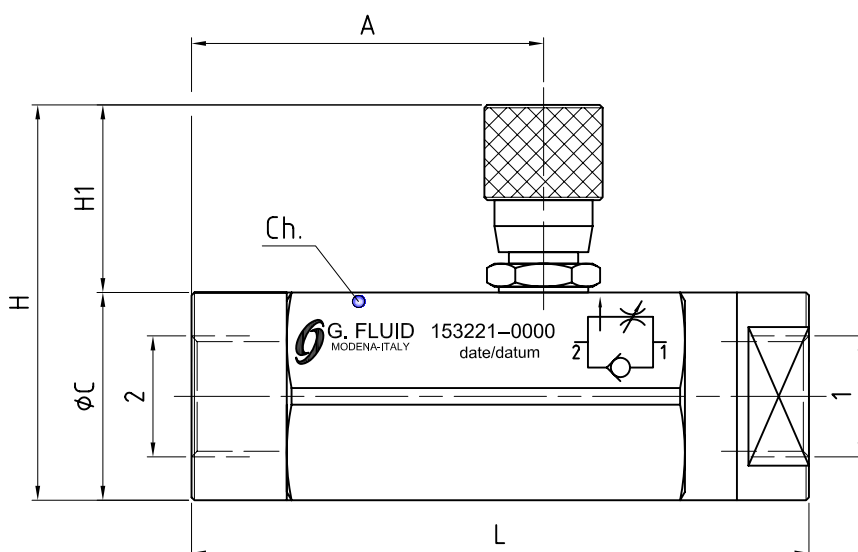
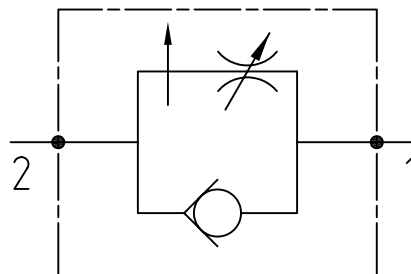
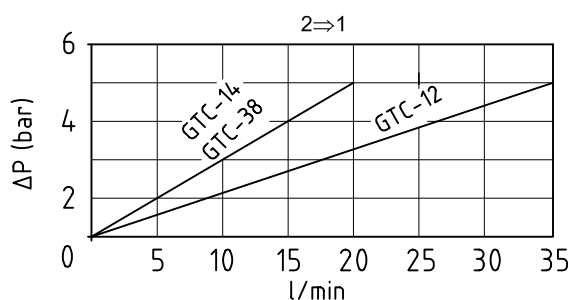
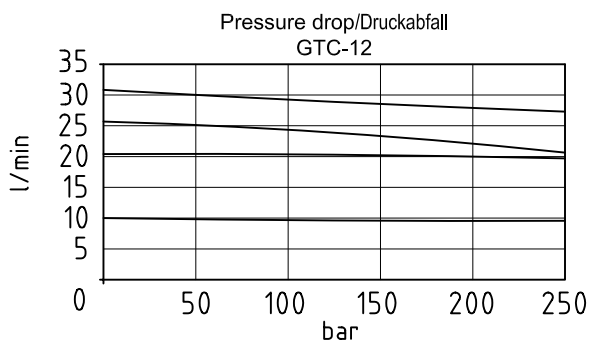
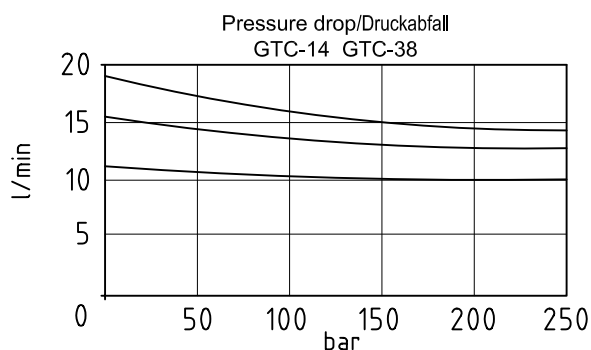

Description Bezeichnung	Max flow Volumenstrom	1, 2	L	H1 min	H1 max	H min	H max	A	ØC Ch.	Weigth Gewicht
GTC-14	10 l/min - 2.6 gpm	1/4" bspp	88					51	27	0.34 kg
GTC-38	18 l/min - 4.8 gpm	3/8" bspp	88	32.5	37	59.5	64	51	27	0.34 kg
GTC-12	33 l/min - 8.7 gpm	1/2" bspp	108			68.5	73	61	36	0.70 kg

ORDERING INSTRUCTIONS - BESTELLANLEITUNG

153221

-

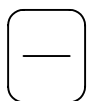

-

0000

Port size/Gewinde
1, 2

- 01** 1/4" bspp (GTC-14)
- 02** 3/8" bspp (GTC-38)
- 03** 1/2" bspp (GTC-12)

GRF2-10

Pressure compensated flow regulator valve.
It keeps outlet flow from port "R" constant and independent from pressure changes.
Flow from E to R: pressure compensated
Flow from R to E: not compensated
Kompensator: LCA10

Druckkompensiertes Stromregelventil. Der Strom von R wird konstant gehalten und ist unabhängig von Druckschwankungen.
Durchfluss von E nach R: kompensiert
Durchfluss von R nach E: nicht kompensiert
Kompensator: LCA10

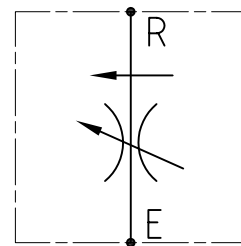

TECHNICAL DATA TECHNISCHE ANGABEN

Max operating pressure Maximaler Betriebsdruck	25 MPa: Aluminium 35 MPa: Steel / Stahl
Max. inflow (= reg. flow) Max. Zulaufölstrom (=ger. Ölstrom)	1/4" BSPP: 20 l/min 3/8" BSPP: 30 l/min
Weight Gewicht	0.6 kg (Aluminium) 1.0 kg (Steel / Stahl)
Temperature range Betriebstemperatur	-20°/80°C
Filtration Filtergrad	10µ

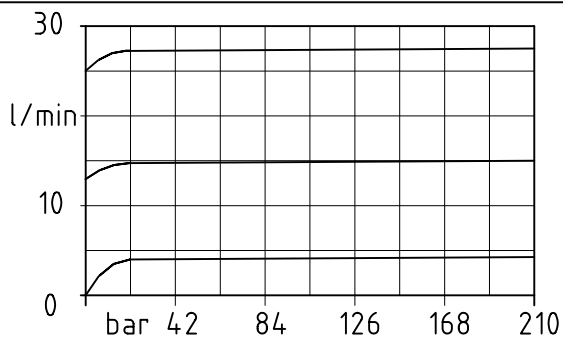

leakproof socket screw
leckölfreie Reguliierungsschraube

handknob
Handrad

hex. head
Sechskantschlüssel

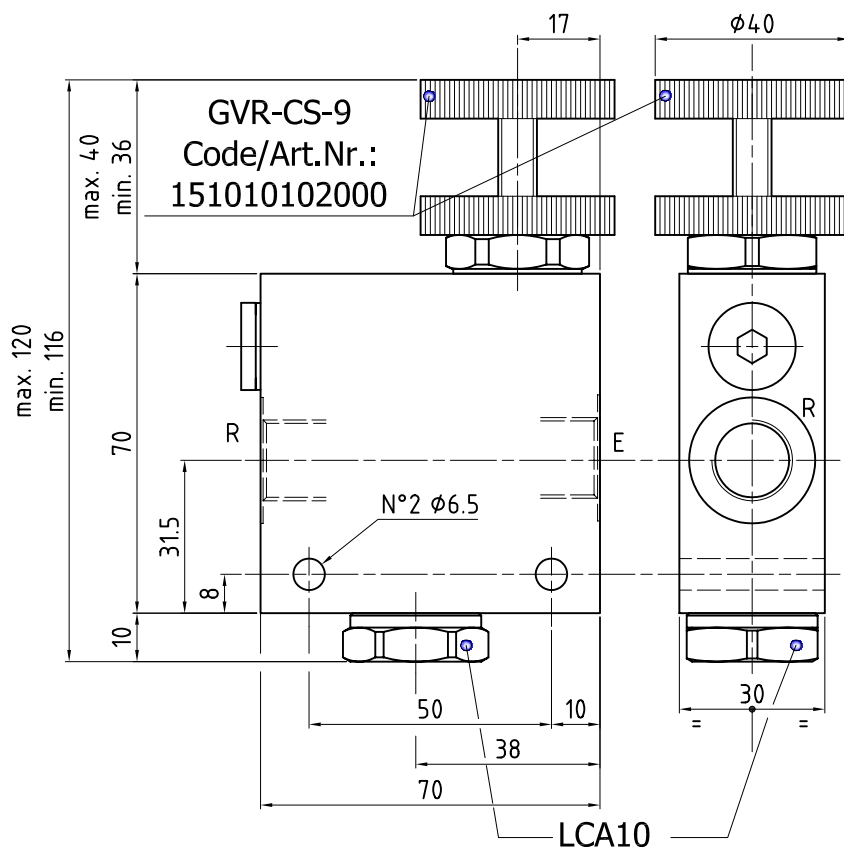
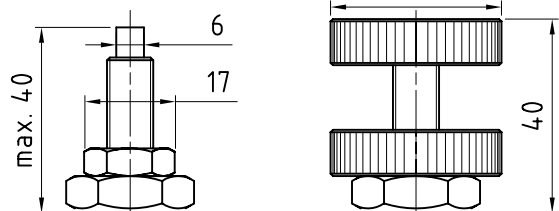

Seite / Page Katalog / Catalogue
L.05.01-1 GFC001-10-03

ORDERING INSTRUCTIONS - BESTELLANLEITUNG

15 41 21 01 1 -- -

Port size - Gewinde E, R	↑	↑	Material Material
1/4" BSPP	01	0	Alloy / Aluminium
3/8" BSPP	02	1	Steel / Stahl

Pressure compensated flow regulator valve.
It keeps outlet flow from port "R" constant and independent from pressure changes.
Flow from E to R: pressure compensated
Flow from R to E: not compensated
Compensator: VCA316G

Druckkompensiertes Stromregelventil. Der Strom von R wird konstant gehalten und ist unabhängig von Druckschwankungen.
Durchfluss von E nach R: kompensiert
Durchfluss von R nach E: nicht kompensiert
Kompensator: VCA316G

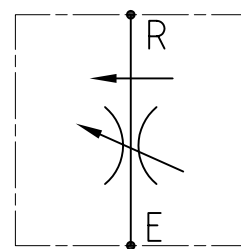

TECHNICAL DATA TECHNISCHE ANGABEN

Max operating pressure Maximaler Betriebsdruck	25 MPa: Aluminium 35 MPa: Steel / Stahl
Max. inflow (= reg. flow) Max. Zulaufölstrom (=ger. Ölstrom)	1/2" BSPP: 55 l/min 3/4" BSPP: 90 l/min
Weight Gewicht	1.0 kg (Aluminium) 3.0 kg (Steel / Stahl)
Temperature range Betriebstemperatur	-20°/80°C
Filtration Filtergrad	10µ

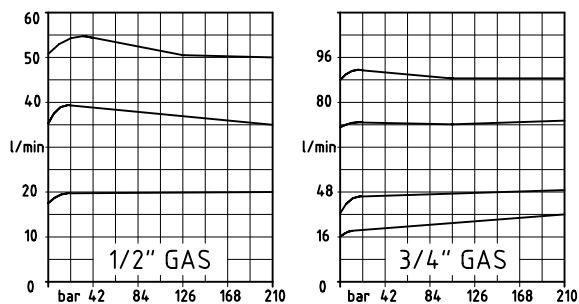

leakproof socket screw
leckölfreie Regulierungsschraube

handknob
Handrad

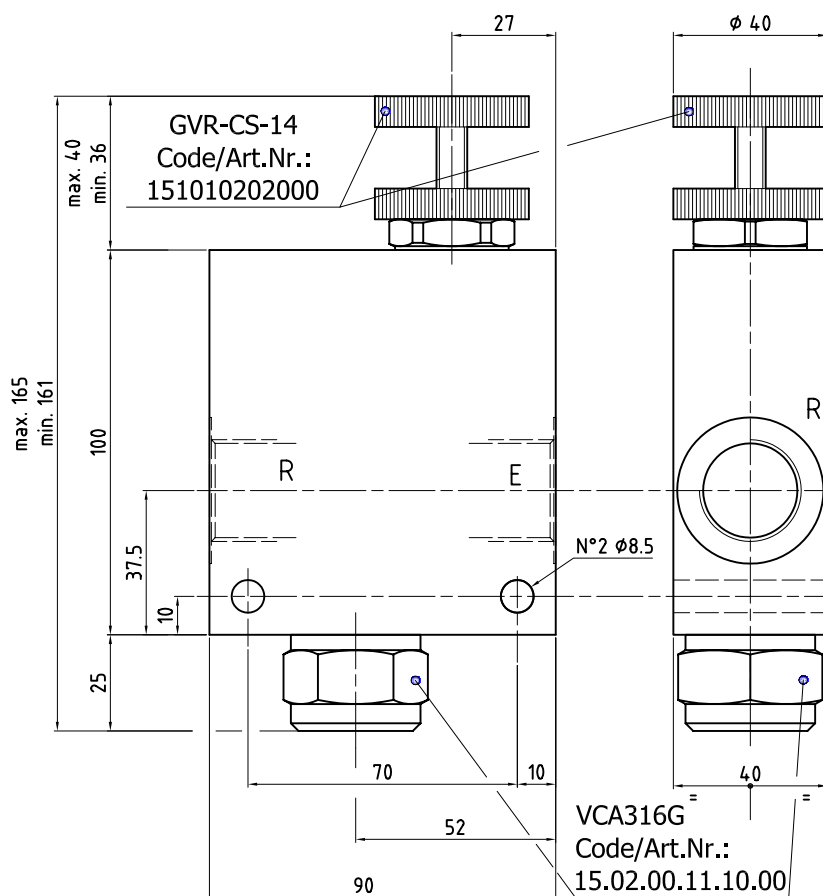
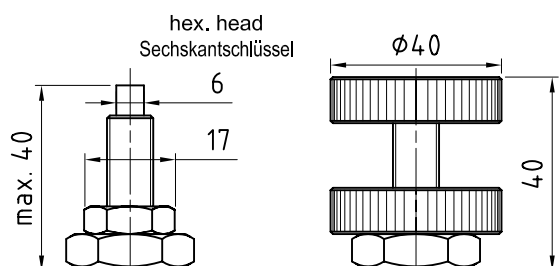

ORDERING INSTRUCTIONS - BESTELLANLEITUNG

15 41 21 01 1 -- -

Port size - Gewinde E, R			Material Material
1/2" BSPP	03	0	Alloy / Aluminium
3/4" BSPP	04	1	Steel / Stahl

GRF3-10

Pressure compensated flow regulator valve.
It keeps outlet flow from port "R" constant and independent from pressure changes.
Excess flow to tank "T".
Kompensator: LCC10

Druckkompensiertes Stromregelventil. Der Strom von R wird konstant gehalten und ist unabhängig von Druckschwankungen.
Der Überschuss wird zum Tank geleitet.
Kompensator: LCC10

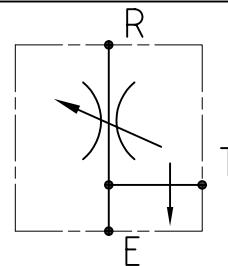

TECHNICAL DATA TECHNISCHE ANGABEN

Max operating pressure Maximaler Betriebsdruck	25 MPa: Aluminium 35 MPa: Steel / Stahl
Max flow inlet (port E) Eingangs-Volumenstrom (gewinde E)	1/4" BSPP: 30 l/min 3/8" BSPP: 50 l/min
Max flow delivery (port R) Anfangs-Volumenstrom (gewinde R)	1/4" BSPP: 20 l/min 3/8" BSPP: 30 l/min
Weight Gewicht	0.6 kg (Aluminium) 1.0 kg (Steel / Stahl)
Temperature range Betriebstemperatur	-20°/80°C
Filtration Filtergrad	40µ

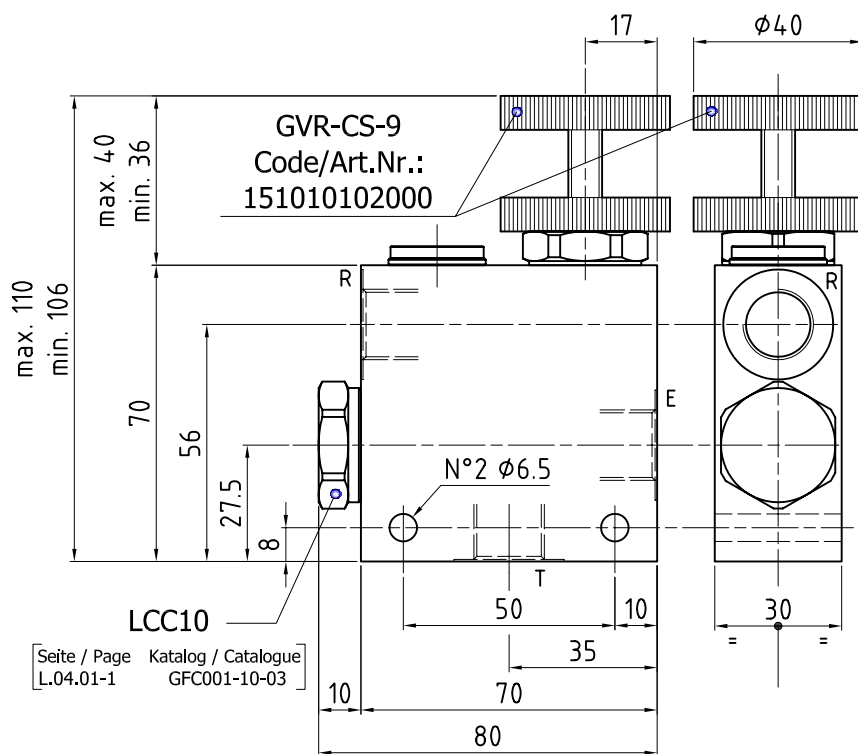
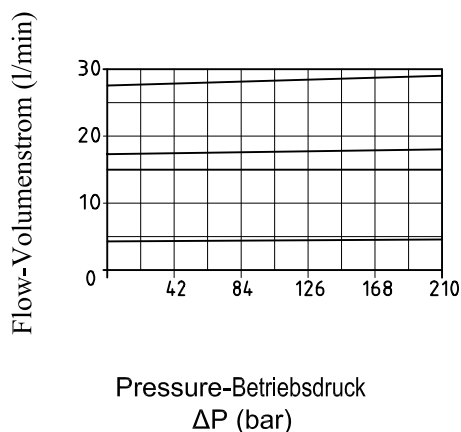

ORDERING INSTRUCTIONS - BESTELLANLEITUNG

15 41 22 02 2 -- -

Port size - Gewinde E, R, T	↑	↑	Material Material
1/4" BSPP	01	0	Alloy / Aluminium
3/8" BSPP	02	1	Steel / Stahl

GRF3-12

Pressure compensated flow regulator valve.
It keeps outlet flow from port "R" constant and independent from pressure changes.
Excess flow to tank "T".
Compensator: VCC316G

Druckkompensiertes Stromregelventil. Der Strom von R wird konstant gehalten und ist unabhängig von Druckschwankungen.
Der Überschuss wird zum Tank geleitet.
Kompensator: VCC316G

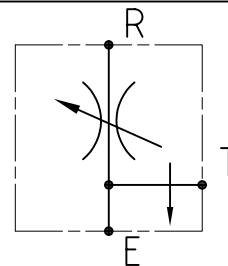

TECHNICAL DATA TECHNISCHE ANGABEN

Max operating pressure Maximaler Betriebsdruck	21 MPa / 2987 psi: Alloy / Aluminium 35 MPa / 5076 psi: Steel / Stahl
Max flow inlet (port E) Eingangs-Volumenstrom (gewinde E)	1/2" BSPP: 90 l/min 3/4" BSPP: 150 l/min
Max flow delivery (port R) Ansgangs-Volumenstrom (gewinde R)	1/2" BSPP: 55 l/min 3/4" BSPP: 90 l/min
Temperature range Betriebstemperatur	-20°/80°C
Filtration Filtergrad	40µ

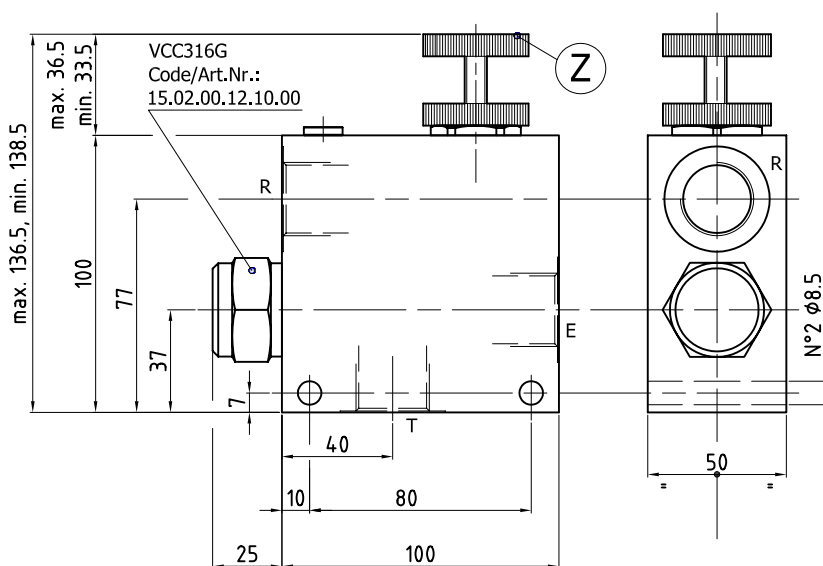
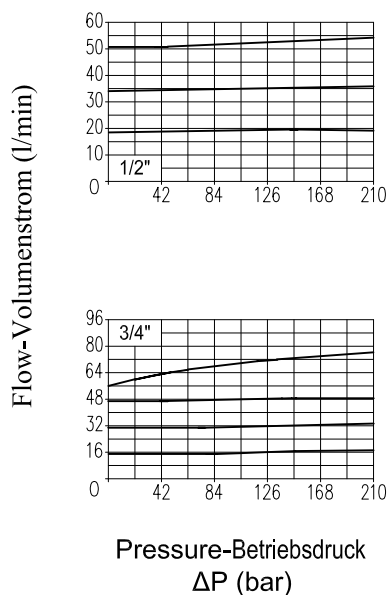

Valve - Ventil Z	Code - Art. Nr.	Port size - Gewinde E, R, T
GVR-CS-9	15.10.10.10.20.00	1/2" BSPP
GVR-CS-14	15.10.10.20.20.00	3/4" BSPP

ORDERING CODE - ARTIKELNUMMER

154122022

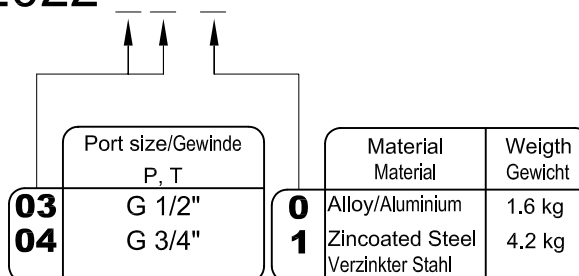

Pressure compensated flow regulator valve.
It keeps outlet flow from port "P" constant and independent from pressure changes at port P or B.
Excess flow to port "B".
Kompensator: LC112

Druckkompensiertes Stromregelventil. Der Strom von P wird konstant gehalten und ist unabhängig von Druckschwankungen in P oder B.
Der Überschuss wird nach B geleitet.
Kompensator: LC112

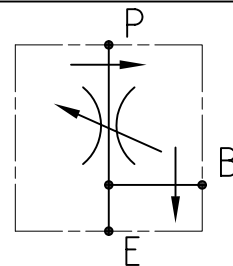

TECHNICAL DATA TECHNISCHE ANGABEN

Max operating pressure Maximaler Betriebsdruck	21MPa / 2987psi: Alloy / Aluminium 35MPa / 5076psi: Steel / Stahl
Max flow inlet (port E) Eingangs-Volumenstrom (Anschluß E)	1/2" BSPP: 90 l/min 3/4" BSPP: 150 l/min
Max flow delivery (port R) Ausgangs-Volumenstrom (Anschluß R)	1/2" BSPP: 55 l/min 3/4" BSPP: 90 l/min
Temperature range Betriebstemperatur	-20°/80°C
Filtration Filtergrad	40µ

Diagram/Diagramm

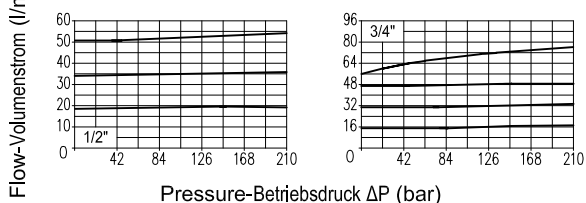

Adjustment options/Einstellung

0: leakproof socket screw
leckölfreie Regulierungsschraube

2: handwheel
Handrad

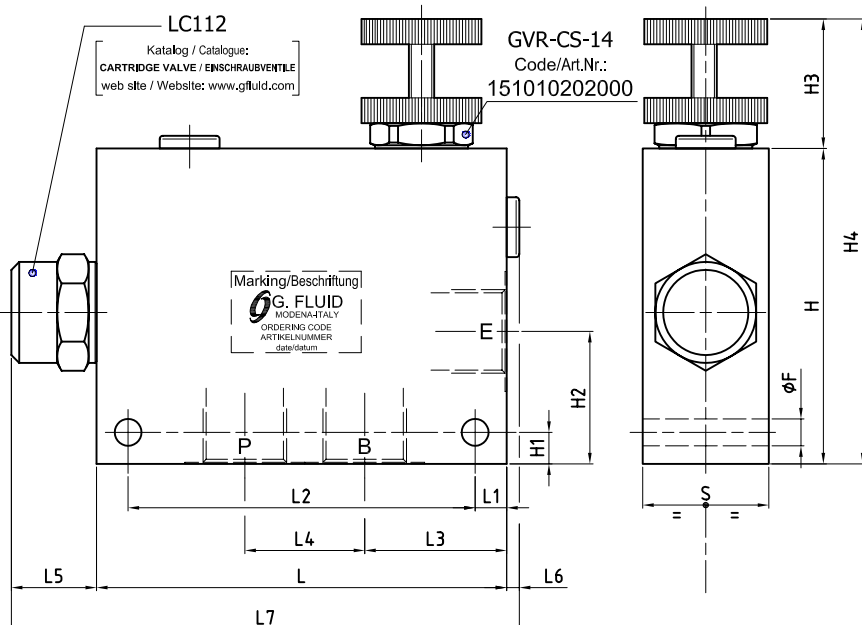
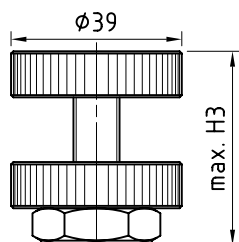
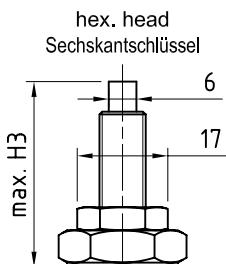

P-B-E	L	L1	L2	L3	L4	L5	L6	L7	S	H	H1	H2	H3	H4	F
1/2" G	130	10	110	47.5	32	27	4	161	40	100	10	42	41	141	8.5
3/4" G	130	10	110	45	38	27	4	161	40	100	10	42	41	141	8.5

ORDERING CODE - ARTIKELNUMMER

15412204

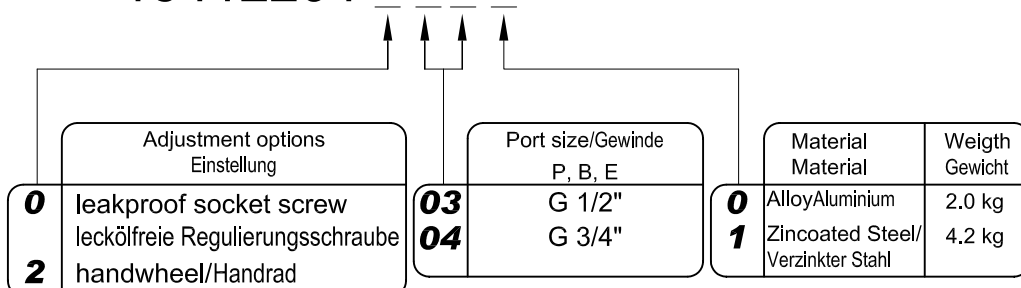

GRF3-VM-34

Pressure compensated flow regulator valve.
 It keeps outlet flow from port "R" constant and independent from pressure changes.
 Excess flow to tank "T".
 Compensator: VCC316G
 Relief: VMG05

Druckkompensiertes Stromregelventil. Der Strom von R wird konstant gehalten und ist unabhängig von Druckschwankungen.
 Der Überschuss wird zum Tank geleitet.
 Kompensator: VCC316G
 Druckbegrenzungsventil: VMG05

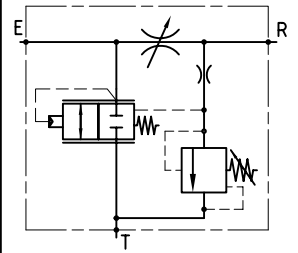

TECHNICAL DATA TECHNISCHE ANGABEN

Max operating pressure Maximaler Betriebsdruck	21MPa 2987psi
Max flow inlet (port E) Eingangs-Volumenstrom (gewinde E)	3/4" BSPP: 150 l/min / 39.6 gpm
Max flow delivery (port R) Ausgangs-Volumenstrom (gewinde R)	3/4" BSPP: 90 l/min / 23.8 gpm
Weight Gewicht	Alloy / Aluminium 2 kg / 4.40 lb ft
Temperature range Betriebstemperatur	-20°/80°C
Filtration Filtergrad	40µ

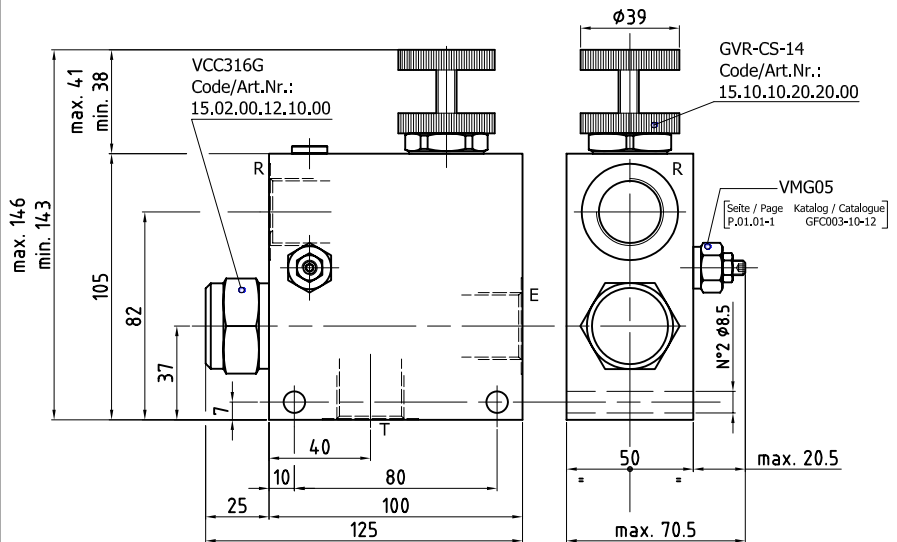
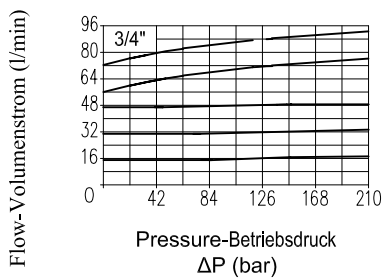

Adjustment options/Einstellung

leakproof socket screw
leckölfreie Regulierungsschraube

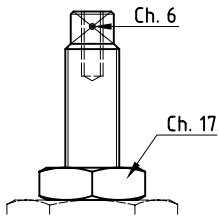

1

handknob and locknut
Handrad und Mutter

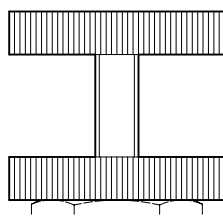

2

ORDERING INSTRUCTIONS - BESTELLANLEITUNG

15 41 22 10 - [] - [] - 0

Adjustment options
Einstellung

- 1** leakproof socket screw
leckölfreie Regulierungsschraube
- 2** handknob and locknut
Handrad und Mutter

Port size
Gewinde

04 G 3/4

Pressure compensated flow regulator valve. It keeps outlet flow from port "C1"- "C2" constant and independent from pressure changes.

Druckkompensiertes Stromregelventil. Der Strom von C1-C2 wird konstant gehalten und ist unabhängig von Druckschwankungen.

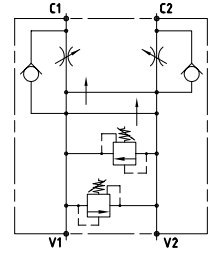

TECHNICAL DATA TECHNISCHE ANGABEN

Max operating pressure Maximaler Betriebsdruck	21MPa / 2987psi: Alloy / Aluminium 35MPa / 5076psi: Steel / Stahl
Max flow inlet (port V1, V2) Eingangs-Volumenstrom (gewinde V1, V2)	150 l/min 39.6 gpm
Max flow delivery (port C1, C2) Ansgangs-Volumenstrom (gewinde C1, C2)	90 l/min 23.8 gpm
Weight Gewicht	2.9 kg (Alloy / Aluminium) 8.0 kg (Steel / Stahl)
Temperature range Betriebstemperatur	-20°/80°C
Filtration Filtergrad	40µ

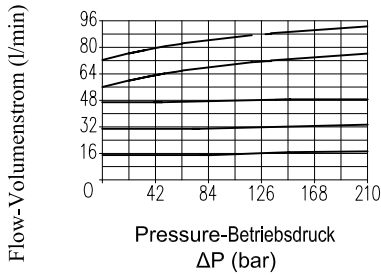

RELIEF VALVE DRUCKBEGRENZUNGSVENTIL

PM010

Adj. range Regelbereich	std setting Standardeinst.	Pressure increase MPa/turn Drucksteigerung MPa je Schraubendrehung
9-25 MPa	20 MPa	2.5

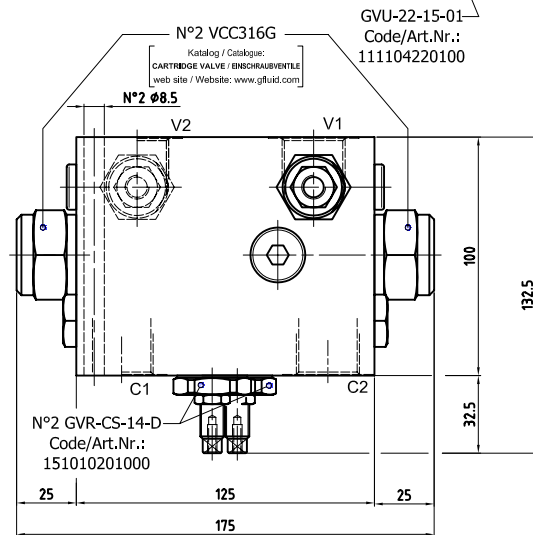
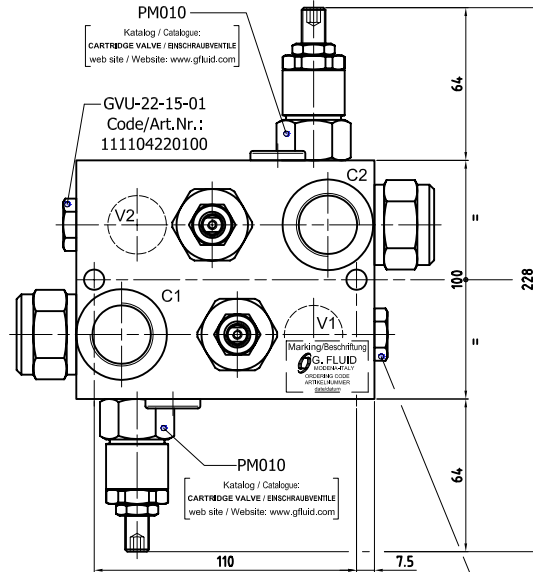

ORDERING CODE - ARTIKELNUMMER

154132001

Port size/Gewinde V1, V2, C1, C2	Material Material	Description Bezeichnung
04 G 3/4	0 Alloy/Aluminium	GRF3-DE-VU-34-A
	1 Zinc. steel/ Verzink. Stahl	GRF3-DE-VU-34-S

This valve divides inlet flow (V) into two equal parts (C1 and C2) or re-combines equal flows in reverse direction.
 It is pressure compensated in order to keep division or re-combination constant.
 Max. admitted slippage $\pm 3\%$.

Dieses Ventil teilt einen Volumenstrom V in 2 gleich große Ströme C1 und C2, unabhängig von der Anwendungslast. Die Rückleitung erfolgt geregelt. Um eine optimale Funktion zu gewährleisten und Druckverluste zu vermeiden, sind die Stromteiler für verschiedene Durchflußbereiche eingestellt.
 Max. erlaubte, Fehler $\pm 3\%$

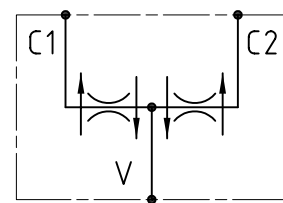
TECHNICAL DATA
TECHNISCHE ANGABEN

Max operating pressure Maximaler Betriebsdruck	25 MPa: Alloy/Aluminium 35 MPa: Zincoated Steel/Verzinkter Stahl
Max. inflow Max. Zulaufölstrom	5.8 - 11 - 22 - 38 l/min
Weight Gewicht	0.9 kg (Aluminium) 2.5 kg (Steel / Stahl)
Temperature range Betriebstemperatur	-20°/80°C
Filtration Filtergrad	10 μ
Division ratio Teilungsverhältnis	50%-50% standard (other upon request) Standard 50%-50% (weitere Optionen auf Anfrage)

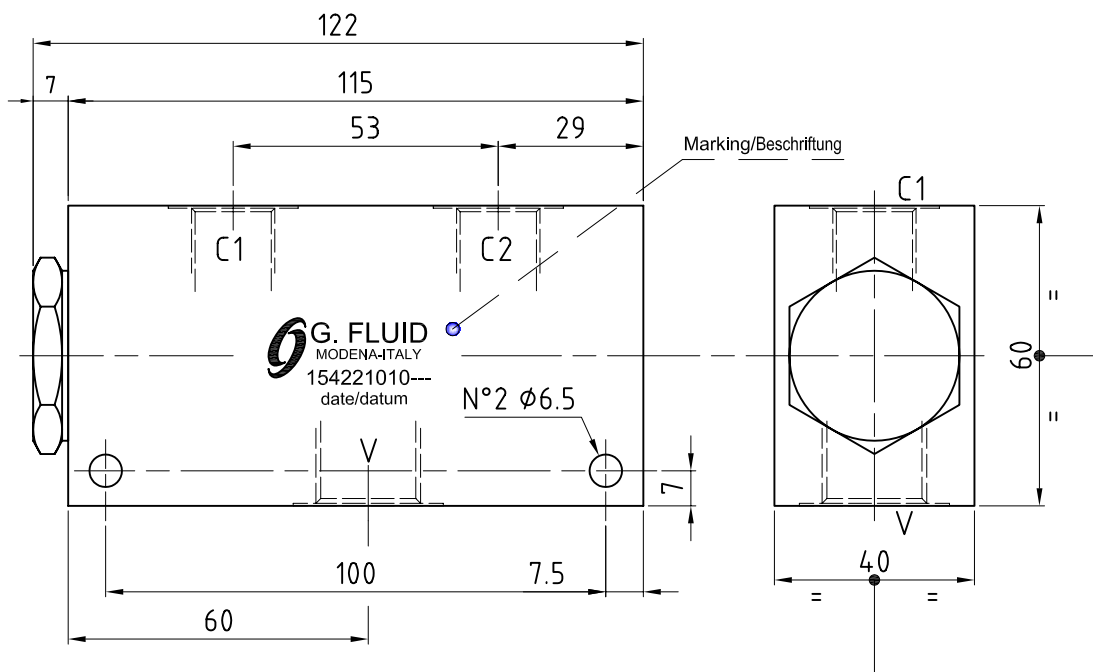
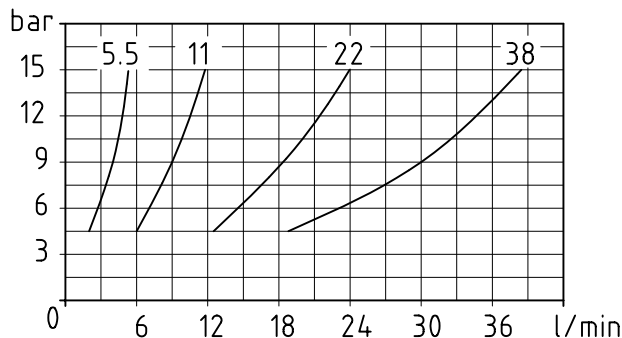
ORDERING INSTRUCTIONS - BESTELLANLEITUNG
15 42 21 01 0X YW

Port size - Gewinde V	C1+C2	X
3/8" BSPP	3/8" BSPP	2
1/2" BSPP	3/8" BSPP	3

Y	inlet flow Durchflußbereich	Description Bezeichnung
1	2.8-5.8 l/min	GDF 38-6 (V: 3/8" BSPP) GDF 12-6 (V: 1/2" BSPP)
2	6.5-11 l/min	GDF 38-11 (V: 3/8" BSPP) GDF 12-11 (V: 1/2" BSPP)
3	13-22 l/min	GDF 38-22 (V: 3/8" BSPP) GDF 12-22 (V: 1/2" BSPP)
4	25-38 l/min	GDF 38-38 (V: 3/8" BSPP) GDF 12-38 (V: 1/2" BSPP)

W	Material Material
0	Alloy/Aluminium
1	Zincoated Steel / Verzinkter Stahl

This valve divides inlet flow (V) into two equal parts (C1 and C2) or re-combines equal flows in reverse direction.
It is pressure compensated in order to keep division or re-combination constant.

Dieses Ventil teilt einen Volumenstrom V in 2 gleich große Ströme C1 und C2, unabhängig von der Anwendungslast. Die Rückleitung erfolgt geregelt. Um eine optimale Funktion zu gewährleisten und Druckverluste zu vermeiden, sind die Stromteiler für verschiedene Durchflusbereiche eingestellt.

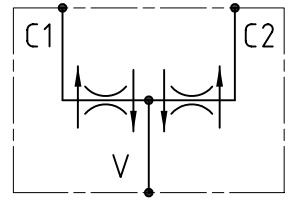
TECHNICAL DATA
TECHNISCHE ANGABEN

Max operating pressure Maximaler Betriebsdruck	25 MPa: Alloy/Aluminium 35 MPa: Zincoated Steel/Verzinkter Stahl
Max. inflow Max. Zulaufölstrom	150 l/min
Weight Gewicht	1.7 kg (Aluminium) 4.8 kg (Steel / Stahl)
Temperature range Betriebstemperatur	-20°/80°C
Filtration Filtergrad	10µ
Division ratio Teilungsverhältnis	50%-50% standard (other upon request) Standard 50%-50% (weitere Optionen auf Anfrage)

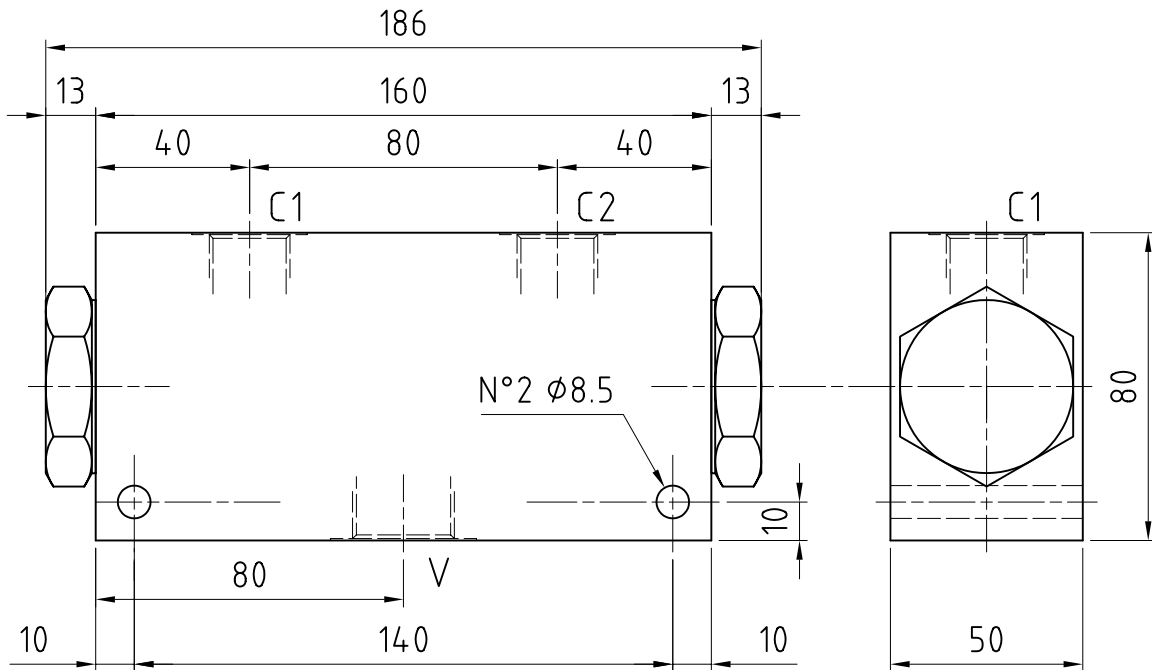
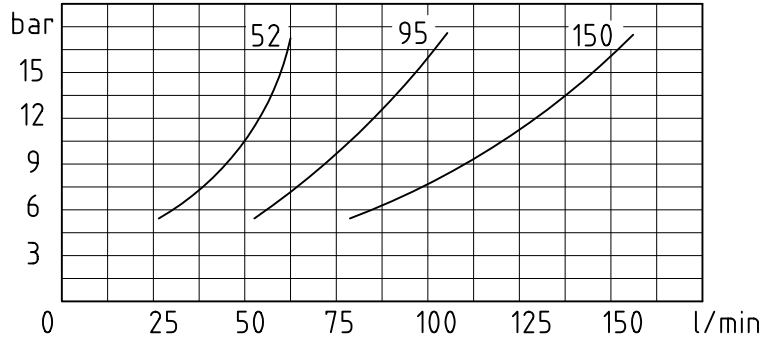
ORDERING INSTRUCTIONS - BESTELLANLEITUNG
15 42 21 01 0X YW

Port size - Gewinde		X
V	C1+C2	
3/4" BSPP	1/2" BSPP	4
1" BSPP	3/4" BSPP	5

Y	inlet flow Durchflusbereich	Description Bezeichnung
1	28-58 l/min	GDF 34-58 (V: 3/4" BSPP) GDF 100-58 (V: 1" BSPP)
2	56-95 l/min	GDF 34-95 (V: 3/4" BSPP) GDF 100-95 (V: 1" BSPP)
3	90-150 l/min	GDF 34-150 (V: 3/4" BSPP) GDF 100-150 (V: 1" BSPP)
4	150-180 l/min	GDF 34-180 (V: 3/4" BSPP) GDF 100-180 (V: 1" BSPP)
5	180-250 l/min	GDF 34-250 (V: 3/4" BSPP) GDF 100-250 (V: 1" BSPP)

W	Material Material
0	Alloy/Aluminium
1	Zincoated Steel / Verzinkter Stahl

This valve divides inlet flow (V) into two equal parts (C1 and C2) or re-combines equal flows in reverse direction.
It is pressure compensated in order to keep division or re-combination constant.

Dieses Ventil teilt einen Volumenstrom V in 2 gleich große Ströme C1 und C2, unabhängig von der Anwendungslast. Die Rückleitung erfolgt geregelt. Um eine optimale Funktion zu gewährleisten und Druckverluste zu vermeiden, sind die Stromteiler für verschiedene Durchflusbereiche eingestellt.

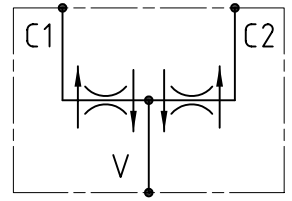
**TECHNICAL DATA
TECHNISCHE ANGABEN**

Max operating pressure Maximaler Betriebsdruck	35 MPa
Max. inflow Max. Zulaufölstrom	4 - 8 - 16 - 32 - 50 l/min
Weight Gewicht	1.2 kg (Steel / Stahl)
Temperature range Betriebstemperatur	-20°/80°C
Filtration Filtergrad	10µ
Division ratio Teilungsverhältnis	50%-50% standard (other upon request) Standard 50%-50% (weitere Optionen auf Anfrage)

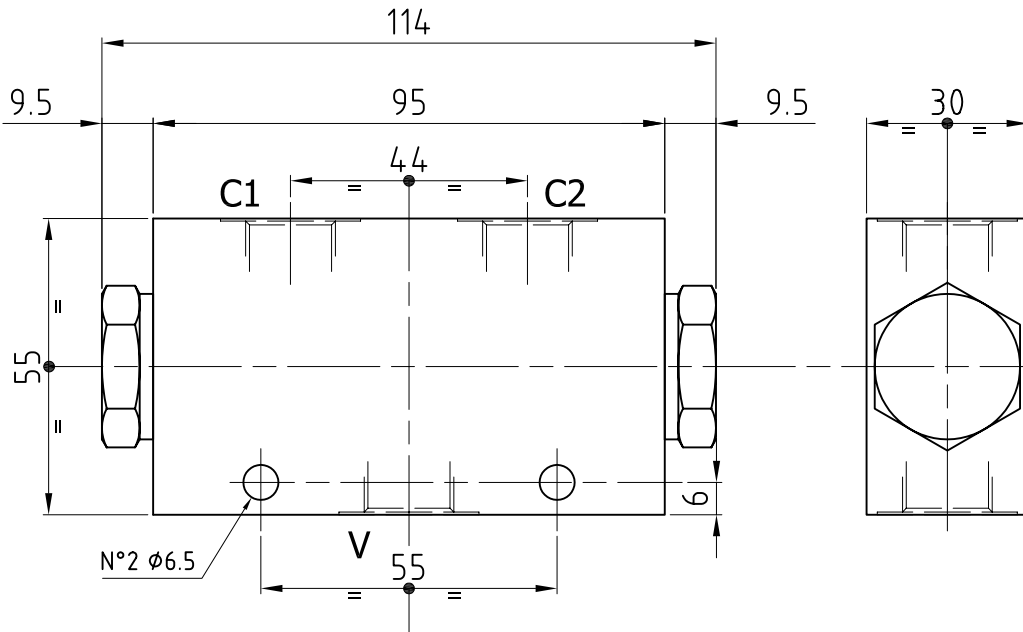
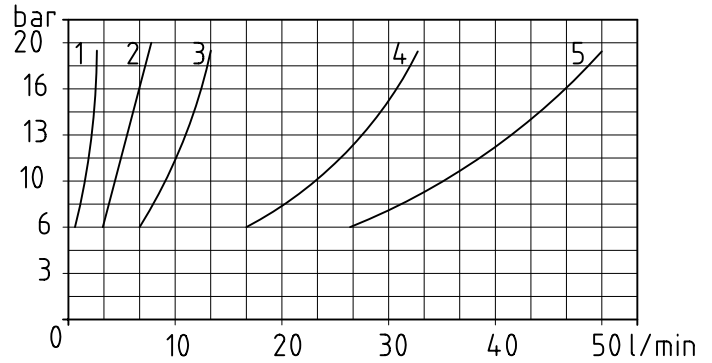

ORDERING INSTRUCTIONS - BESTELLANLEITUNG
15 42 21 03 0X Y1

Thread - Gewinde V	C1+C2	X
3/8" BSPP	3/8" BSPP	2
1/2" BSPP	3/8" BSPP	3

Y	inlet flow Durchflusbereich	Description Bezeichnung
1	2+4 l/min	GDF16 38-4 (V: 3/8" BSPP) GDF16 12-4 (V: 1/2" BSPP)
2	4+8 l/min	GDF16 38-8 (V: 3/8" BSPP) GDF16 12-8 (V: 1/2" BSPP)
3	8+16 l/min	GDF16 38-16 (V: 3/8" BSPP) GDF16 12-16 (V: 1/2" BSPP)
4	16+32 l/min	GDF16 38-32 (V: 3/8" BSPP) GDF16 12-32 (V: 1/2" BSPP)
5	25+50 l/min	GDF16 38-50 (V: 3/8" BSPP) GDF16 12-50 (V: 1/2" BSPP)

This valve divides inlet flow (V) into two equal parts (C1 and C2) or re-combines equal flows in reverse direction.
It is pressure compensated in order to keep division or re-combination constant.

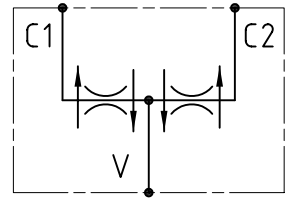
Dieses Ventil teilt einen Volumenstrom V in 2 gleich große Ströme C1 und C2, unabhängig von der Anwendungslast. Die Rückleitung erfolgt geregelt. Um eine optimale Funktion zu gewährleisten und Druckverluste zu vermeiden, sind die Stromteiler für verschiedene Durchflusbereiche eingestellt.

**TECHNICAL DATA
TECHNISCHE ANGABEN**

Max operating pressure Maximaler Betriebsdruck	35 MPa
Max. inflow Max. Zulaufölstrom	4 - 8 - 16 - 32 - 50 l/min
Weight Gewicht	1.2 kg (Steel / Stahl)
Temperature range Betriebstemperatur	-20°/80°C
Filtration Filtergrad	10µ
Division ratio Teilungsverhältnis	50%-50% standard (other upon request) Standard 50%-50% (weitere Optionen auf Anfrage)

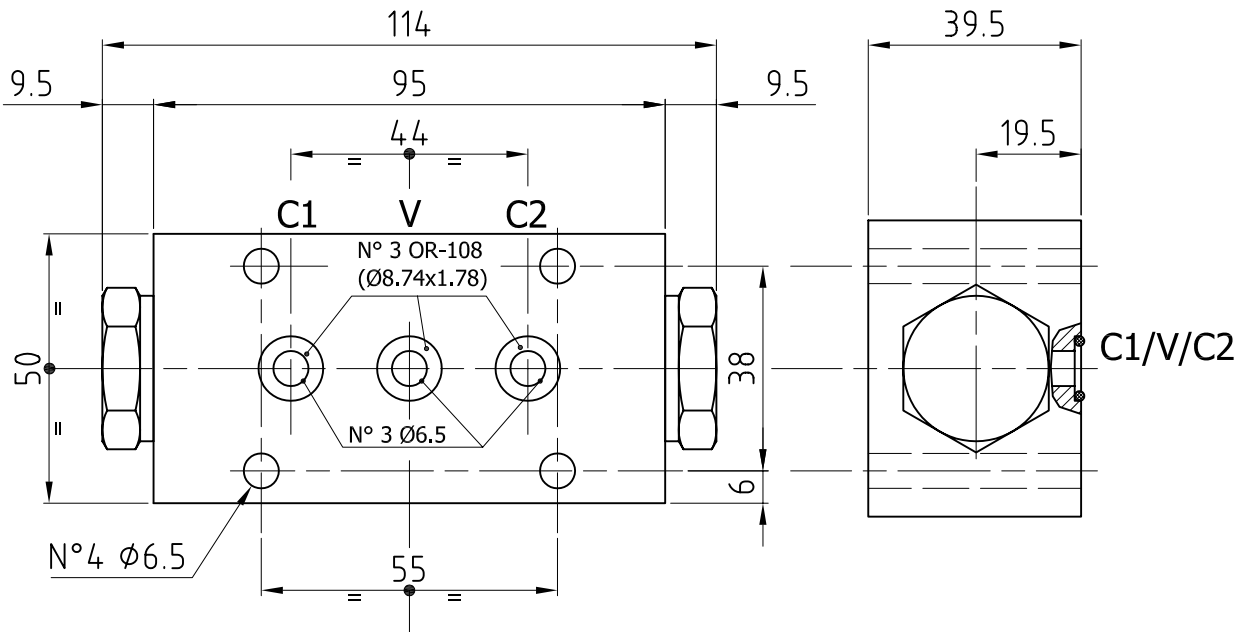
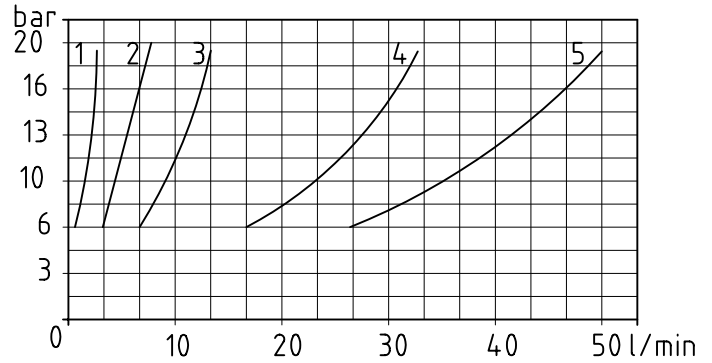
ORDERING INSTRUCTIONS - BESTELLANLEITUNG
15 42 21 03 0F Y1

Y	inlet flow Durchflusbereich
1	2÷4 l/min
2	4÷8 l/min
3	8÷16 l/min
4	16÷32 l/min
5	25÷50 l/min

TECHNICAL DATA TECHNISCHE ANGABEN

Max operating pressure Maximaler Betriebsdruck	35 MPa 5076 psi
Priority flow range / Hauptdurchfluß Inlet flow range / Eingangsfuß	1.5-85 l/min → 0.4-22.4 gpm up to 100 l/min-bis zu 100 l/min
Weight Gewicht	3.4 kg
Material Material	Zincoated steel Verzinkter Stahl

- The priority flow is delivered once the solenoid valve (2) is energized; it can be adjusted by the restrictor (3); turn anti clock-wise for flow increase (approx. 18 l/min per turn).
- Drain for "T" with not energized solenoid valve: up to 1.5 l/min
- Back pressure in "T": 1.5 bar max.
- For the correct operation of the compensating spool, the priority port "A" must always be pressurized (8-9 bar minimum) also when the priority outlet is not being used

- Hauptdurchfluß, wenn das Magnetventil (2) angeregt ist. Kann durch das Drosselventil (3) reguliert werden: Durch Drehen gegen den Uhrzeigersinn wird die Durchflußrate erhöht (ca. 18 l/min pro Umdrehung).
- Abfluß in T bei nicht-angeregtem Magnetventil: bis zu 1,5 l/min
- Rückdruck in T: max. 1,5 bar
- Für die korrekte Funktion der Kompensationsspule muß an dem Hauptanschluß Druck (mindestens 8 - 9 bar) anliegen. Dies gilt auch, wenn der Hauptabfluß nicht verwendet wird.

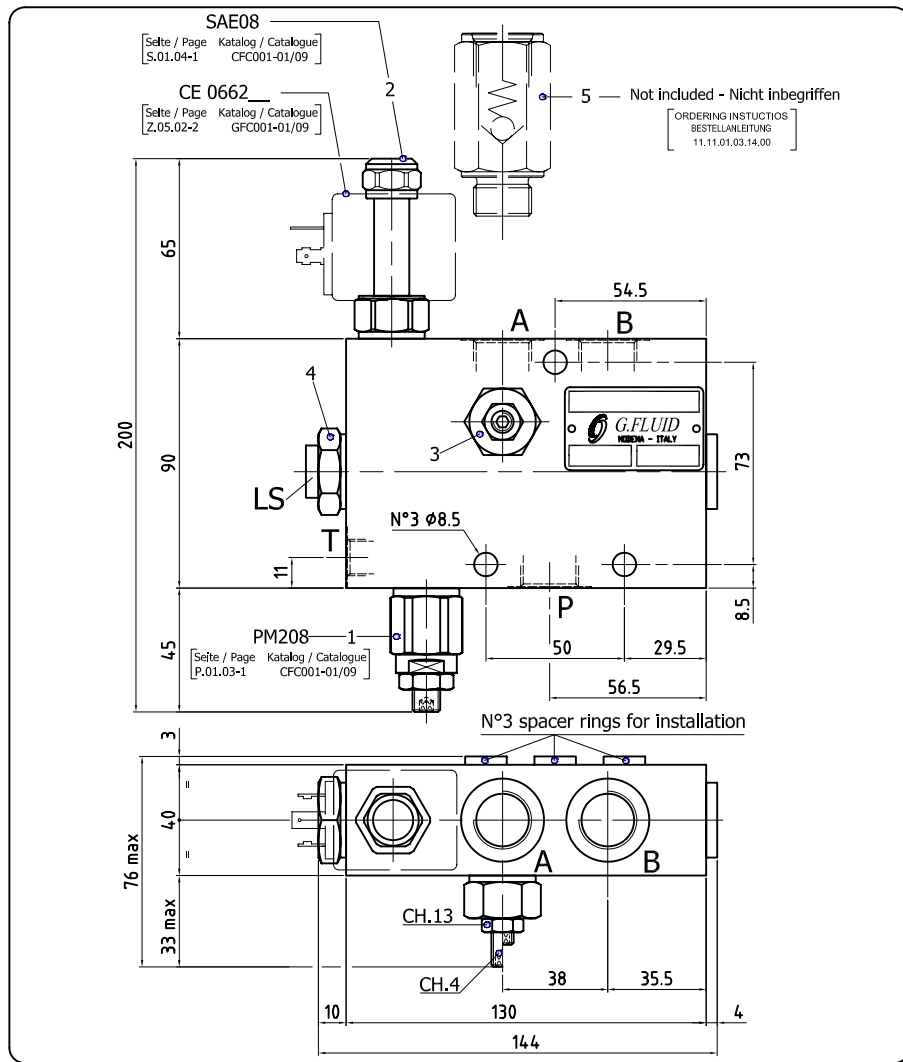
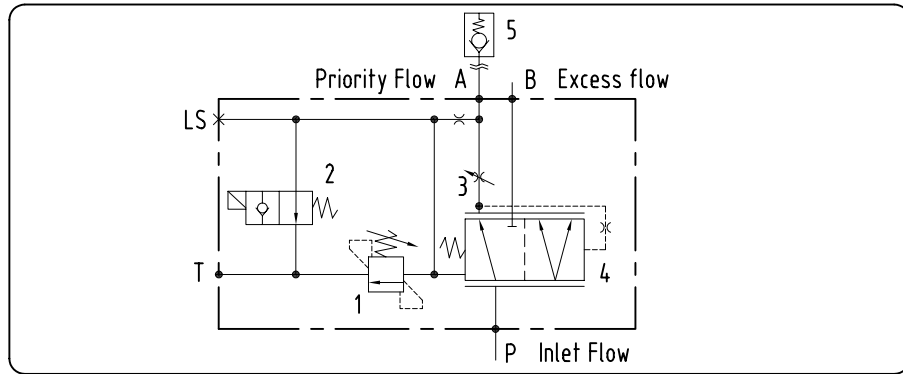
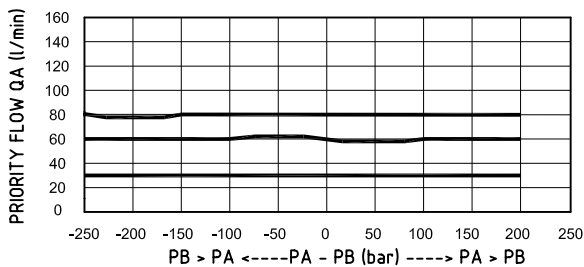
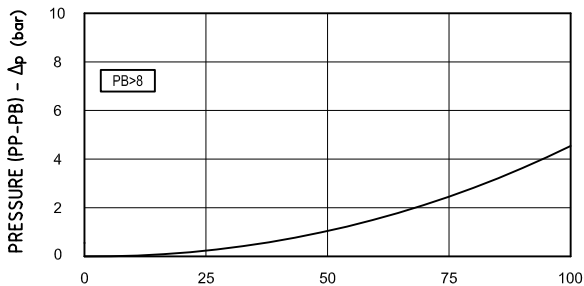

ORDERING INSTRUCTIONS - BESTELLANLEITUNG

154122160 X Y

Port size - Gewinde		X
P, A, B	T	
G 1/2"	G 1/4"	03
3/4 -16 UNF-2B	9/16-18 UNF-2B	44

Y	Spring pressure range Feder-Einstellbereich	Pressure increase MPa/turn Drucksteigerung MPa je Schraubendrehung	Standard setting MPa Standardeinstellung MPa
	1	6-21 MPa	2.4
2	10-35 MPa	5.4	35

TECHNICAL DATA TECHNISCHE ANGABEN

Max operating pressure Maximaler Betriebsdruck	35 MPa 5076 psi
Priority flow range / Hauptdurchfluß Inlet flow range / Eingangfluß	1.5-140 l/min → 0.4-37 gpm up to 200 l/min-bis zu 200 l/min
Weight Gewicht	4.8 kg
Material Material	Zincoated steel Verzinkter Stahl

- The priority flow is delivered once the solenoid valve (2) is energized; it can be adjusted by the restrictor (3); turn anti clock-wise for flow increase (approx. 20 l/min per turn).
- Drain for "T" with not energized solenoid valve: up to 1.5 l/min
- Back pressure in "T": 1.5 bar max.
- For the correct operation of the compensating spool, the priority port "A" must always be pressurized (8-9 bar minimum) also when the priority outlet is not being used

- Hauptdurchfluß, wenn das Magnetventil (2) angeregt ist. Kann durch das Drosselventil (3) reguliert werden: Durch Drehen gegen den Uhrzeigersinn wird die Durchflußrate erhöht (ca. 20 l/min pro Umdrehung).
- Abfluß in T bei nicht-angeregtem Magnetventil: bis zu 1,5 l/min
- Rückdruck in T: max. 1,5 bar
- Für die korrekte Funktion der Kompensationsspule muß an dem Hauptanschluß Druck (mindestens 8 - 9 bar) anliegen. Dies gilt auch, wenn der Hauptabfluß nicht verwendet wird.

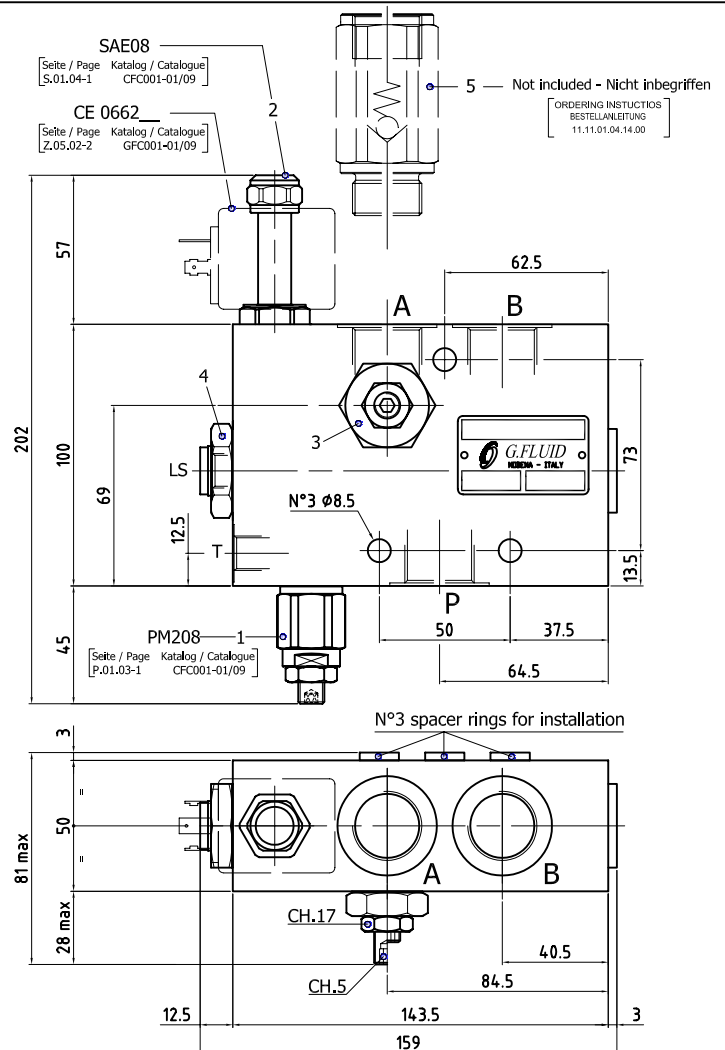
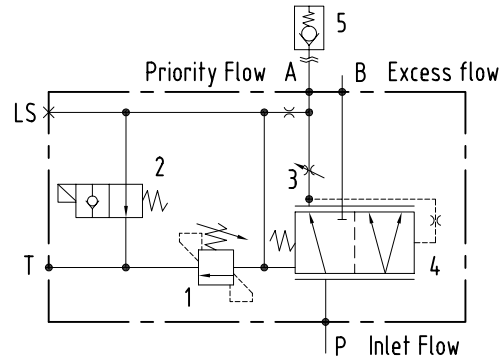
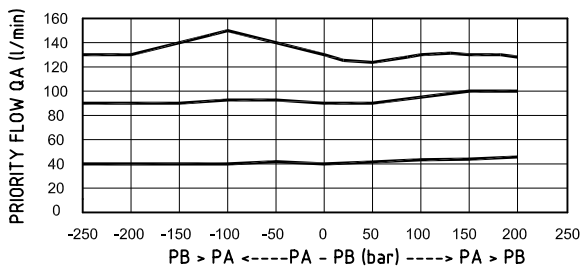
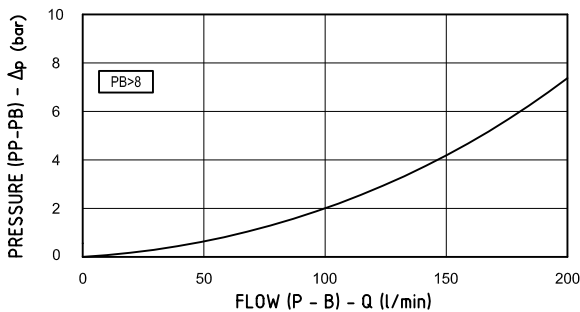

ORDERING INSTRUCTIONS - BESTELLEANLEITUNG

154122060 X Y

Port size - Gewinde		X
P, A, B	T, LS	
G 3/4"	G 1/4"	04
1 1/16 -12 UN-2B	9/16-18 UNF-2B	46

Y	Spring pressure range Feder-Einstellbereich	Pressure increase MPa/turn Drucksteigerung MPa je Schraubendrehung	Standard setting MPa Standardeinstellung MPa
	1	6-21 MPa	2.4
2	10-35 MPa	5.4	35

GRF-SA-PM-100

TECHNICAL DATA TECHNISCHE ANGABEN

Max operating pressure Maximaler Betriebsdruck	35 MPa 5076 psi
Priority flow range / Hauptdurchfluß Inlet flow range / Eingangsfuß	1.5-220 l/min → 0.4-58 gpm up to 300 l/min-bis zu 300 l/min
Weight Gewicht	9.5 kg
Material Material	Zincoated steel Verzinkter Stahl

- The priority flow is delivered once the solenoid valve (2) is energized; it can be adjusted by the restrictor (3): turn anti clock-wise for flow increase (approx. 26 l/min per turn).
- Drain for "T" with not energized solenoid valve: up to 1.5 l/min
- Back pressure in "T": 1.5 bar max.
- For the correct operation of the compensating spool, the priority port "A" must always be pressurized (8-9 bar minimum) also when the priority outlet is not being used
- Hauptdurchfluß, wenn das Magnetventil (2) angeregt ist. Kann durch das Drosselventil (3) reguliert werden: Durch Drehen gegen den Uhrzeigersinn wird die Durchflußrate erhöht (ca. 26 l/min pro Umdrehung).
- Abfluß in T bei nicht-angeregtem Magnetventil: bis zu 1,5 l/min
- Rückdruck in T: max. 1,5 bar
- Für die korrekte Funktion der Kompensationsspule muß an dem Hauptanschluß Druck (mindestens 8 - 9 bar) anliegen. Dies gilt auch, wenn der Hauptabfluß nicht verwendet wird.

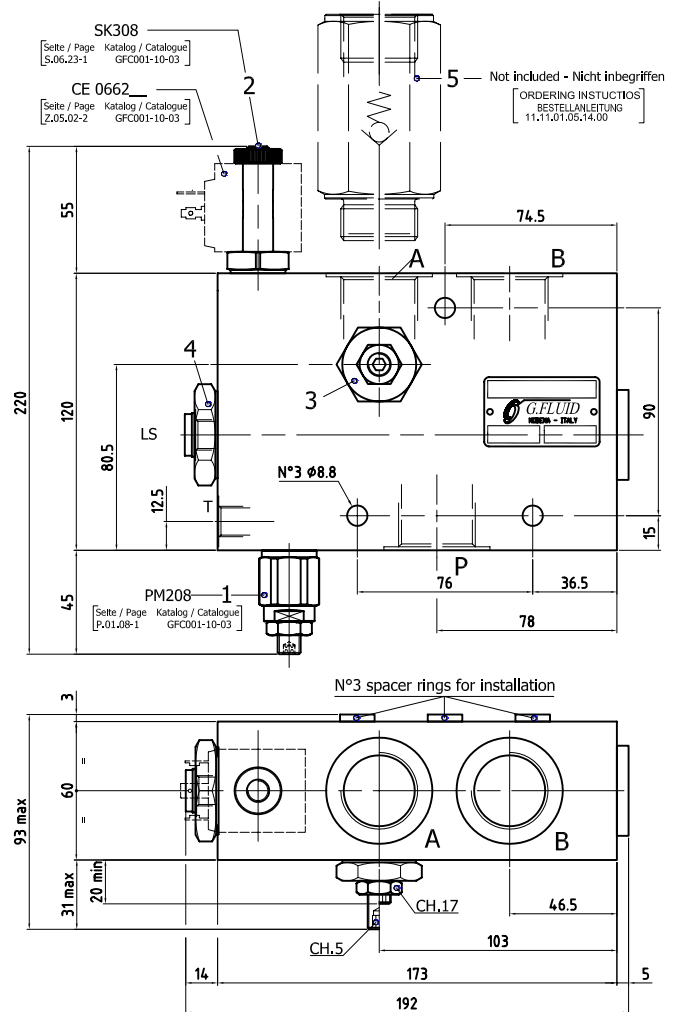
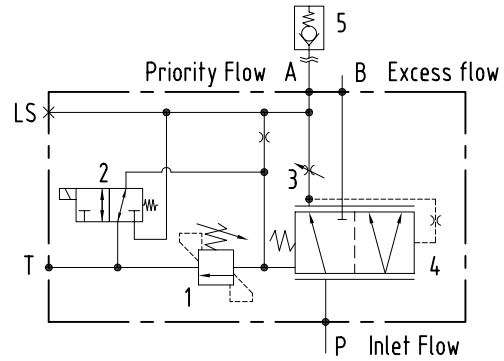
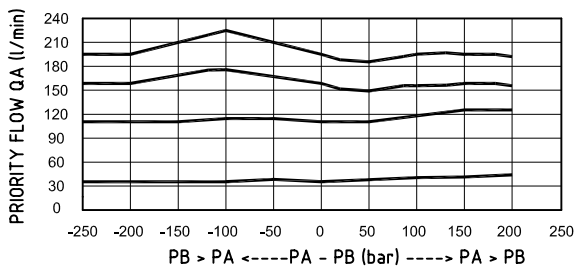
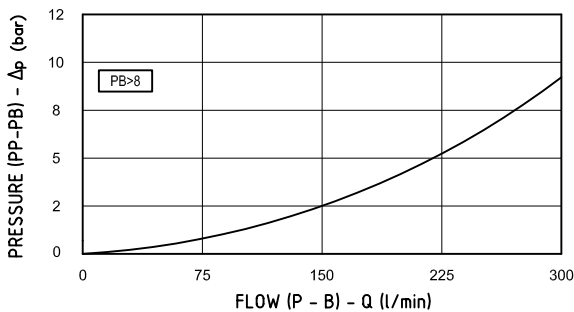

ORDERING INSTRUCTIONS - BESTELLANLEITUNG

154122060 X Y

Port size - Gewinde		X
P, A, B	T, LS	
G 1"	G 1/4"	05
1 5/16 -12 UN-2B	9/16-18 UNF-2B	48

Y	Spring pressure range Feder-Einstellbereich	Pressure increase MPa/turn Drucksteigerung MPa je Schraubendrehung	Standard setting MPa Standardeinstellung MPa
	1	6-21 MPa	2.4
2	10-35 MPa	5.4	35

GRF-SA-PM-114

TECHNICAL DATA TECHNISCHE ANGABEN

Max operating pressure Maximaler Betriebsdruck	35 MPa 5076 psi
Priority flow range / Hauptdurchfluß Inlet flow range / Eingangsfuß	1.5-300 l/min → 0.4-79.2 gpm up to 400 l/min-bis zu 400 l/min
Weight Gewicht	12.5 kg
Material Material	Zincoated steel Verzinkter Stahl

- The priority flow is delivered once the solenoid valve (2) is energized; it can be adjusted by the restrictor (3): turn anti clock-wise for flow increase (approx. 28 l/min per turn).
- Drain for "T" with not energized solenoid valve: up to 1.5 l/min
- Back pressure in "T": 1.5 bar max.
- For the correct operation of the compensating spool, the priority port "A" must always be pressurized (8-9 bar minimum) also when the priority outlet is not being used
- Hauptdurchfluß, wenn das Magnetventil (2) angeregt ist. Kann durch das Drosselventil (3) reguliert werden: Durch Drehen gegen den Uhrzeigersinn wird die Durchflußrate erhöht (ca. 28 l/min pro Umdrehung).
- Abfluß in T bei nicht-angeregtem Magnetventil: bis zu 1,5 l/min
- Rückdruck in T: max. 1,5 bar
- Für die korrekte Funktion der Kompensationsspule muß an dem Hauptanschluß Druck (mindestens 8 - 9 bar) anliegen. Dies gilt auch, wenn der Hauptabfluß nicht verwendet wird.

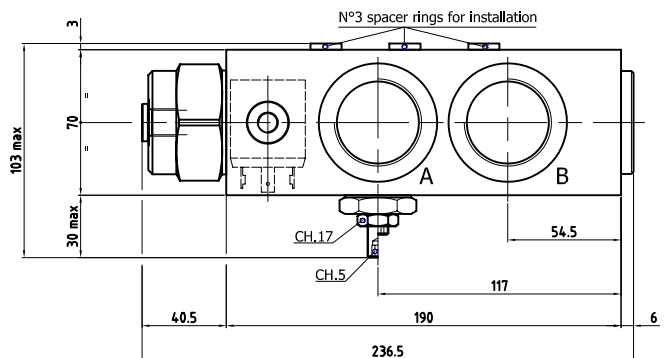
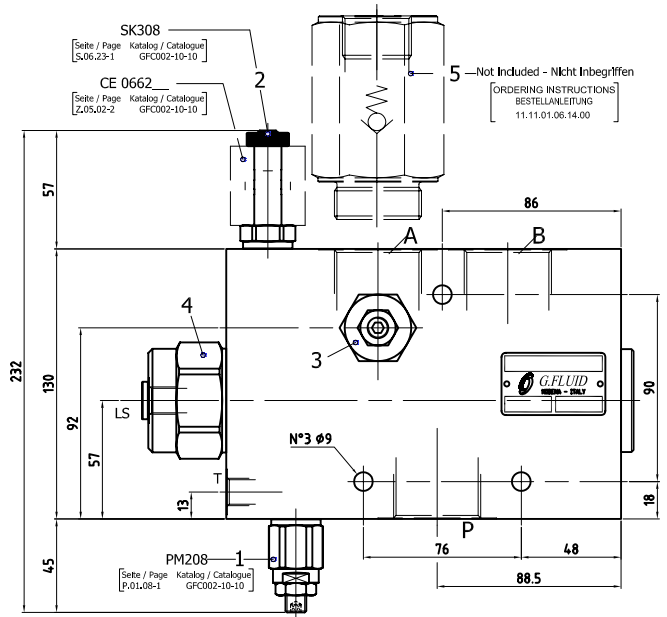
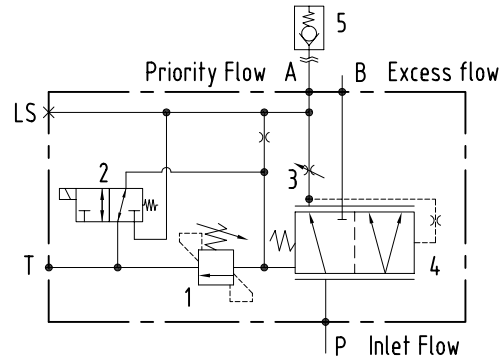
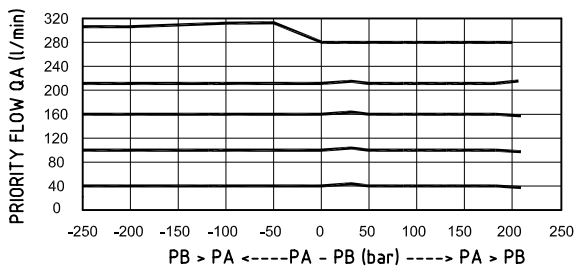
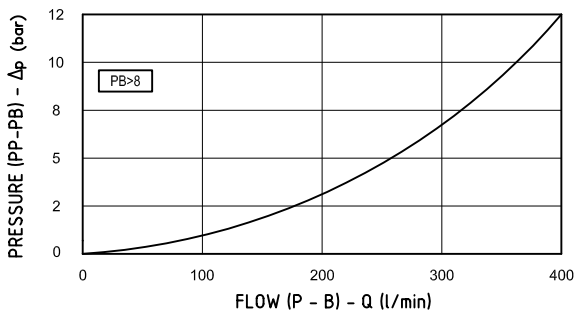

ORDERING INSTRUCTIONS - BESTELLANLEITUNG

154122060 X Y

Port size - Gewinde		X
P, A, B	T, LS	
G 1 1/4"	G 1/4"	06
1 5/8 -12 UN-2B	9/16-18 UNF-2B	49

Y	Spring pressure range Feder-Einstellbereich	Pressure increase MPa/turn Drucksteigerung MPa je Schraubendrehung	Standard setting MPa Standardeinstellung MPa
	1	6-21 MPa	2.4
2	10-35 MPa	5.4	35

**TECHNICAL DATA
 TECHNISCHE ANGABEN**

Max operating pressure Maximaler Betriebsdruck	35 MPa 5076 psi
Temperature range Betriebstemperatur	-20°/80°C

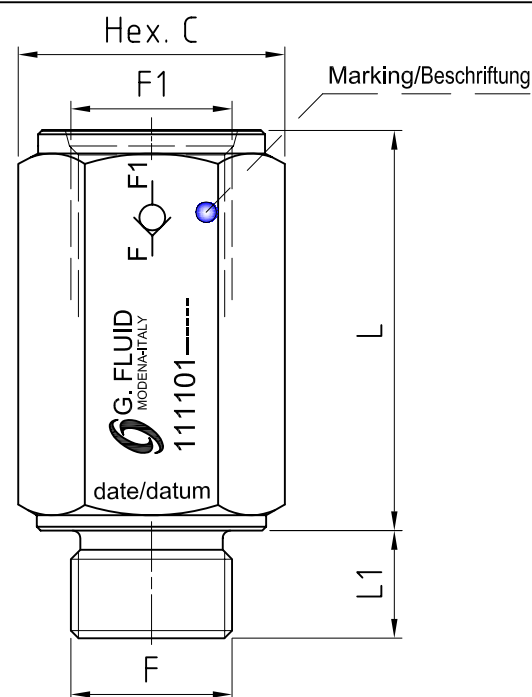
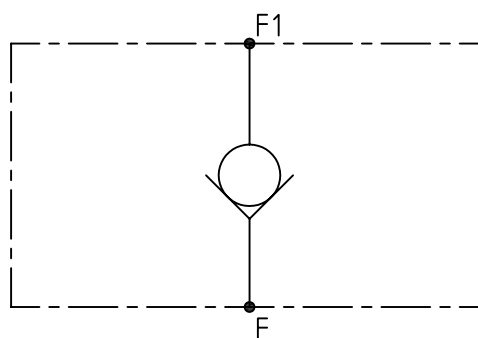

PORT SIZE GEWINDE F - F1	CRACKING PRESSURE ÖFFNUNGSDRUCK bar	L	L1	C	DESCRIPTION BEZEICHNUNG	ORDERING INSTRUCTIONS BESTELLANLEITUNG
G 1/2	8	52	14	30	GVU-MF-12G	11.11.01.03.14.00
* 3/4-16 UNF	8	52	14	30	GVU-MF-34UNF	11.11.01.0A.14.00
G 3/4	8	61	16	36	GVU-MF-34G	11.11.01.04.14.00
* 1-1/16-12 UN	8	61	16	36	GVU-MF-1-116	11.11.01.0B.14.00
G1	8	87	18	46	GVU-MF-1G	11.11.01.05.14.00
* 1-5/16-12 UN	8	82	18	46	GVU-MF-1-516	11.11.01.0C.14.00
G 1-1/4	8	145	20	55	GVU-MF-1-14G	11.11.01.06.14.00
* 1-5/8-12 UN	8	102	18	55	GVU-MF-1-58	11.11.01.0D.14.00

* SPECIAL COIL UPON REQUEST/SONDERSPULE AUF ANFRAGE

**TECHNICAL DATA
TECHNISCHE ANGABEN**

Temperature range Betriebstemperatur	-20°/80°C
Filtration Filtergrad	40µ
Material Material	Zincoated Steel Verzinkter Stahl

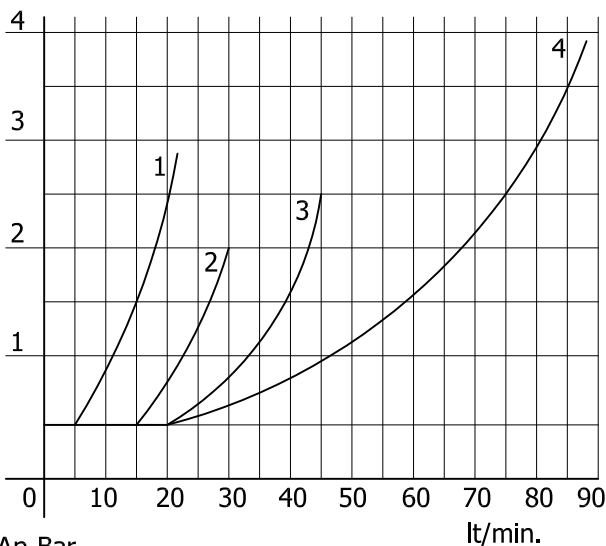
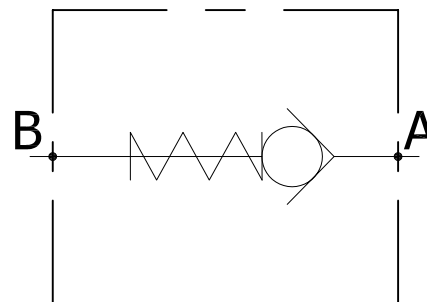
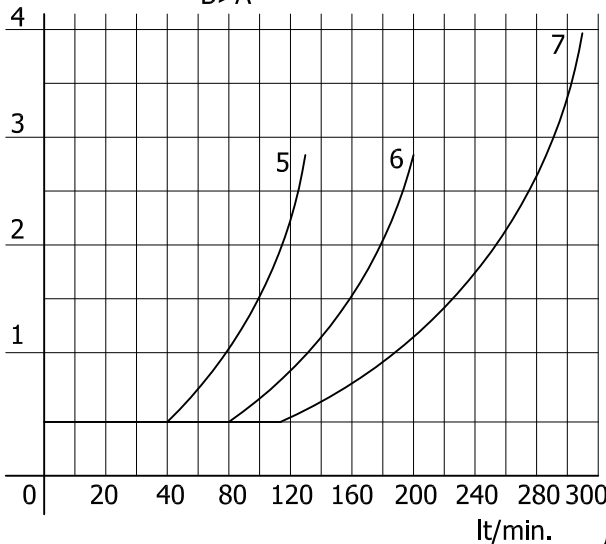
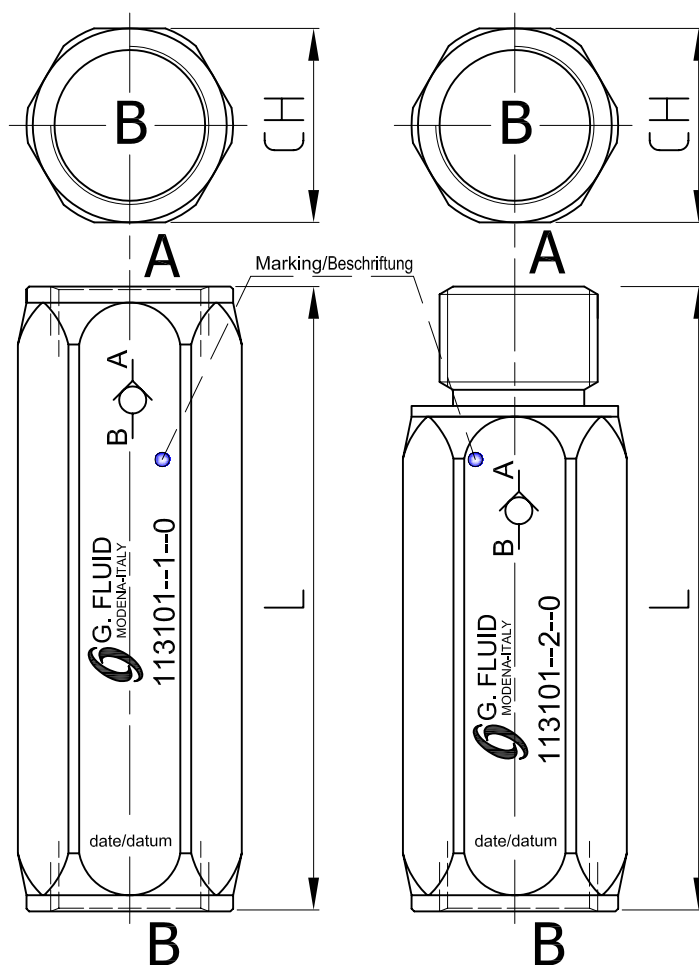
Δp-Bar

Δp-Bar
B>A

Female-Female
Male-Female

**ORDERING INSTRUCTIONS
BESTELLANLEITUNG**
113101 _ _ _ _ 0

Port size Gewinde	
G 1/4"	01
G 3/8"	02
G 1/2"	03
G 3/4"	04
G 1"	05
G 1 1/4"	06
G 1 1/2"	07

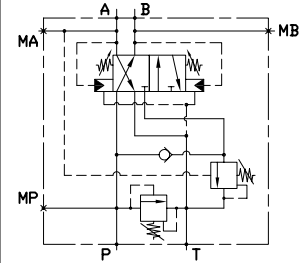
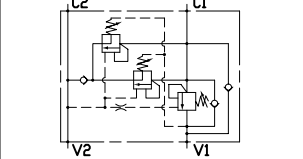
Version Ausführung	
Female-Female	1
Male-Female	2

Cracking pressure Öffnungsdruck (bar)	
00	0.5
01	2.5
02	5
03	10

Port size - Gewinde A-B	Max operating pressure Maximaler Betriebsdruck (bar)	Max flow Volumenstrom (lt/min)	CH	Weight Gewicht (kg)	L (mm)		Chart Nr. Abbildung Nr.
					Female-Female	Male-Female	
G 1/4"	350	12	ES. 19	0.10	62	58	1
G 3/8"	350	30	ES. 24	0.17	68	64	2
G 1/2"	320	45	ES. 30	0.22	78	72	3
G 3/4"	300	85	ES. 36	0.45	88	84	4
G 1"	250	140	ES. 45	0.97	112	105	5
G 1 1/4"	250	200	ES. 55	1.68	145	125	6
G 1 1/2"	210	310	ES. 65	2.10	155	138	7

Scheme Schema	Description Bezeichnung	max flow max Durchfluß	max pressure max Arbeitsdruck	page Seite
	<p>GVS-RIG-AUT-100-031-02</p> <p>GVS-RIG-AUT-200-032-01</p>	<p>100 l/min 26.4 gpm</p> <p>200 l/min 52.8 gpm</p>	<p>35 MPa 5076 psi</p>	<p>4.001.20</p> <p>4.001.24</p>
	<p>GVS-RIG-3PB042-048-RUD</p>	<p>400 l/min 105.6 gpm</p>	<p>35 MPa 5076 psi</p>	<p>4.001.30</p>

**TECHNICAL DATA
 TECHNISCHE ANGABEN**

Max operating pressure Maximaler Betriebsdruck	35 MPa 5076 psi
Max flow Volumenstrom	100 l/min 26.4 gpm
Temperature range Betriebstemperatur	-20°/80°C
Filtration Filtergrad	40µ
Weight Gewicht	11.2 kg
Material Material	Zincoated Steel Verzinkter Stahl

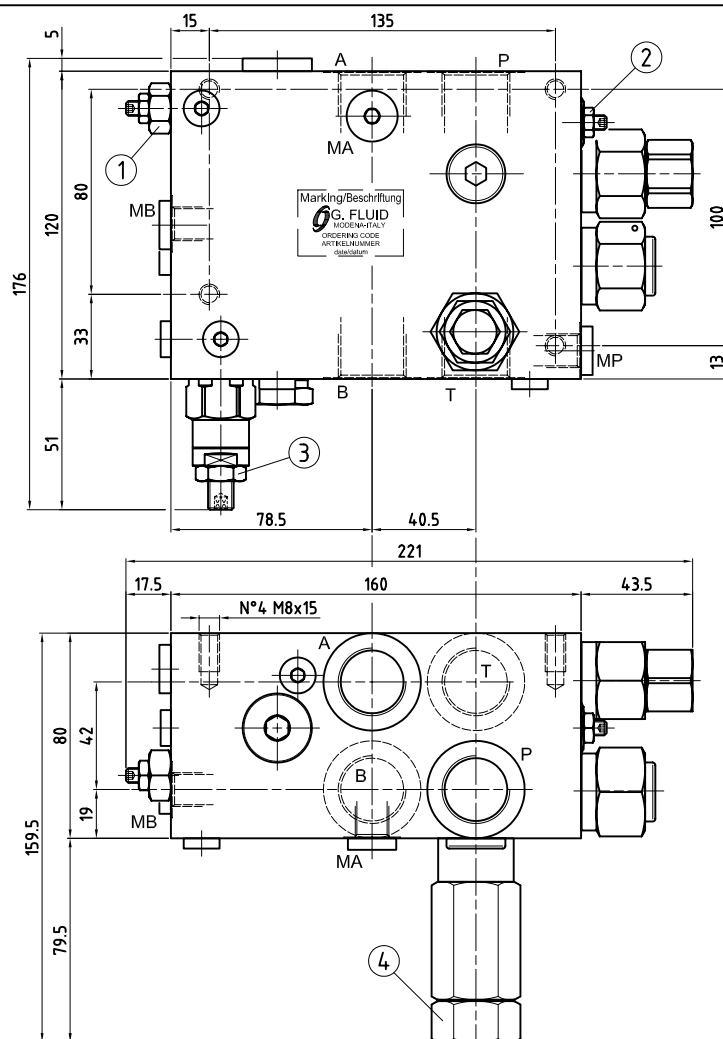
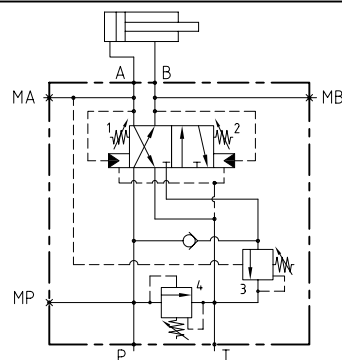

VALVE VENTIL	SETTING EINSTELLUNG	RANGE EINSTELLBEREICH
cylinder out 1	200 bar	± 200÷460 bar
cylinder in 2	80 bar	± 25÷250 bar
differential 3	160 bar	± 100÷350 bar
4	220 bar	± 130÷350 bar

**PORT SIZE
 GEWINDE**

P, T, A, B	G 3/4"
MA, MB, MP	G 1/4"

ORDERING CODE - ARTIKELNUMMER
031.07.12.02

**TECHNICAL DATA
 TECHNISCHE ANGABEN**

Max operating pressure Maximaler Betriebsdruck	35 MPa 5076 psi
Max flow Volumenstrom	200 l/min 52.8 gpm
Temperature range Betriebstemperatur	-20°/80°C
Filtration Filtergrad	40μ
Weight Gewicht	20.6 kg
Material Material	Zincoated Steel Verzinkter Stahl

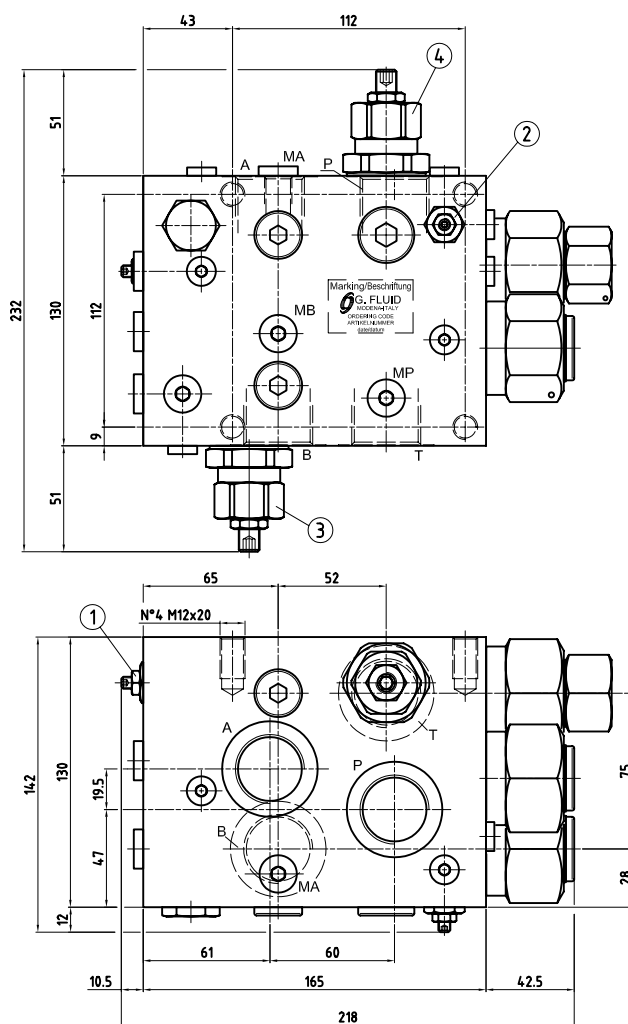
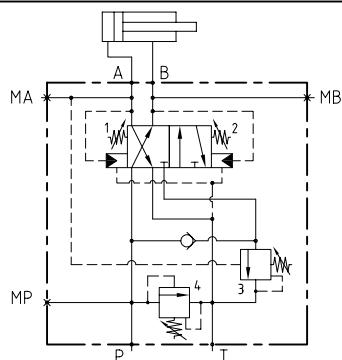

VALVE VENTIL	SETTING EINSTELLUNG	RANGE EINSTELLBEREICH
cylinder out 1	275 bar	± 200÷460 bar
cylinder in 2	100 bar	± 25÷250 bar
differential 3	200 bar	± 100÷350 bar
4	300 bar	± 100÷350 bar

**PORT SIZE
 GEWINDE**

P, T, A, B	G 1"
MA, MB, MP	G 1/4"

ORDERING CODE - ARTIKELNUMMER
032.07.12.01

**TECHNICAL DATA
 TECHNISCHE ANGABEN**

Max operating pressure Maximaler Betriebsdruck	42 MPa 5973 psi
Max flow Volumenstrom	400 l/min 105.6 gpm
Temperature range Betriebstemperatur	-20°/80°C
Filtration Filtergrad	40µ
Weight/Material Gewicht/Material	18.7 kg Zinc. Steel/Verzink. Stahl
Pilot ratio Steuerverhältnis	4:1

Diagram/Diagramm

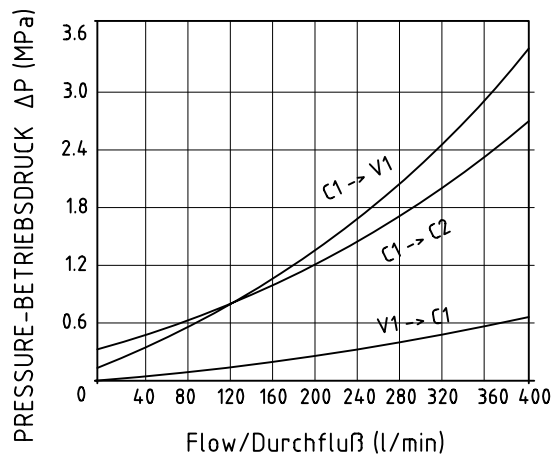
**PORT SIZE
 GEWINDE**

V1, V2	1-1/4 SAE 6000
C1, C2	Ø28

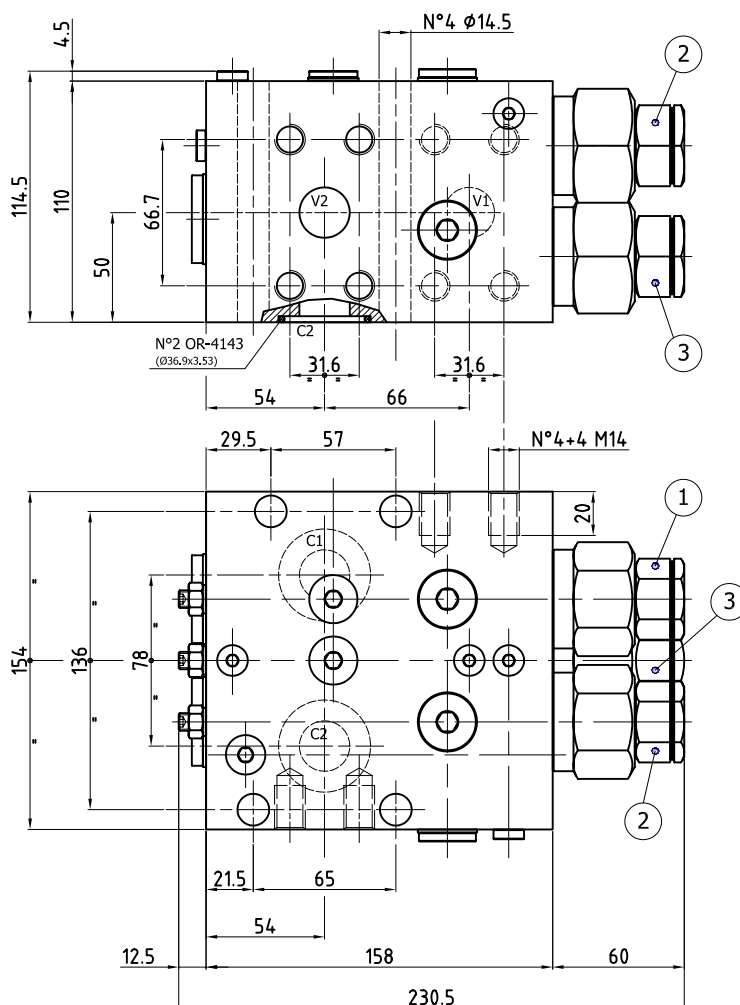
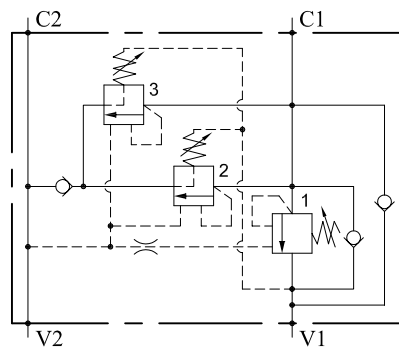
ORDERING INSTRUCTIONS - BESTELLANLEITUNG
048.09.06.00

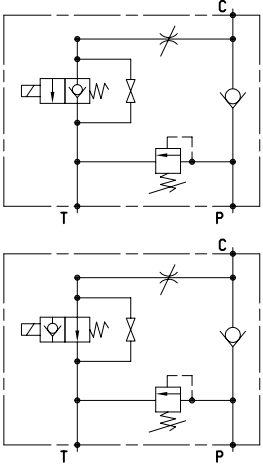
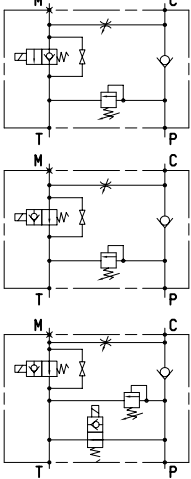
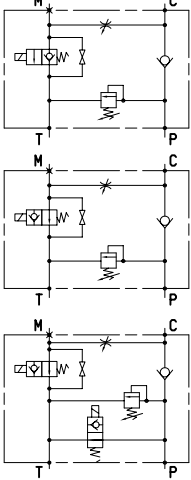
Scheme Schema	Description Bezeichnung	max flow max Durchfluß	max pressure max Arbeitsdruck	page Seite
	<p style="text-align: center;">GV-CE-SE-10-ST-1</p> <p style="text-align: center;">GV-CE-SE-10-ST-2</p>	<p style="text-align: center;">30 l/min 7.9 gpm</p>	<p style="text-align: center;">25 MPa 3626 psi</p>	<p style="text-align: center;">5.001.01</p>
	<p style="text-align: center;">GVS-VMG31-SCE08-VU</p> <p style="text-align: center;">GVS-VMG31-SAE08-VU</p> <p style="text-align: center;">GVS-VMG31-SCE08-BYP-VU</p>	<p style="text-align: center;">30 l/min 7.9 gpm</p>	<p style="text-align: center;">25 MPa 3626 psi</p>	<p style="text-align: center;">5.001.02</p>
	<p style="text-align: center;">GVS-GVSP150-SCE34-VU</p> <p style="text-align: center;">GVS-GVSP150-SAE34-VU</p> <p style="text-align: center;">GVS-GVSP150-SCE34-BYP-VU</p>	<p style="text-align: center;">80 l/min 21.1 gpm</p>	<p style="text-align: center;">25 MPa 3626 psi</p>	<p style="text-align: center;">5.001.03</p>

GV-CE-SE-10-ST-___

TECHNICAL DATA TECHNISCHE ANGABEN

Max operating pressure Maximaler Betriebsdruck	25 MPa 3555 psi
Max flow Volumenstrom	30 l/min 7.9 gpm
Temperature range Betriebstemperatur	-20°/80°C
Filtration Filtergrad	40µ
Weight Gewicht	0.75 kg
Material	Alloy Aluminium

Diagram/Diagramm

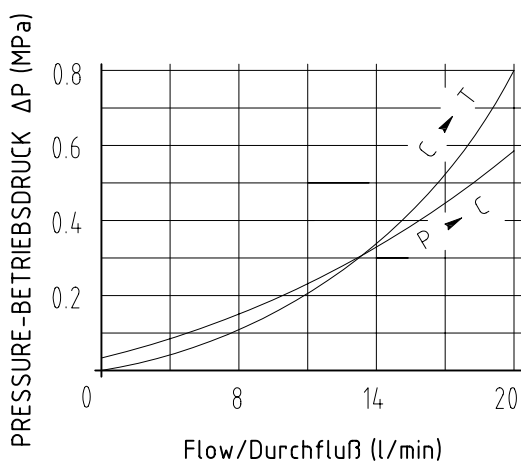

GV-CE-SE-10-ST-1....

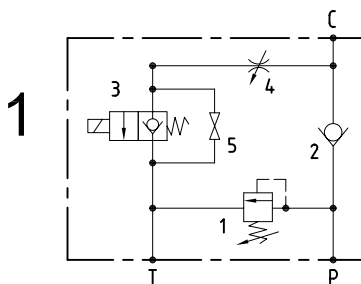

GV-CE-SE-10-ST-2....

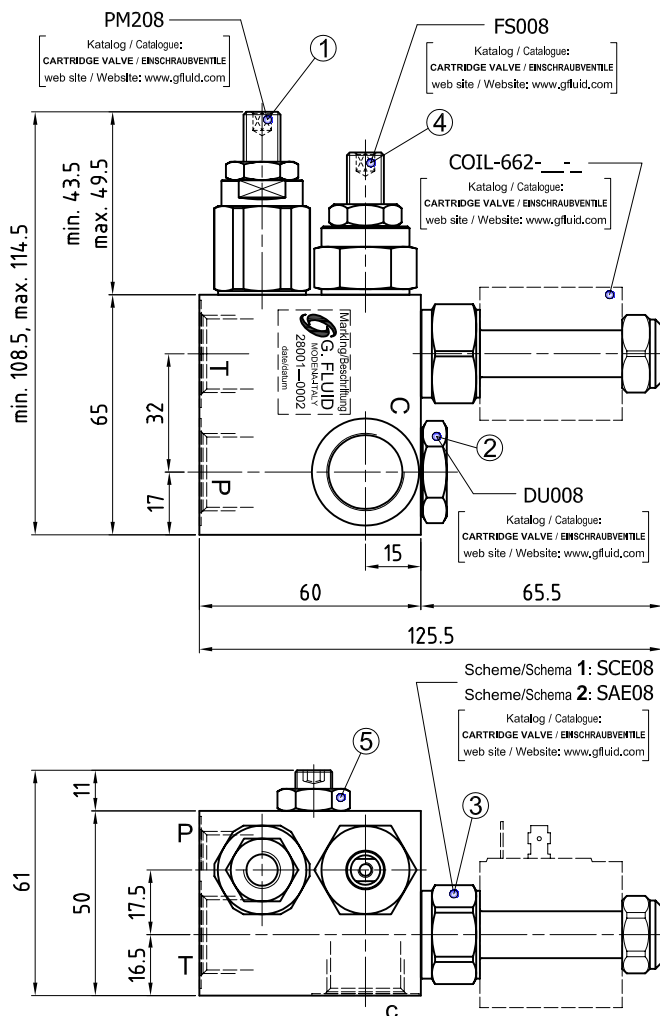
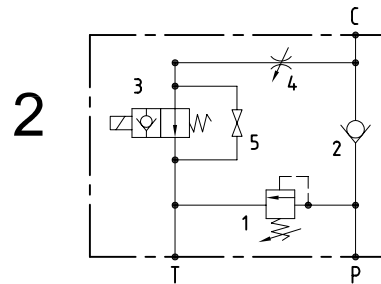

Scheme/Schema 1: SCE08
Scheme/Schema 2: SAE08

ORDERING INSTRUCTIONS - BESTELLANLEITUNG

28 00 1- - - - 00 02

Scheme Schema	Port size Gewinde	Spring Feder	standard setting
1	1 G 3/8"	1 1-6 MPa	(5 MPa)
2	2 G 1/2"	2 5-20 MPa	(18 MPa)
		3 20-35 MPa	(30 MPa)

GVS-VMG31-S_E08_-VU

TECHNICAL DATA TECHNISCHE ANGABEN

Max operating pressure Maximaler Betriebsdruck	25 MPa 3555 psi
Max flow Volumenstrom	30 l/min 7.9 gpm
Temperature range Betriebstemperatur	-20°/80°C
Filtration Filtergrad	40µ
Weight Gewicht	1.3 kg
Material	Alloy Aluminium

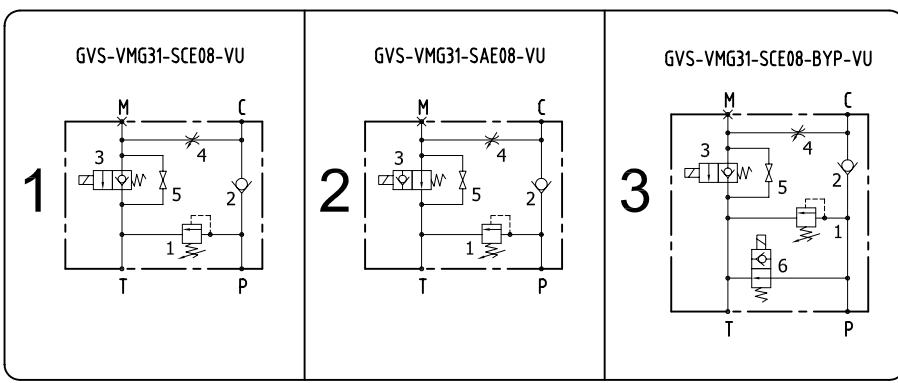

PORT SIZE GEWINDE

P, T, C	G 1/2"
M	G 1/4"

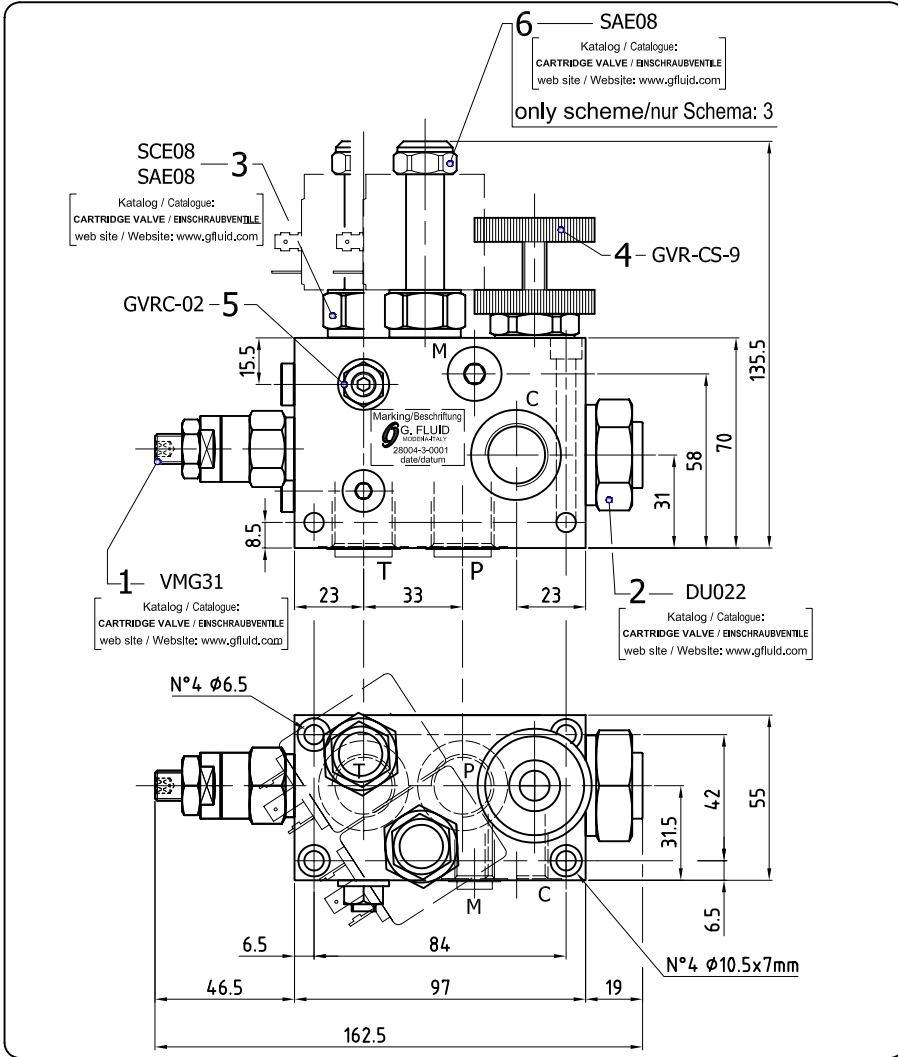

ORDERING INSTRUCTIONS - BESTELLANLEITUNG

28004 3 0001

	Scheme Schema	Spring Feder	standard setting Standardkalibrierung
1	GVS-VMG31-SCE08-VU	1 0.5-5 MPa	5 MPa
2	GVS-VMG31-SAE08-VU	3 5-21 MPa	20 MPa
3	GVS-VMG31-SCE08-BYP-VU		

GVS-GVSP150-S_E34_-VU

TECHNICAL DATA TECHNISCHE ANGABEN

Max operating pressure Maximaler Betriebsdruck	25 MPa 3626 psi
Max flow Volumenstrom	80 l/min 21.1 gpm
Temperature range Betriebstemperatur	-20°/80°C
Filtration Filtergrad	40µ
Weight Gewicht	2.6 kg
Material	Alloy Aluminium

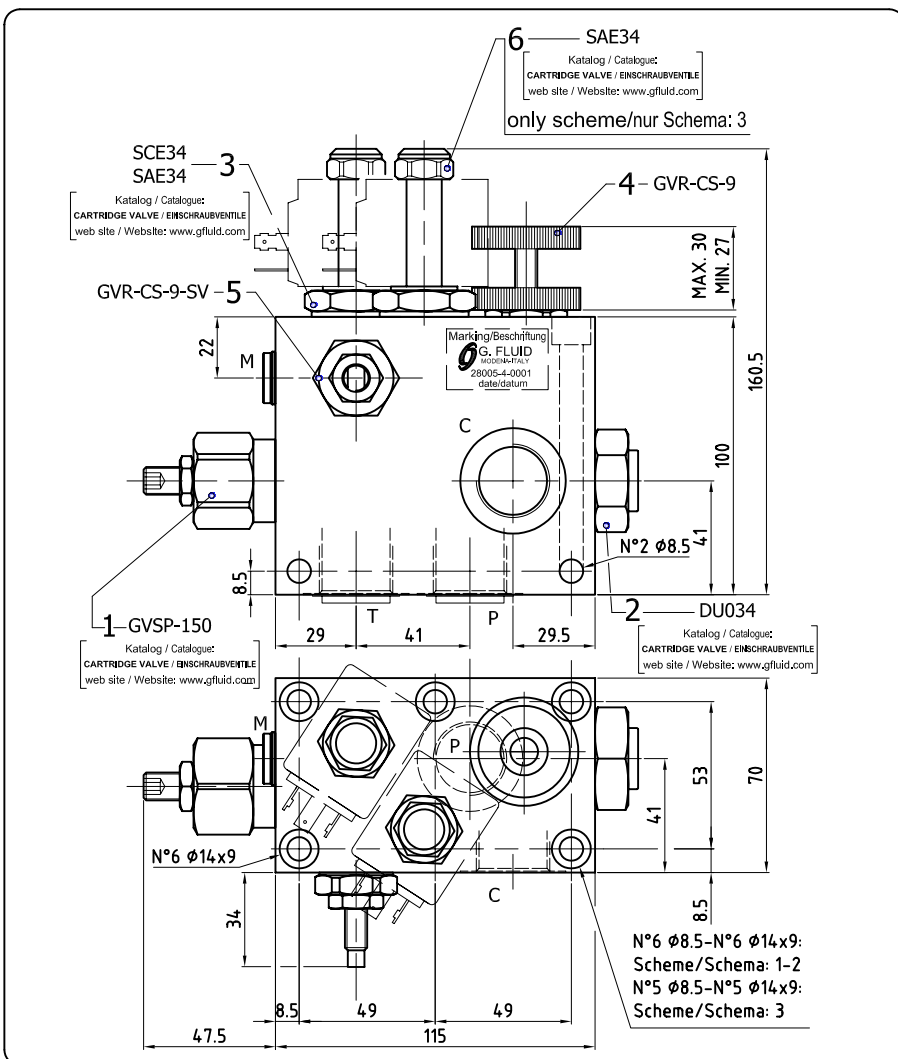
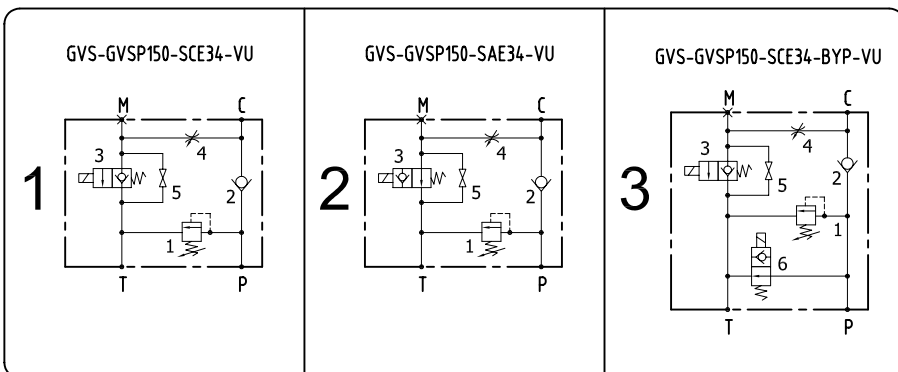

PORT SIZE GEWINDE

P, T, C	G 3/4"
M	G 1/4"

ORDERING INSTRUCTIONS - BESTELLANLEITUNG

28005 4 0001

	Scheme Schema		Spring Feder	standard setting Standardkalibrierung
1	GVS-GVSP150-SCE34-VU	2	1-14 MPa	10 MPa
2	GVS-GVSP150-SAE34-VU	3	2-25 MPa	20 MPa
3	GVS-GVSP150-SCE34-BYP-VU			

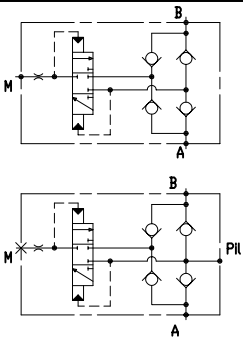
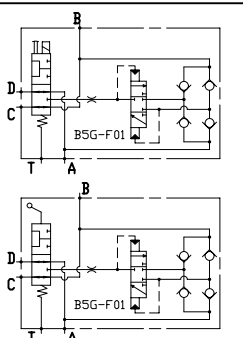
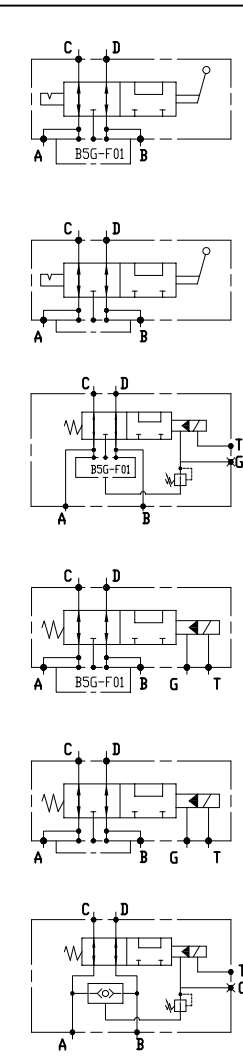
Scheme Schema	Description Bezeichnung	max flow max Durchfluß	max pressure max Arbeitsdruck	page Seite
	<p style="text-align: center;">B5G</p> <p style="text-align: center;">B5G-F01</p>	<p style="text-align: center;">60 l/min 15.8 gpm</p>	<p style="text-align: center;">42 MPa 5937 psi</p>	<p style="text-align: center;">6.001.01</p>
	<p style="text-align: center;">GSV19-B5G-F-12</p> <p style="text-align: center;">GSV19-B5G-F-L-12</p>	<p style="text-align: center;">80 l/min 21.1 gpm</p>	<p style="text-align: center;">31 MPa 4409 psi</p>	<p style="text-align: center;">6.002.01</p>
	<p style="text-align: center;">GSV25-NP-L-B5G-F-100</p> <p style="text-align: center;">GSV25-NP-L-100</p> <p style="text-align: center;">GSV25-NP-E-B5G-F-100</p> <p style="text-align: center;">GSV25-NP-D-B5G-F-100</p> <p style="text-align: center;">GSV25-NP-D-100</p> <p style="text-align: center;">GSV25-NP-E-100</p>	<p style="text-align: center;">300 l/min 79.2 gpm</p>	<p style="text-align: center;">42 MPa 5973 psi</p>	<p style="text-align: center;">6.003.01</p>

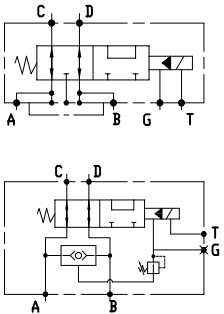
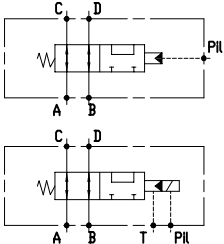
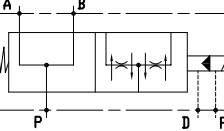
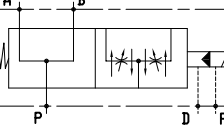
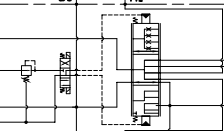
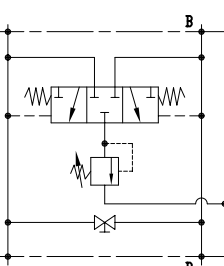
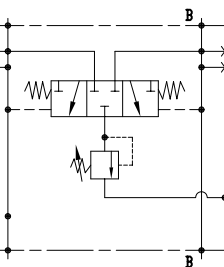
Scheme Schema	Description Bezeichnung	max flow max Durchfluß	max pressure max Arbeitsdruck	page Seite
	<p align="center">GSV25-NP-D-B5G-F-100-___-ATEX</p> <p align="center">GSV25-NP-D-F-100-___-ATEX</p>	<p align="center">300 l/min 79.2 gpm</p>	<p align="center">42 MPa 5973 psi</p>	<p align="center">6.003.02</p>
	<p align="center">GSV30-I-114</p> <p align="center">GSV30-D-114-___</p>	<p align="center">400 l/min 105.6 gpm</p>	<p align="center">42 MPa 5973 psi</p>	<p align="center">6.004.01</p>
	<p align="center">GVS-BD-107-12</p> <p align="center">GVS-BD-105-34</p>	<p align="center">100 l/min 26.4 gpm</p> <p align="center">120 l/min 31.7 gpm</p>	<p align="center">50 MPa 7112 psi</p> <p align="center">52 MPa 7396 psi</p>	<p align="center">6.009.01</p> <p align="center">6.010.01</p>
	<p align="center">GVS-BD30-07-DF-_-SAE100-34-_VDC</p> <p align="center">GVS-BD-101-1</p>	<p align="center">300 l/min 79.2 gpm</p> <p align="center">300 l/min 79.2 gpm</p>	<p align="center">45 MPa 6400 psi</p> <p align="center">42 MPa 5973 psi</p>	<p align="center">6.011.01</p> <p align="center">6.011.51</p>
	<p align="center">GVS-SPBD-202-12</p> <p align="center">GVS-SPBD-203-12</p>	<p align="center">80 l/min 21.1 gpm</p>	<p align="center">35 MPa 5076 psi</p>	<p align="center">6.020.01</p> <p align="center">6.020.02</p>
	<p align="center">GVS-HTP-01</p>	<p align="center">100 l/min 26.4 gpm</p>	<p align="center">35 MPa 5076 psi</p>	<p align="center">6.050.10</p>
	<p align="center">GVS-HTP-F02</p>	<p align="center">100 l/min 26.4 gpm</p>	<p align="center">35 MPa 5076 psi</p>	<p align="center">6.050.20</p>

B5G / B5G-F01
**TECHNICAL DATA
 TECHNISCHE ANGABEN**

Max operating pressure Maximaler Betriebsdruck	42 MPa 5973 psi
Max flow Volumenstrom	60 l/min 15.8 gpm
Temperature range Betriebstemperatur	-20°/80°C
Filtration Filtergrad	40µ
Weight Gewicht	1.8 kg
Material Material	Zincoated Steel Verzinkter Stahl

The "B5" permits a speed difference between two motors connected in series by by-passing flow from A to M or from M to B to exactly compensate for any difference in flow between the two motors.

Das B5-Ventil erlaubt es, mit 2 in Serie verbundenen Motoren mit 2 verschiedenen Geschwindigkeiten zu arbeiten, indem der Durchfluß von A nach M oder von M nach B umgeleitet wird, um die exakte Differenz der Durchfluß-Menge zwischen den beiden Motoren zu kompensieren.

Diagram/Diagramm

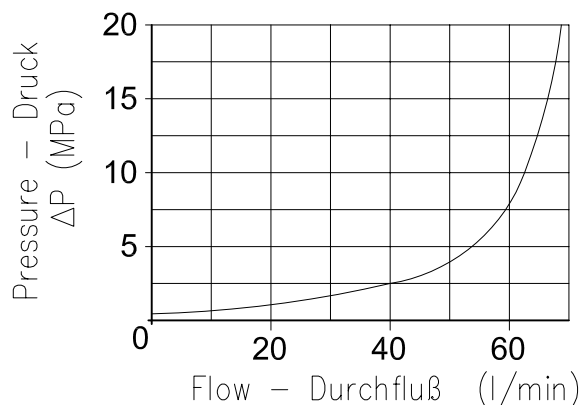
**PORT SIZE
 GEWINDE**

A, B, C, Pil

G 1/4"

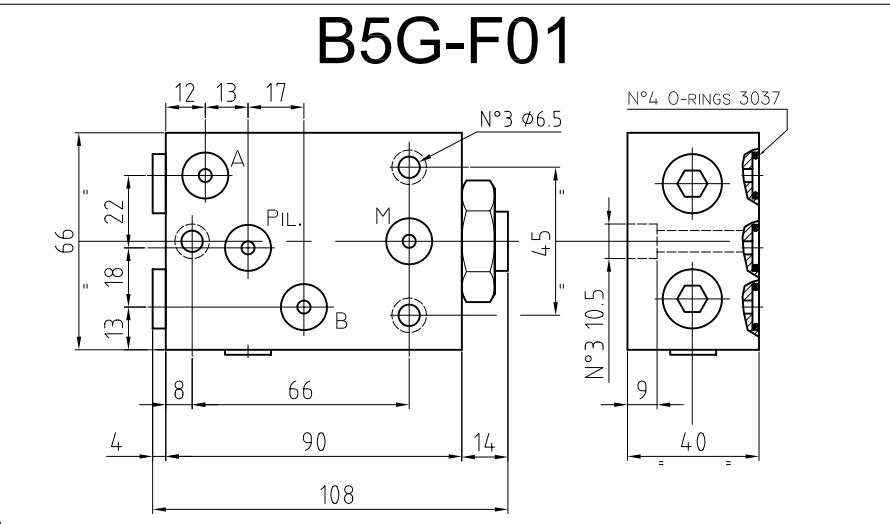
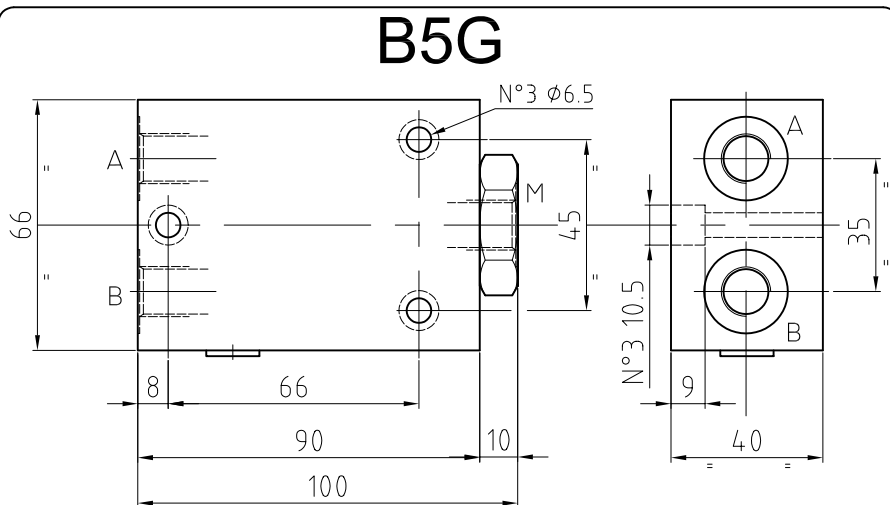
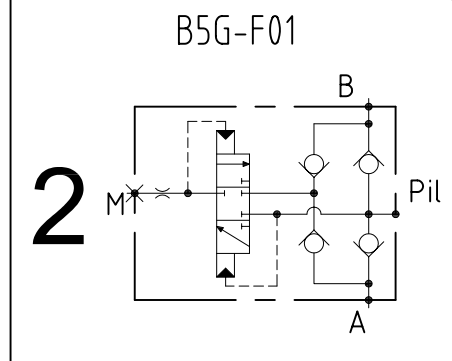
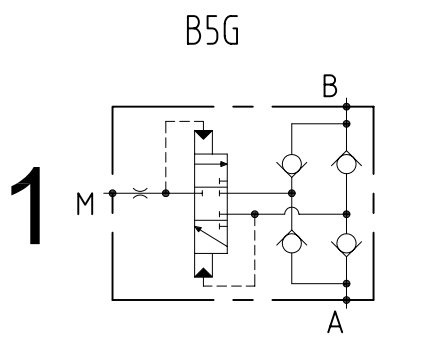
ORDERING INSTRUCTIONS - BESTELLANLEITUNG

21 00 1

-



-

00 00 00

Scheme/Schema

- 1** B5G: in line type/Ausführung mit Gewindeanschlüssen
- 2** B5G-F01: flangeable type/Ausführung zum Aufflanschen

**TECHNICAL DATA
 TECHNISCHE ANGABEN**

Max operating pressure Maximaler Betriebsdruck	31 MPa 4409 psi
Max flow Volumenstrom	80 l/min 21.1 gpm
Temperature range Betriebstemperatur	-20°/80°C
Leakage Leckölstrom	100 cm ³ /min a 10 MPa
Weight Gewicht	7.1 kg (with Lever/mit Hebel 6.5 kg)
Material Material	Zincoated Steel Verzinkter Stahl

The GSV19 directional valve enables dynamic switching from parallel to series circuit configuration to obtain a 2-speed hydraulic circuit.
 Das GSV19-Ventil erlaubt eine dynamische Umschaltung von Parallel- in Serienschaltung, um einen Hydraulik-Kreislauf mit 2 Geschwindigkeiten zu erhalten.

Old ordering instructions / Alte Bestellanleitung:

077.05.00. 0

KONTROLLE / CONTROL	
12 VDC SPANNUNG/VOLTAGE	1
24 VDC SPANNUNG/VOLTAGE	2
GSV19-B5G-F-L-12 Hebelkontrolle Lever control	L

Diagram/Diagramm

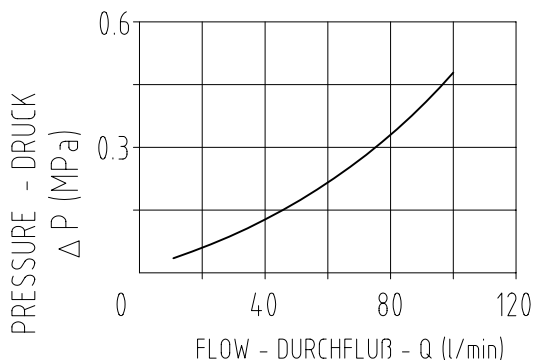

**PORT SIZE
 GEWINDE**

A, B, C, D	G 1/2"
T	G 1/4"

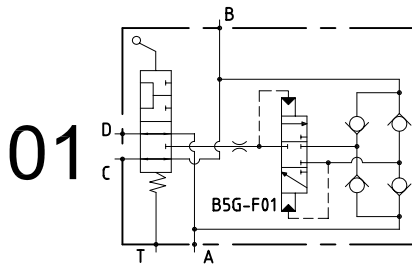
GSV19-B5G-F-L-12

01

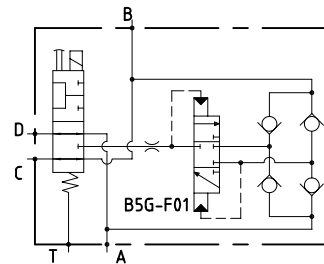
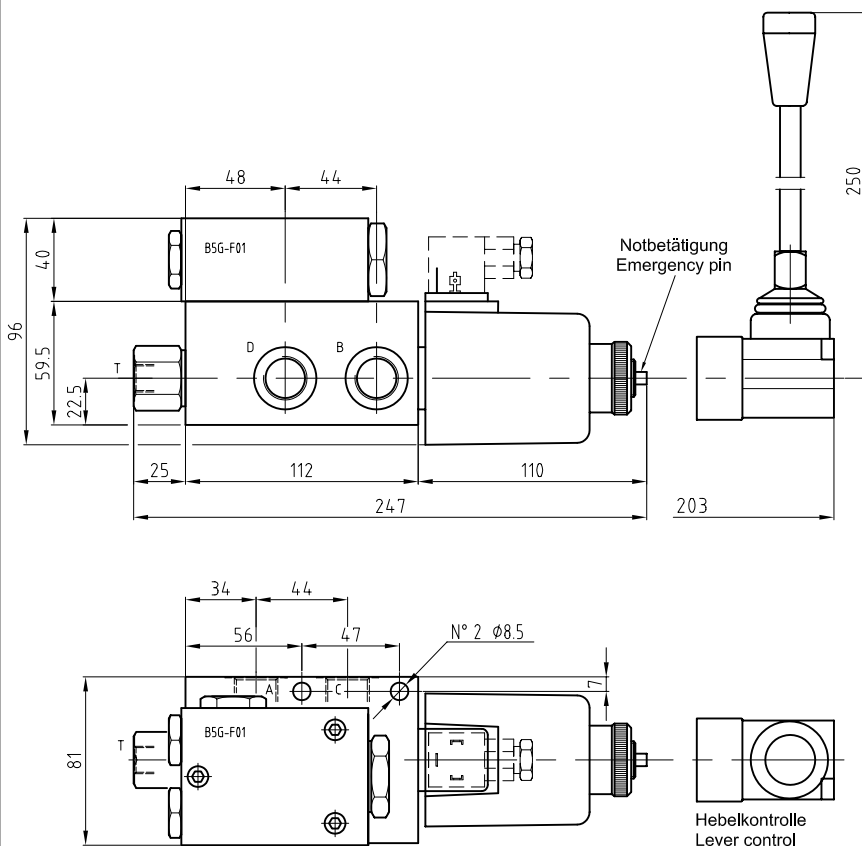
GSV19-B5G-F-12

06

ORDERING INSTRUCTIONS - BESTELLANLEITUNG
21 00 21 - **— —** - **01** - **—** - **0**

Scheme/Schema

01	GSV19-B5G-F-L-12
06	GSV19-B5G-F-12

Voltage/Spannung

0	only scheme/nur Schema: 01
1	12 VDC
2	24 VDC

**TECHNICAL DATA
 TECHNISCHE ANGABEN**

Max operating pressure Maximaler Betriebsdruck	42 MPa 5973 psi
Max flow Volumenstrom	300 l/min 79.2 gpm
Temperature range Betriebstemperatur	-20°/80°C
Filtration Filtergrad	40µ
Weight Gewicht	8.5 kg
Material Material	Zincoated Steel Verzinkter Stahl

The GSV25 directional valve enables dynamic switching from parallel to series circuit configuration to obtain a 2-speed hydraulic circuit.
 Das GSV25-Ventil erlaubt eine dynamische Umschaltung von Parallel- in Serienschaltung, um einen Hydraulik-Kreislauf mit 2 Geschwindigkeiten zu erhalten.

Diagram/Diagramm

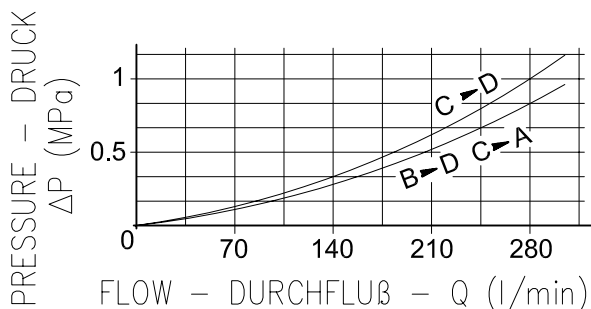

**PORT SIZE
 GEWINDE**

A, B, C, D	G 1"
T, G, Pil	G 1/4"

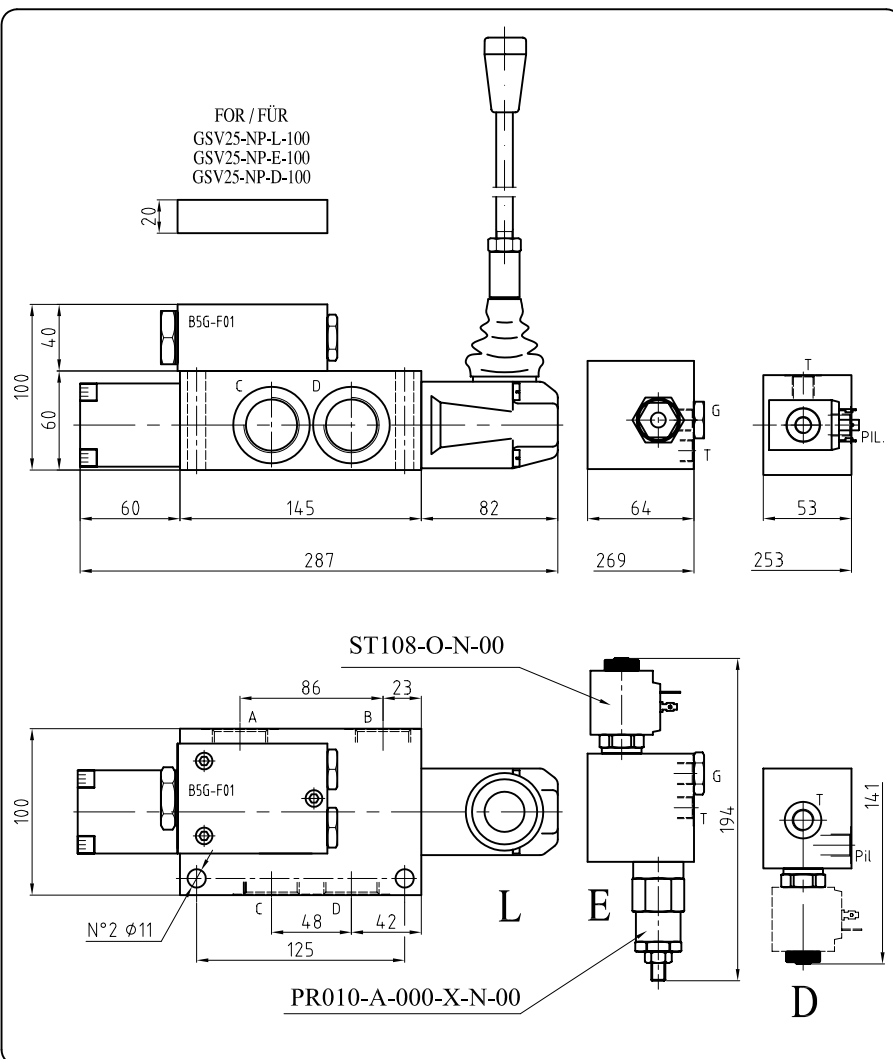
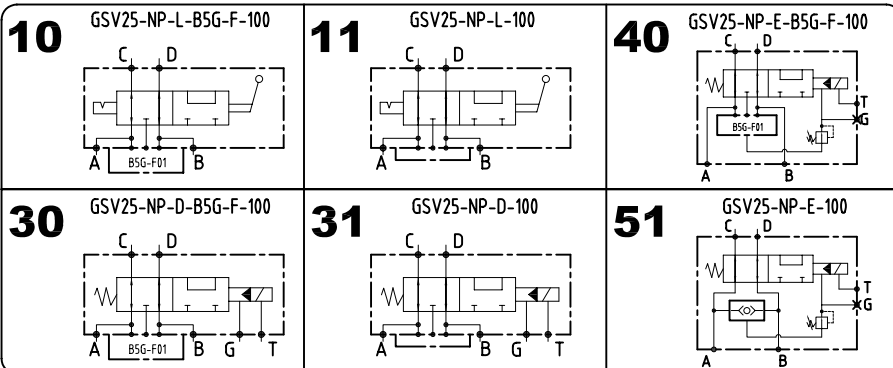

ORDERING INSTRUCTIONS - BESTELLANLEITUNG



Scheme/Schema

10	GSV25-NP-L-B5G-F-100
11	GSV25-NP-L-100
30	GSV25-NP-D-B5G-F-100
31	GSV25-NP-D-100
40	GSV25-NP-E-B5G-F-100
51	GSV25-NP-E-100

Voltage/Spannung

0	only scheme/nur Schema: 10/11
1	12 VDC
2	24 VDC

GSV25-NP-D-F-100-ATEX

TECHNICAL DATA
TECHNISCHE ANGABEN

Max operating pressure Maximaler Betriebsdruck	42 MPa 5973 psi
Max flow Volumenstrom	300 l/min 79.2 gpm
Temperature range Betriebstemperatur	-20°/80°C
Filtration Filtergrad	40µ
Weight Gewicht	8.5 kg
Material Material	Zincoated Steel Verzinkter Stahl

The GSV25 directional valve enables dynamic switching from parallel to series circuit configuration to obtain a 2-speed hydraulic circuit.
 Das GSV25-Ventil erlaubt eine dynamische Umschaltung von Parallel- in Serienschaltung, um einen Hydraulik-Kreislauf mit 2 Geschwindigkeiten zu erhalten.

SJ108:
Explosion-Proof protection:

- EEx d IIC T6 according to CENELC EN 50014 and EN 50018
- Ex II 2 G according to ATEX 94/9/CE

Electrical construction approved and certified by CESI with conformity certificate CES 03 ATEX 212

Explosionsschutz:

- EEx d IIC T6 nach CENELC EN 50014 und EN 50018
- Ex II 2 G nach ATEX 94/9/CE

Elektrische Konstruktion von CESI anerkannt und zertifiziert (Konformitätszertifikat CESI 03 ATEX 212)

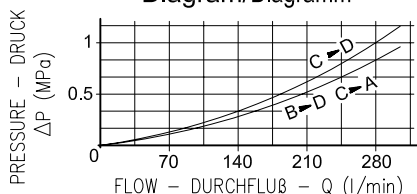
Diagram/Diagramm

PORT SIZE/GEWINDE

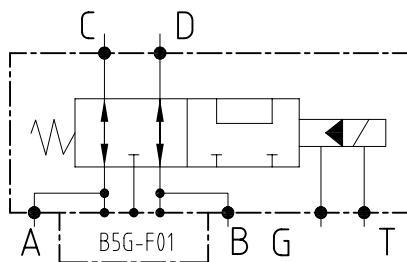
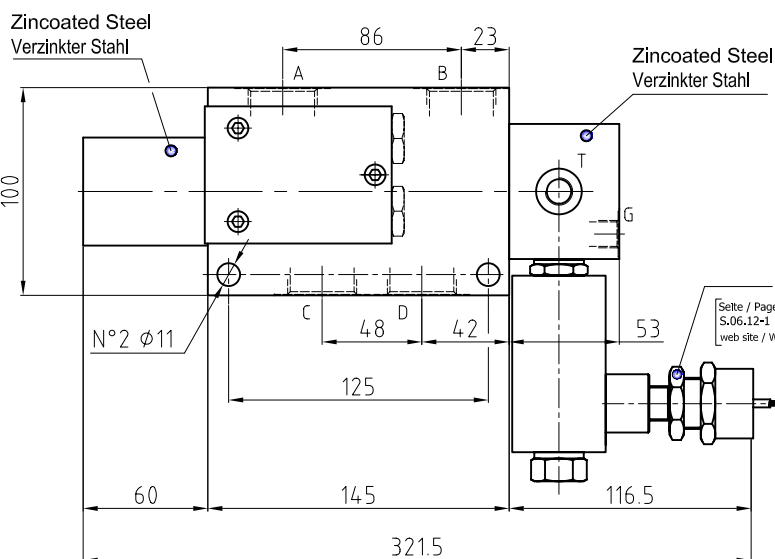
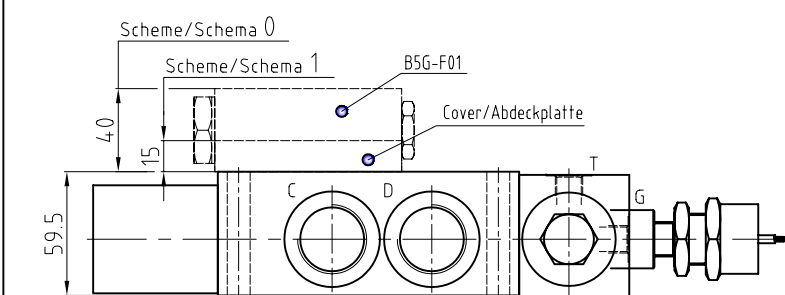
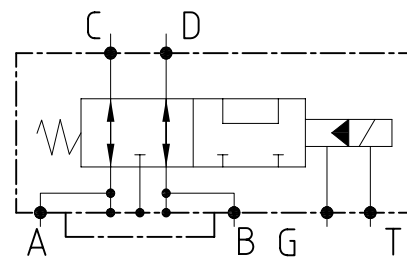
A, B, C, D	G 1"
T, G	G 1/4"

0 12V: GSV25-NP-D-B5G-F-100-12V-ATEX
 24V: GSV25-NP-D-B5G-F-100-24V-ATEX

1 12V: GSV25-NP-D-F-100-12V-ATEX
 24V: GSV25-NP-D-F-100-24V-ATEX

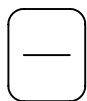
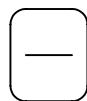
SJ108

 [Seite / Page Katalog / Catalogue]
 S.06.12-1 GFC004-11-04
 web site / Websites: www.gfluid.com

ORDERING INSTRUCTIONS - BESTELLANLEITUNG

21 00 22 03
-

-
3
-

-
1
Scheme/Schema

- | | |
|----------|-----------------------------|
| 0 | with/mit B5G-F01 |
| 1 | with/mit Cover/Abdeckplatte |

Voltage/Spannung

- | | |
|----------|--------|
| 1 | 12 VDC |
| 2 | 24 VDC |

**TECHNICAL DATA
 TECHNISCHE ANGABEN**

Max operating pressure Maximaler Betriebsdruck	42 MPa 5973 psi
Max flow Volumenstrom	400 l/min 105.6 gpm
Temperature range Betriebstemperatur	-20°/80°C
Filtration Filtergrad	40µ
Weight Gewicht	14 kg
Material Material	Zincoated Steel Verzinkter Stahl

The GSV30 directional valve enables dynamic switching from parallel to series circuit configuration to obtain a 2-speed hydraulic circuit.

Das GSV30-Ventil erlaubt eine dynamische Umschaltung von Parallel- in Serienschaltung, um einen Hydraulik-Kreislauf mit 2 Geschwindigkeiten zu erhalten.

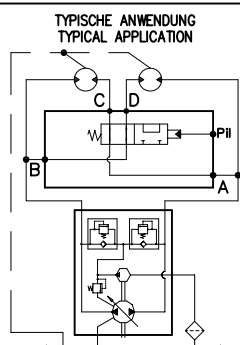
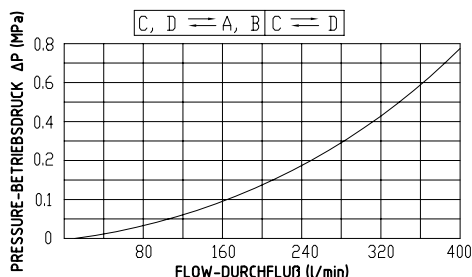
Diagram/Diagramm

**PORT SIZE
 GEWINDE**

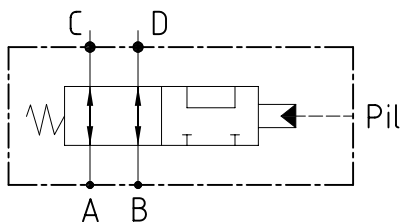
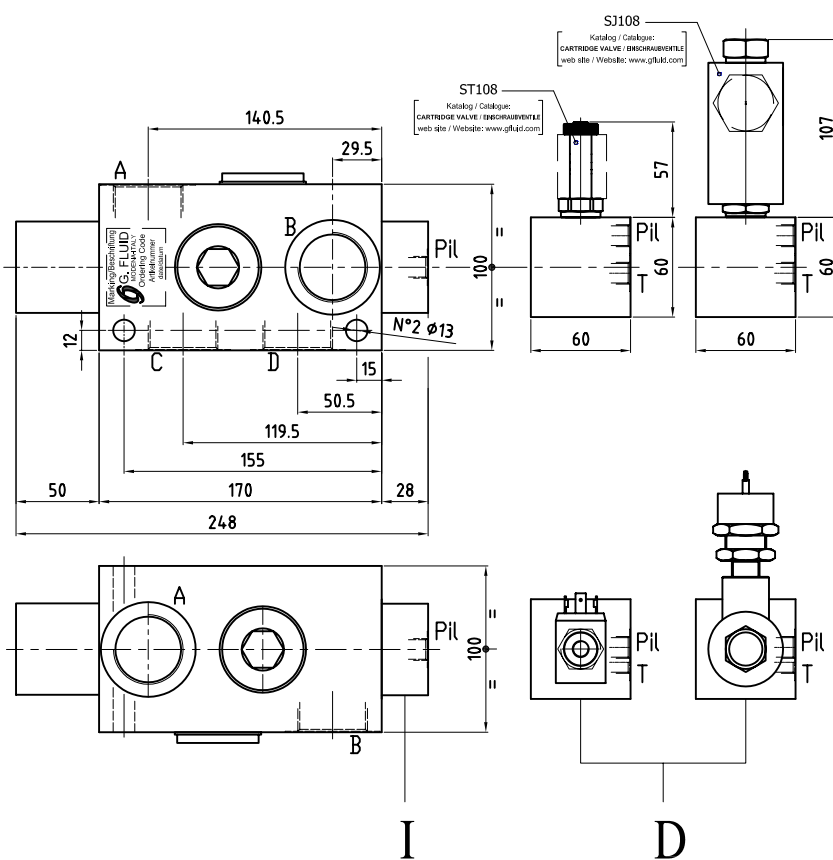
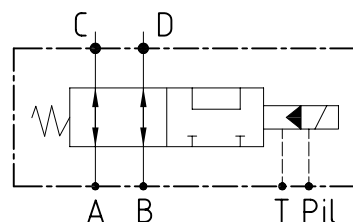
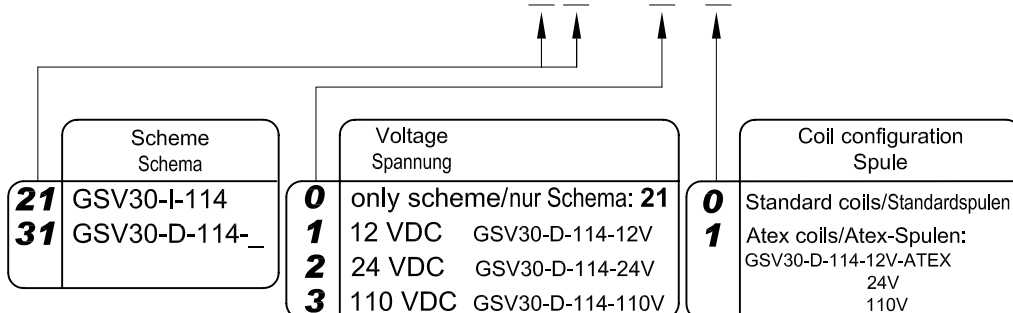
A, B, C, D	G 1" 1/4
Pil, T	G 1/4"

21 GSV30-I-114

31 GSV30-D-114-_-

ORDERING CODE - ARTIKELNUMMER
2100230 4

**TECHNICAL DATA
 TECHNISCHE ANGABEN**

Max operating pressure Maximaler Betriebsdruck	50 MPa 7112 psi
Max flow Volumenstrom	100 l/min 26.4 gpm
Temperature range Betriebstemperatur	-20°/80°C
Filtration Filtergrad	40µ
Weight Gewicht	3 kg
Material Material	Zincoated Steel Verzinkter Stahl

The differential lock valve consists principally of a double acting flow divider (dividing and combining) together with a directional flow control valve for bypassing the flow divider as desired. It is intended for the use in hydrostatic drives controlling parallel circuit hydraulic motors in both open and closed loop circuits.

Der Differenzial-Steuerblock besteht aus einem doppelt-wirkenden Stromteiler (Teilung/Vereinigung) und einem 3-Wege Elektroventil, das die parallel geschalteten Hydraulik-Motoren sowohl bei geschlossenem als auch bei geöffnetem Kreislauf kontrolliert

Diagram/Diagramm

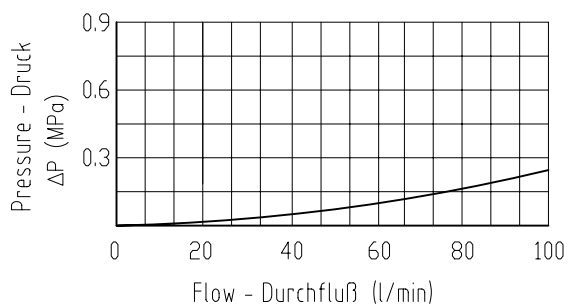
**PORT SIZE
 GEWINDE**

P	G 3/4"
A, B	G 1/2"
D, Pil	G 1/4"

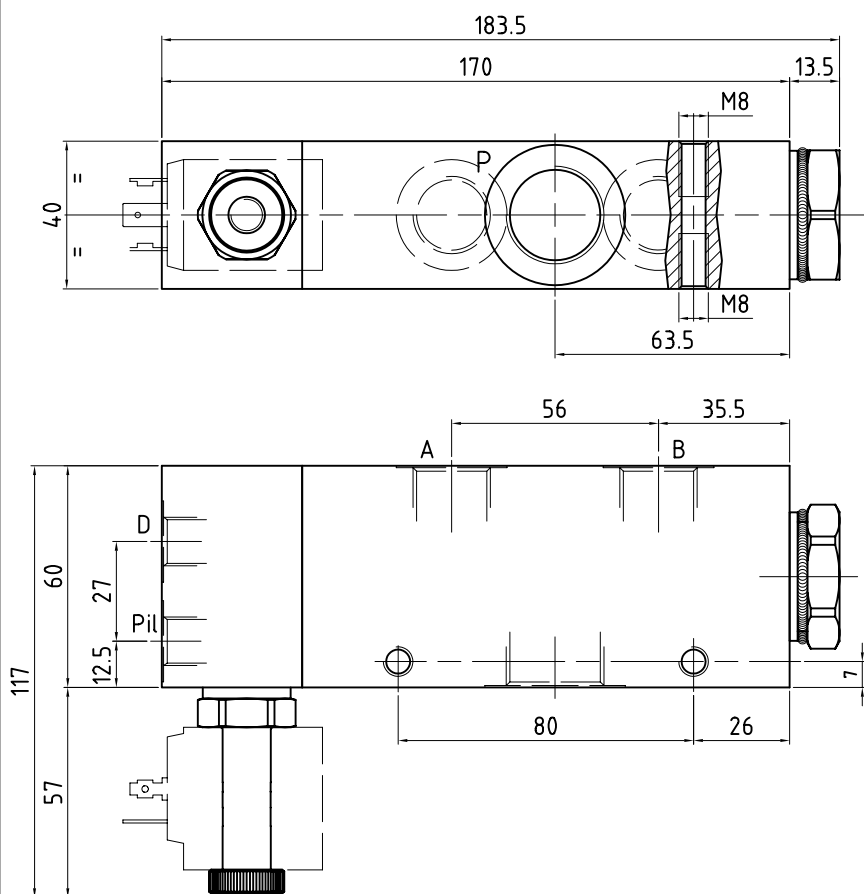
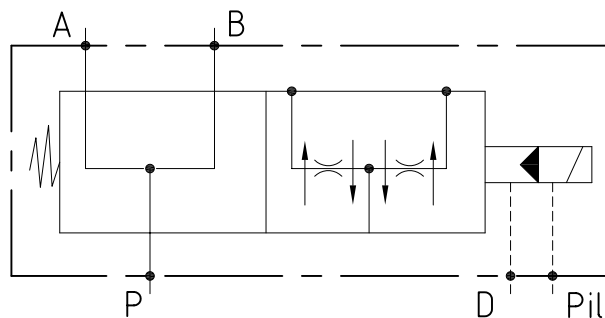
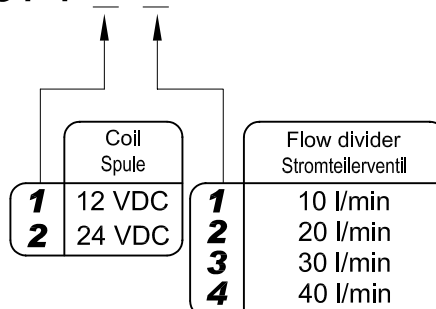

ORDERING CODE - ARTIKELNUMMER
2100311071

TECHNICAL DATA
TECHNISCHE ANGABEN

Max operating pressure Maximaler Betriebsdruck	52 MPa 7396 psi
Max flow Volumenstrom	120 l/min 31.7 gpm
Temperature range Betriebstemperatur	-20°/80°C
Filtration Filtergrad	40µ
Weight Gewicht	5.4 kg
Material Material	Zincoated Steel Verzinkter Stahl

The differential lock valve consists principally of a double acting flow divider (dividing and combining) together with a directional flow control valve for bypassing the flow divider as desired. It is intended for the use in hydrostatic drives controlling parallel circuit hydraulic motors in both open and closed loop circuits.

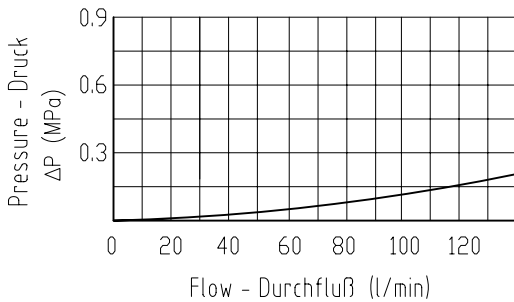
Der Differenzial-Steuerblock besteht aus einem doppelt-wirkenden Stromteiler (Teilung/Vereinigung) und einem 3-Wege Elektroventil, das die parallel geschalteten Hydraulik-Motoren sowohl bei geschlossenem als auch bei geöffnetem Kreislauf kontrolliert

Diagram/Diagramm

PORT SIZE
GEWINDE

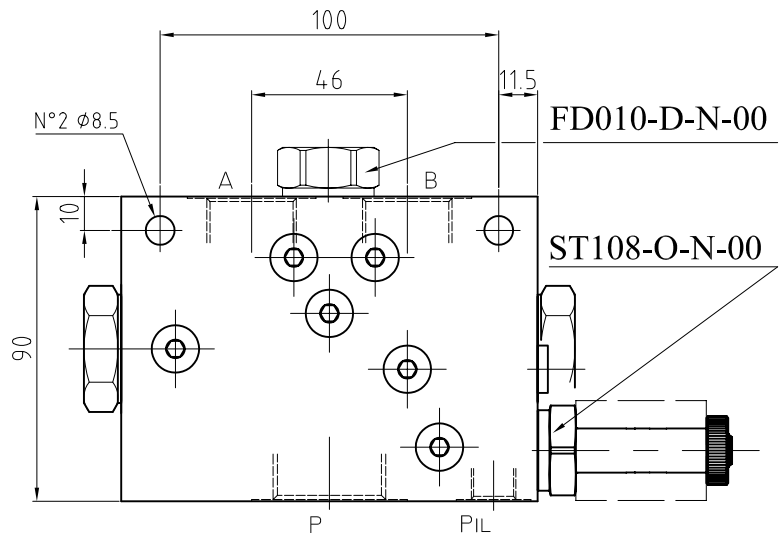
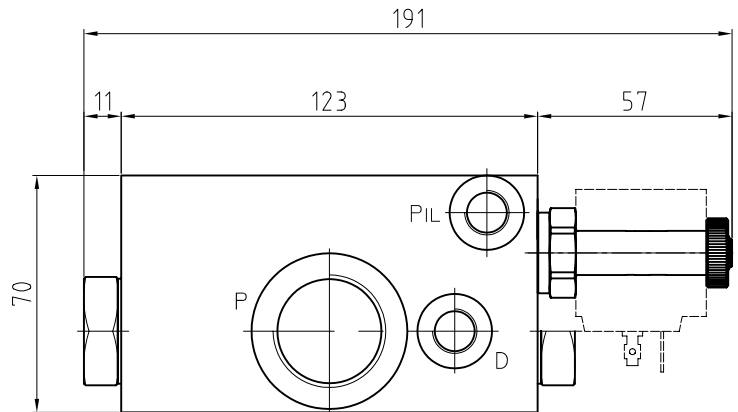
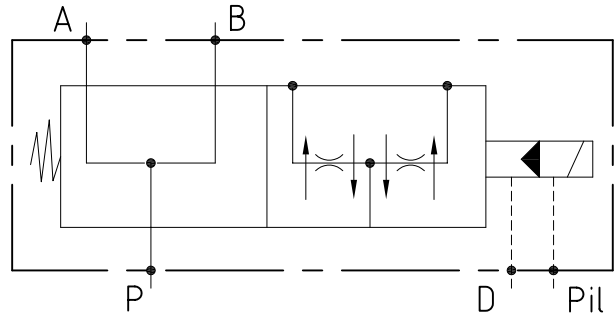
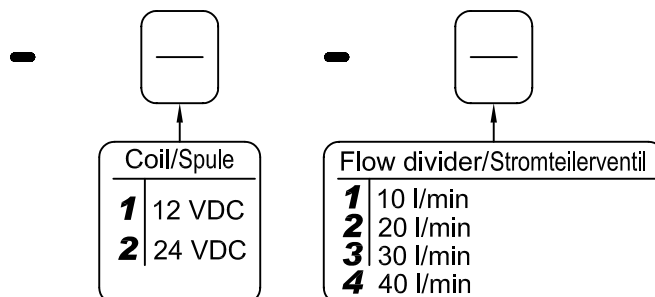
P	G 1"
A, B	G 3/4"
D, Pil	G 1/4"

ORDERING INSTRUCTIONS - BESTELLANLEITUNG
21 00 32 10 52

TECHNICAL DATA
TECHNISCHE ANGABEN

Max operating pressure Maximaler Betriebsdruck	45 MPa 6400 psi
Max flow Volumenstrom	300 l/min 79.2 gpm
Temperature range Betriebstemperatur	-20°/80°C
Filtration Filtergrad	40µ
Weight Gewicht	14.5 kg
Material Material	Zinc coated Steel Verzinkter Stahl

The differential lock valve consists principally of a double acting flow divider (dividing and combining) together with a directional valve for bypassing the flow divider as desired. It is intended for use in hydrostatic drivers controlling circuit hydraulic motors in both open and closed loop circuits.
 Der Differenzial-Steuerblock besteht aus einem doppelt-wirkenden Stromteiler (Teilung/Vereinigung) und einem 3-Wege Elektroventil, das die parallel geschalteten Hydraulik-Motoren sowohl bei geschlossenem als auch bei geöffnetem Kreislauf kontrolliert

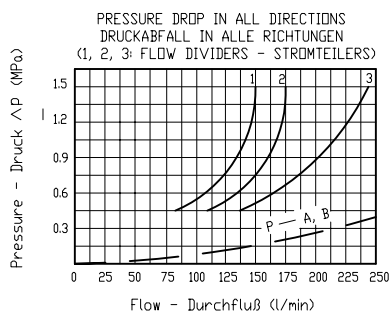
Diagram/Diagramm

PORT SIZE
GEWINDE

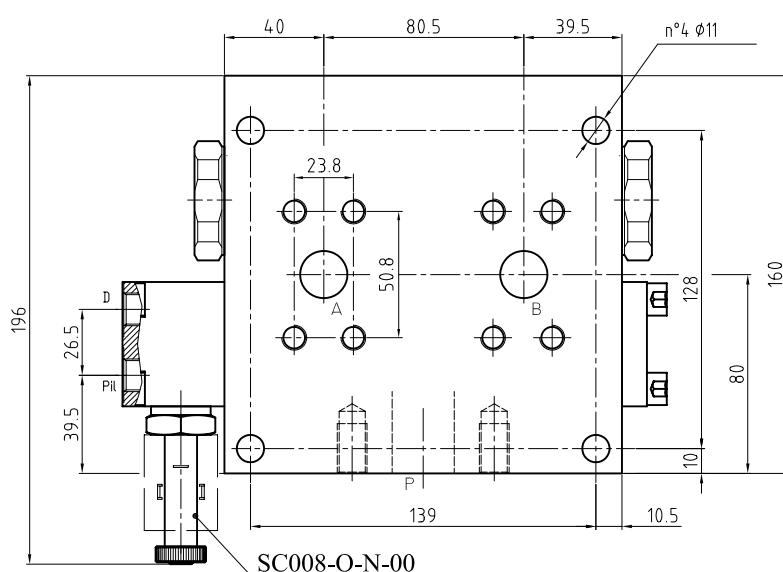
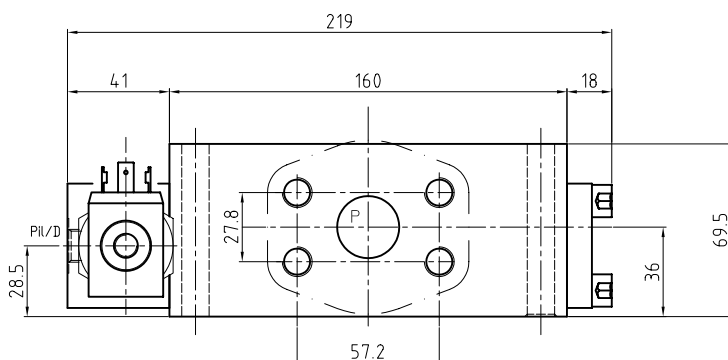
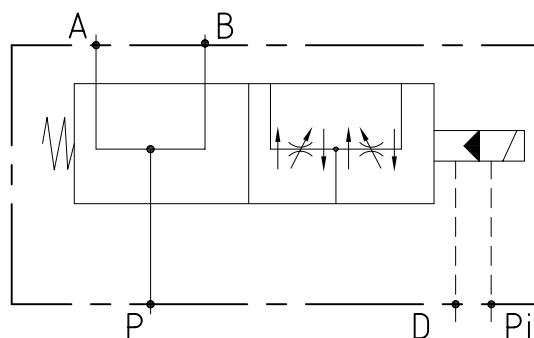
P	1" SAE 6000
A, B	3/4" SAE 6000
D, Pil	G 1/4"



ORDERING INSTRUCTIONS - BESTELLANLEITUNG
500GS03207

-	-	-
↑	↑	↑
Inlet capacity (max admitted slippage ±3%)/ Empfohlener Einstellbereich (max Abweichung ±3%)		Coil/Spule
1 90±150 l/min 2 130±180 l/min 3 180±250 l/min		1 12 VDC 2 24 VDC

**TECHNICAL DATA
TECHNISCHE ANGABEN**

Max operating pressure Maximaler Betriebsdruck	42 MPa 5973 psi
Max flow Volumenstrom	300 l/min 79.2 gpm
Temperature range Betriebstemperatur	-20°/80°C
Filtration Filtergrad	40μ
Weight Gewicht	8 kg
Material Material	Zincoated Steel Verzinkter Stahl

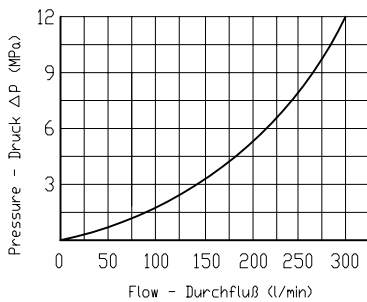
The differential lock valve consists principally of a double acting flow divider (dividing and combining) together with a directional valve for bypassing the flow divider as desired. It is intended for use in hydrostatic drivers controlling circuit hydraulic motors in both open and closed loop circuits.
Der Differenzial-Steuerblock besteht aus einem doppelt-wirkenden Stromteiler (Teilung/Vereinigung) und einem 3-Wege Elektroventil, das die parallel geschalteten Hydraulik-Motoren sowohl bei geschlossenem als auch bei geöffnetem Kreislauf kontrolliert

Diagram/Diagramm

**PORT SIZE
GEWINDE**

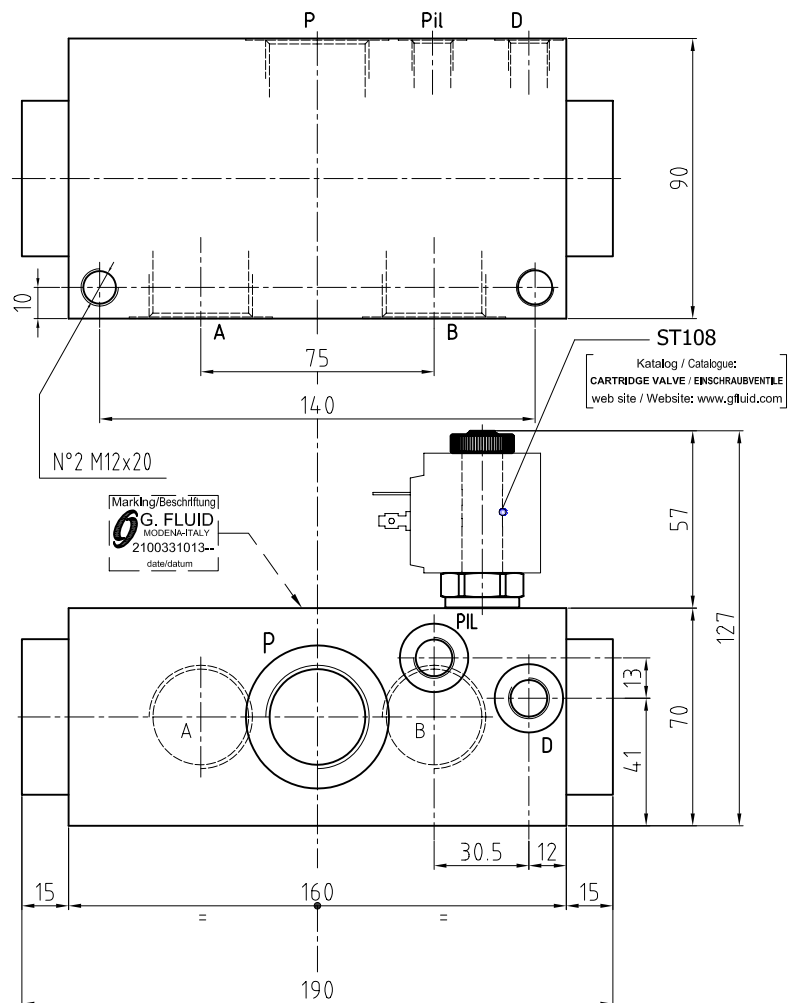
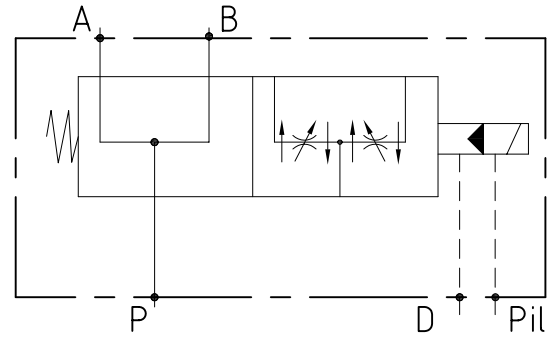
P, A, B	G 1"
D, Pil	G 1/4"

ORDERING INSTRUCTIONS - BESTELLANLEITUNG
21 00 33 10 13 - -

Coil Spule		Flow divider Stromteiler Ventil	
1	12 VDC	2	20 l/min
2	24 VDC	3	30 l/min
		4	40 l/min

GVS-SPBD-202-12

TECHNICAL DATA TECHNISCHE ANGABEN

Max operating pressure Maximaler Betriebsdruck	35 MPa 5076 psi
Max flow Volumenstrom	80 l/min 21.1 gpm
Temperature range Betriebstemperatur	-20°/80°C
Filtration Filtergrad	40µ
Weight Gewicht	15 kg
Material Material	Zincoated Steel Verzinkter Stahl

Allows the traction control from the 4 hydraulic motors by changing from a normally parallel circuit to a serial circuit for to double the velocity or to a differential circuit for the equal distribution of the flow to the motor.
 Erlaubt die Kontrolle des Antriebs der 4 Hydraulik-Motoren durch den Wechsel eines normalen parallelen Kreislauf zu einem Kreislauf in Serie, mithilfe dessen die Geschwindigkeit verdoppelt wird, oder zu einem differentiellen, der den Ölfluß gleichmäßig auf die Motoren verteilt.

ApplicationAnwendung



PORT SIZE GEWINDE

A, B	G 3/4"
A1, A2, A3, A4 B1, B2, B3, B4	G 1/2"
T	G 3/8"

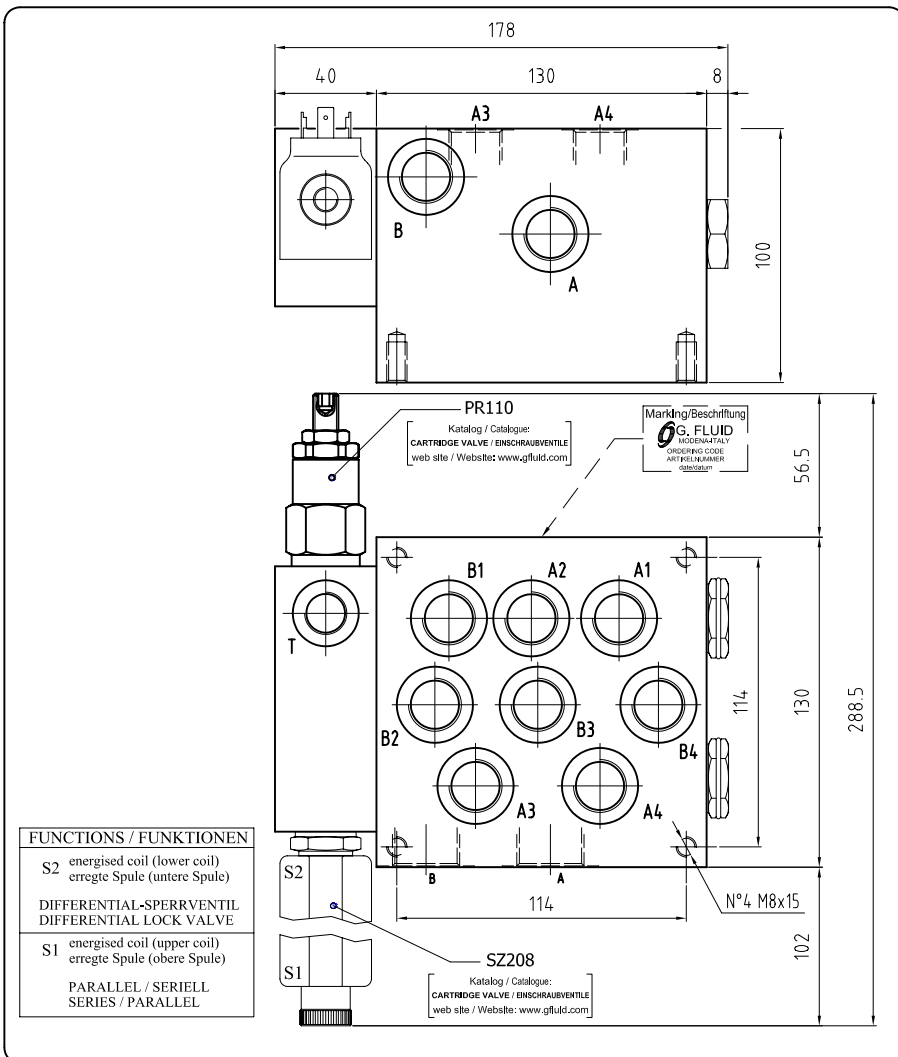
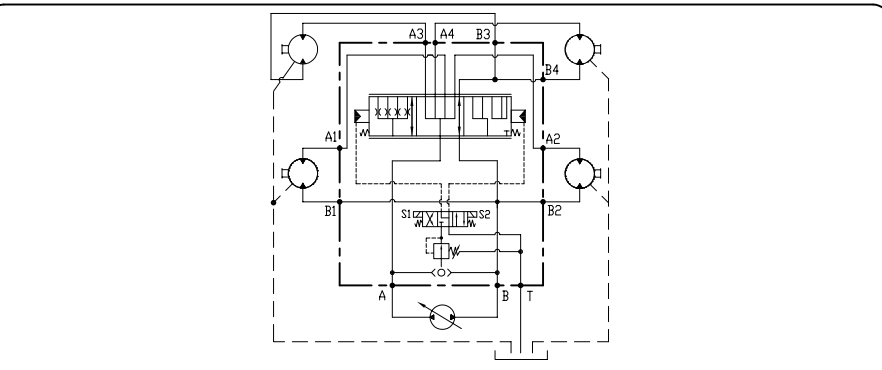

ORDERING INSTRUCTIONS - BESTELLANLEITUNG

21 00 41 20 21 _ 0

Coil Spule	
1	12 VDC
2	24 VDC

TECHNICAL DATA
TECHNISCHE ANGABEN

Max operating pressure Maximaler Betriebsdruck	35 MPa 5076 psi
Max flow Volumenstrom	80 l/min 21.1 gpm
Temperature range Betriebstemperatur	-20°/80°C
Filtration Filtergrad	40µ
Weight Gewicht	15 kg
Material Material	Zincoated Steel Verzinkter Stahl

Allows the traction control from the 4 hydraulic motors by changing from a normally parallel circuit to a serial circuit for to double the velocity or to a differential circuit for the equal distribution of the flow to the motor.
 Erlaubt die Kontrolle des Antriebs der 4 Hydraulik-Motoren durch den Wechsel eines normalen parallelen Kreislauf zu einem Kreislauf in Serie, mithilfe dessen die Geschwindigkeit verdoppelt wird, oder zu einem differentiellen, der den Ölfluß gleichmäßig auf die Motoren verteilt.

ApplicationAnwendung



PORT SIZE
GEWINDE

A, B	G 3/4"
A1, A2, A3, A4 B1, B2, B3, B4	G 1/2"
T	G 3/8"

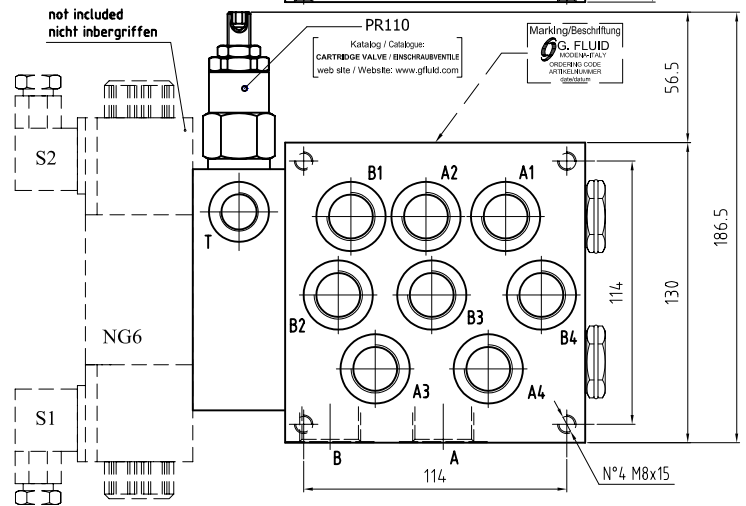
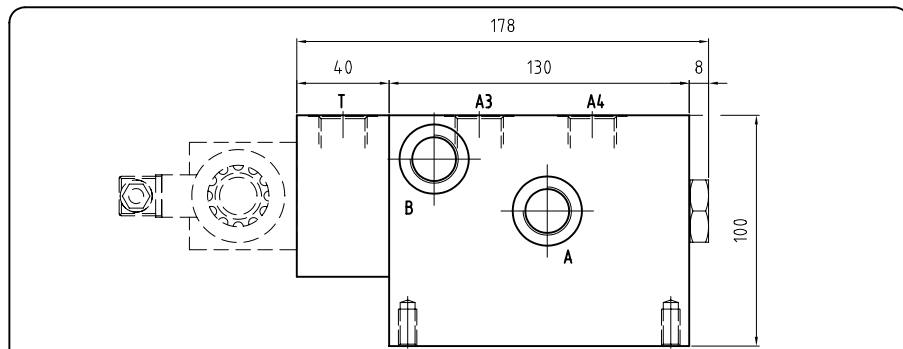
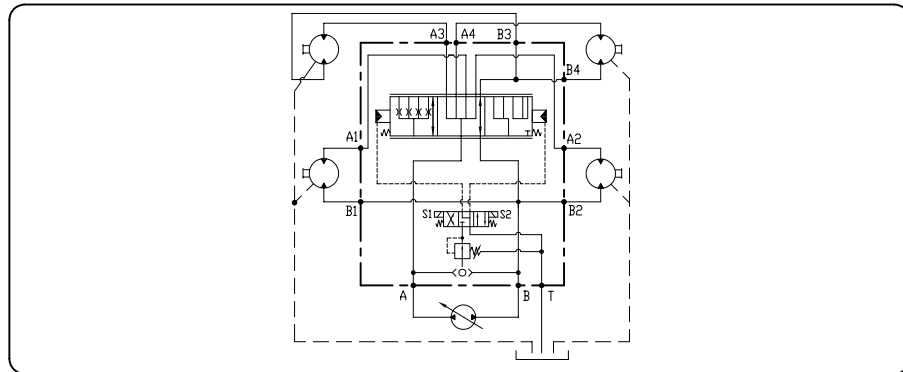

FUNCTIONS / FUNKTIONEN

S2 energised coil (lower coil)
 erregte Spule (untere Spule)

DIFFERENTIAL-SPERRVENTIL
DIFFERENTIAL LOCK VALVE

S1 energised coil (upper coil)
 erregte Spule (obere Spule)

PARALLEL / SERIELL
SERIES / PARALLEL

ORDERING CODE - ARTIKELNUMMER

210041203100

GVS-HTP-F02

TECHNICAL DATA TECHNISCHE ANGABEN

Max operating pressure Maximaler Betriebsdruck	35 MPa 5076 psi
Max flow Volumenstrom	100 l/min 26.4 gpm
Temperature range Betriebstemperatur	-20°/80°C
Filtration Filtergrad	40μ
Weight Gewicht	4.0 kg
Material Material	Zincoated Steel Verzinkter Stahl

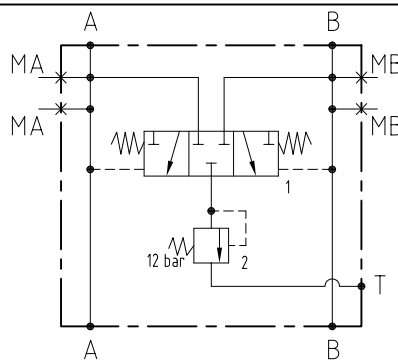

PORT SIZE GEWINDE

MA, MB, MA, MB	G 1/4"

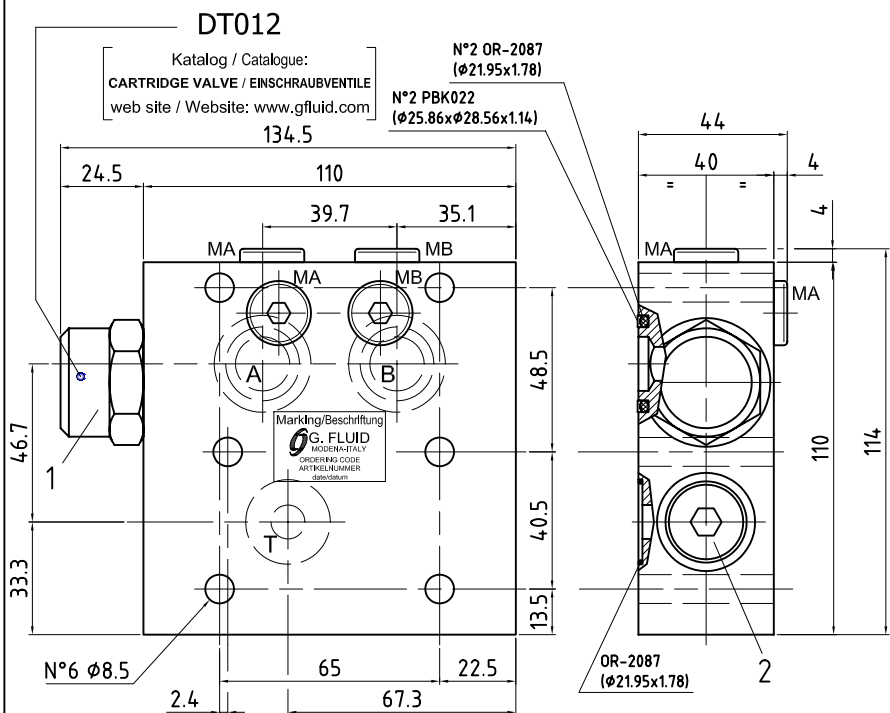

ORDERING CODE - ARTIKELNUMMER

2103102001 0

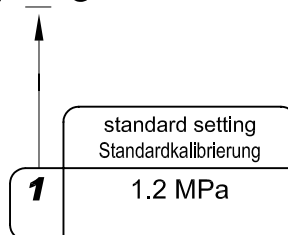

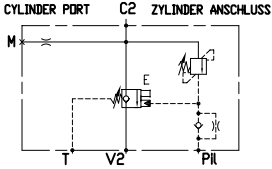
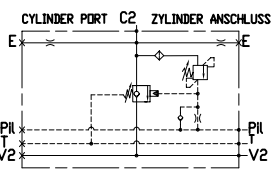
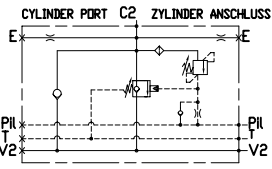
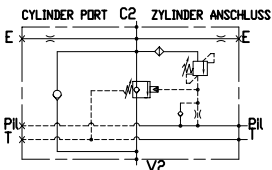
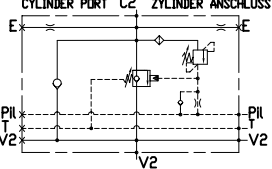
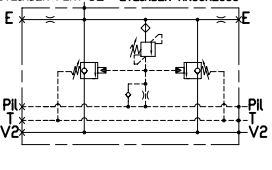
Scheme Schema	Description Bezeichnung	max flow max Durchfluß	max pressure max Arbeitsdruck	page Seite
	VMT-10-DX-__-1	40 l/min-10.5 gpm	42 MPa 5937 psi	7.005.01
	VMT-10-SX-__-1	40 l/min-10.5 gpm		7.006.01
	VMT-14-DX-__-1	100 l/min-26.4 gpm		7.010.01
	VMT-14-SX-__-1	100 l/min-26.4 gpm		7.011.01
	VMT-33-DX-__-1	150 l/min-39.6 gpm		7.015.01
	VMT-33-SX-__-1	150 l/min-39.6 gpm		7.016.01
	VMT-33-F12-1	150 l/min 39.6 gpm	42 MPa 5937 psi	7.025.01
	VMT-33-F34-__-1	250 l/min-66 gpm	42 MPa 5937 psi	7.026.01
	VMT-33-F34-027-1	250 l/min-66 gpm		7.027.01
	VMT-42-F-__-1	400 l/min-106 gpm		7.030.01
	VMT-42-F114-1	500 l/min-132 gpm		7.040.01
	VMT-42-F114-043-1	500 l/min-132 gpm		7.043.01
	VMT-33-F34-028-1	250 l/min-66 gpm	42 MPa 5937 psi	7.028.01
	VMT-42-F1-033-1	400 l/min-106 gpm		7.033.01
	VMT-42-F1-034-1	400 l/min-106 gpm		7.034.01
	VMT-42-3F1-1	400 l/min 106 gpm	42 MPa 5937 psi	7.035.01
	VMT-242-F1-1	500 l/min 132 gpm	42 MPa 5937 psi	7.050.01
	VMT-242-F114-1			7.055.01

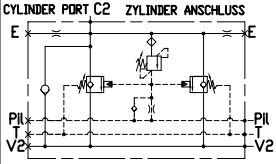
Scheme Schema	Description Bezeichnung	max flow max Durchfluß	max pressure max Arbeitsdruck	page Seite
	VMT-242-F112-1	700 l/min 172 gpm	55 MPa 7936 psi	7.060.01

VMT-10-DX-__-1

TECHNICAL DATA TECHNISCHE ANGABEN

Max operating pressure Maximaler Betriebsdruck	42 MPa 5937 psi
Max flow Volumenstrom	40 l/min 10.5 gpm
Weight Gewicht	1.8 kg
Material Material	Zinc coated steel Verzinkter Stahl

This valve, controlled by remote pilot pressure, is especially studied for direct mounting on boom cylinders of hydraulic excavators, and for use in load holding and lowering control systems designed to comply with ISO Standard 8643 (hose burst protection).

Note: The tank port must be connected to a "low pressure tank line" (to the joystick tank line, or to the tank directly).

Dieses Ventil, das durch Fernsteuerungsdruck kontrolliert wird, wurde speziell für die Montage auf Auslegerzylinder von Hydraulikbaggern zur Anwendung in Lasthalte- und Lastabsenkungskontrolle konzipiert (entsprechend ISO Standard 8643, Rohrleitungsbruchsicherung).

Anmerkung: Der Anschluß „T“ muß an eine „Niederdrucktankleitung“ (an die Joystick-Tankleitung oder direkt an den Tank) angeschlossen werden.

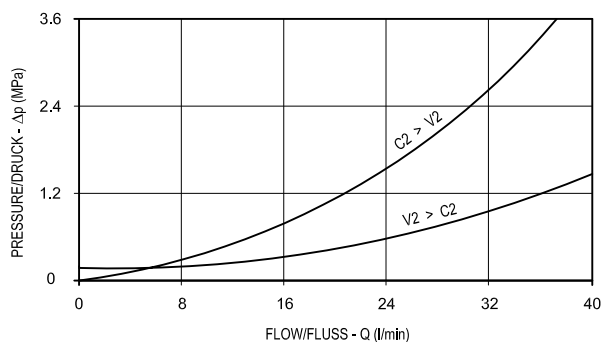

CYLINDER PORT C2 ZYLINDER ANSCHLUSS

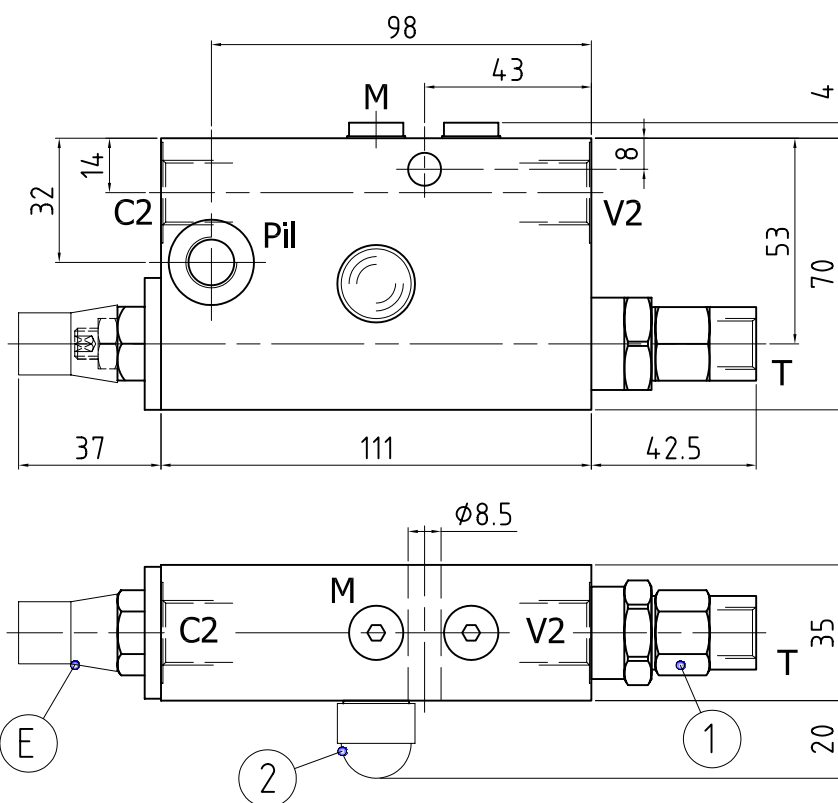
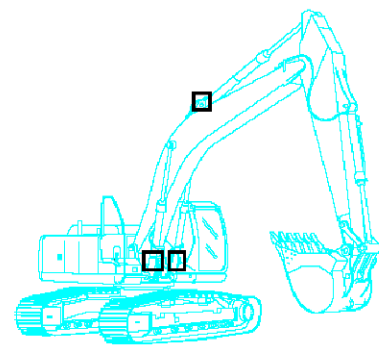
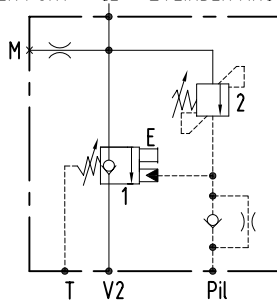

ORDERING INSTRUCTIONS - BESTELLANLEITUNG

700510 0 001

Valve Ventil	Spring pressure range Feder-Einstellbereich	Pressure increase MPa/turn Drucksteigerung MPa je Schraubendrehung	Standard setting MPa Standardeinstellung MPa	Port size - Gewinde			Description/Bezeichnung	
				V2, C2	T, Pil	M		
23	1	0.7-1.95 MPa	0.3	0.75 (cracking)	02 G 3/8"	G 1/4"	G 1/8"	VMT-10-DX-02-1
	2	20-46 MPa	22	35 (5 l/min)	92 3/8" JIS	1/4 JIS	G 1/8"	VMT-10-DX-92-1

VMT-10-SX-__1

TECHNICAL DATA TECHNISCHE ANGABEN

Max operating pressure Maximaler Betriebsdruck	42 MPa 5937 psi
Max flow Volumenstrom	40 l/min 10.5 gpm
Weight Gewicht	1.8 kg
Material Material	Zinc coated steel Verzinkter Stahl

This valve, controlled by remote pilot pressure, is especially studied for direct mounting on boom cylinders of hydraulic excavators, and for use in load holding and lowering control systems designed to comply with ISO Standard 8643 (hose burst protection).

Note: The tank port must be connected to a "low pressure tank line" (to the joystick tank line, or to the tank directly).

Dieses Ventil, das durch Fernsteuerungsdruck kontrolliert wird, wurde speziell für die Montage auf Auslegerzylinder von Hydraulikbaggern zur Anwendung in Lasthalte- und Lastabsenkungskontrolle konzipiert (entsprechend ISO Standard 8643, Rohrleitungsbruchsicherung).

Anmerkung: Der Anschluß „T“ muß an eine „Niederdrucktankleitung“ (an die Joystick-Tankleitung oder direkt an den Tank) angeschlossen werden.

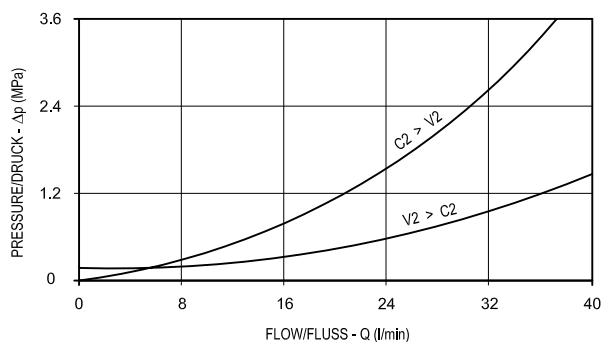

CYLINDER PORT C2 ZYLINDER ANSCHLUSS

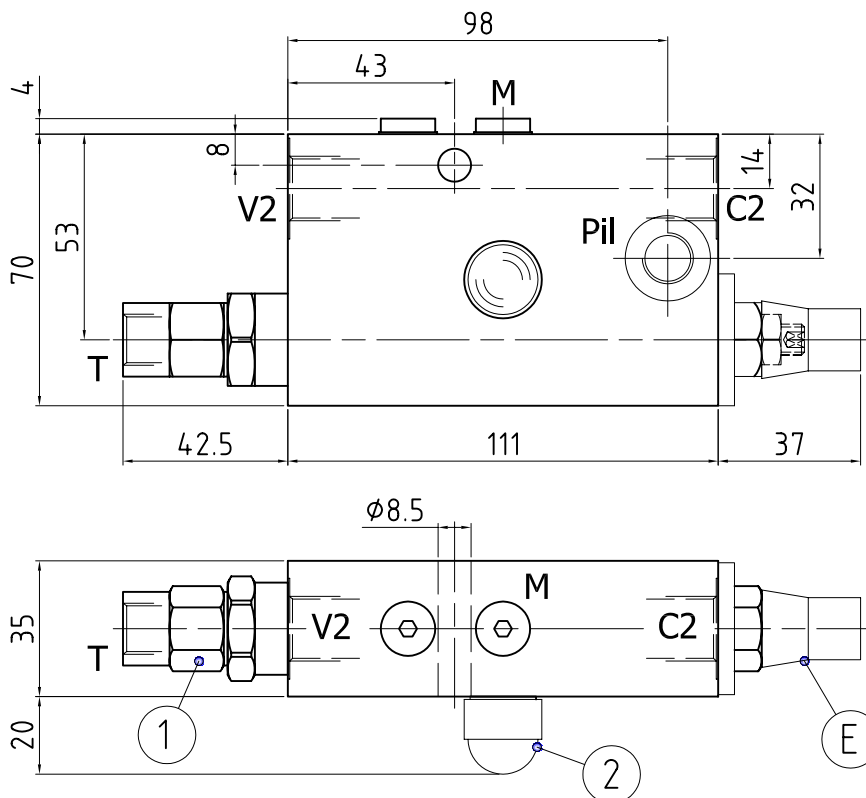
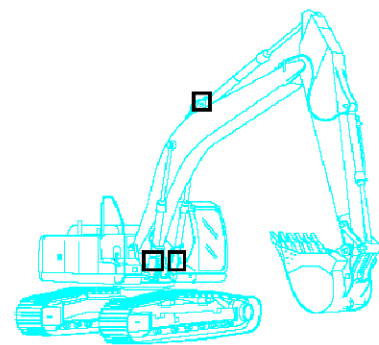
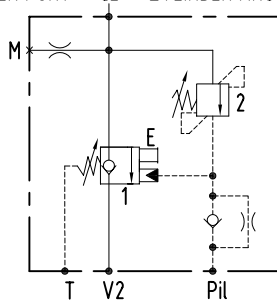

ORDERING INSTRUCTIONS - BESTELLANLEITUNG

700610 0 001

Valve Ventil	Spring pressure range Feder-Einstellbereich	Pressure increase MPa/turn Drucksteigerung MPa je Schraubendrehung	Standard setting MPa Standardeinstellung MPa	Port size - Gewinde			Description/Bezeichnung	
				V2, C2	T, Pil	M		
23	1	0.7-1.95 MPa	0.3	0.75 (cracking)	02 G 3/8"	G 1/4"	G 1/8"	VMT-10-SX-02-1
	2	20-46 MPa	22	35 (5 l/min)	92 3/8" JIS	1/4 JIS	G 1/8"	VMT-10-SX-92-1

VMT-14-DX-__-1

TECHNICAL DATA TECHNISCHE ANGABEN

Max operating pressure Maximaler Betriebsdruck	42 MPa 5937 psi
Max flow Volumenstrom	100 l/min 26.4 gpm
Weight Gewicht	2.5 kg
Material Material	Zincoated steel Verzinkter Stahl

This valve, controlled by remote pilot pressure, is especially studied for direct mounting on boom cylinders of hydraulic excavators, and for use in load holding and lowering control systems designed to comply with ISO Standard 8643 (hose burst protection).

Note: The tank port must be connected to a "low pressure tank line" (to the joystick tank line, or to the tank directly).

Dieses Ventil, das durch Fernsteuerungsdruck kontrolliert wird, wurde speziell für die Montage auf Auslegerzylinder von Hydraulikbaggern zur Anwendung in Lasthalte- und Lastabsenkungskontrolle konzipiert (entsprechend ISO Standard 8643, Rohrleitungsbruchsicherung).

Anmerkung: Der Anschluß „T“ muß an eine „Niederdrucktankleitung“ (an die Joystick-Tankleitung oder direkt an den Tank) angeschlossen werden.

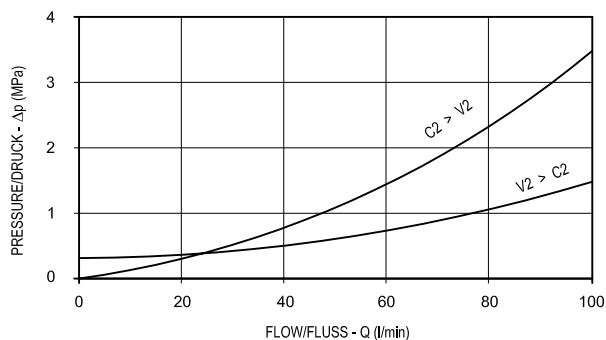

CYLINDER PORT C2 ZYLINDER ANSCHLUSS

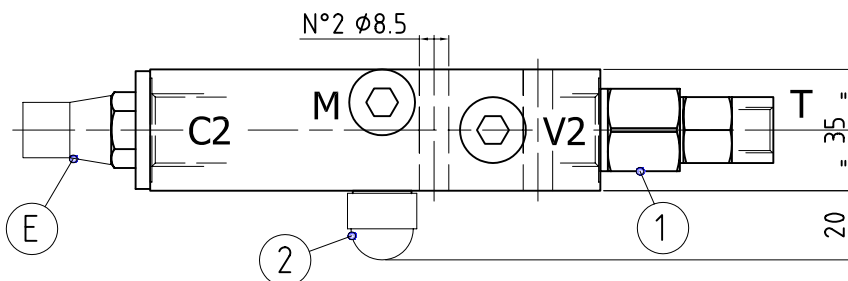
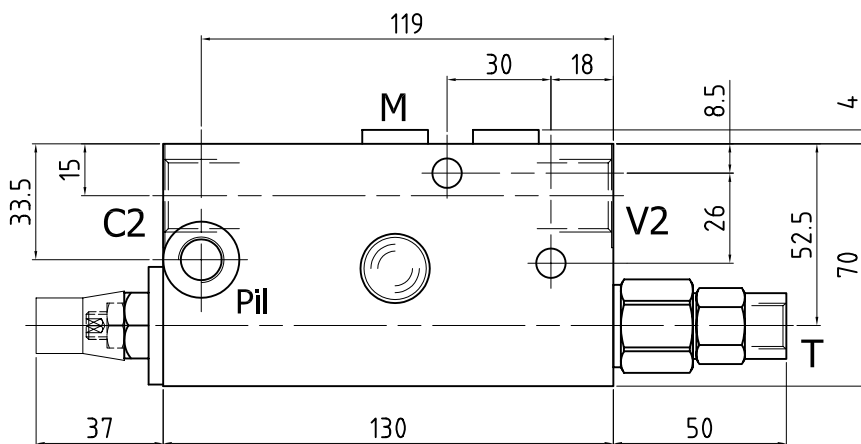
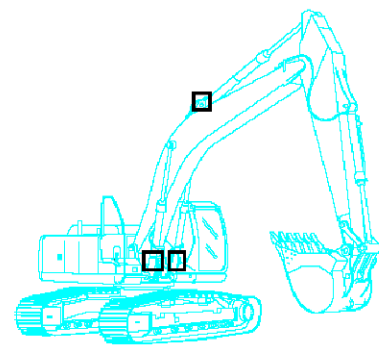
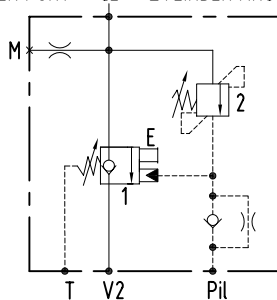

ORDERING INSTRUCTIONS - BESTELLANLEITUNG

701010 0 001

Valve Ventil	Spring pressure range Feder-Einstellbereich	Pressure increase MPa/turn Drucksteigerung MPa je Schraubendrehung	Standard setting MPa Standardeinstellung MPa	Port size - Gewinde		Description/Bezeichnung
				V2, C2	T, Pil, M	
13	1	0.3-1.5 MPa	0.35	0.75 (cracking)	03 G 1/2"	G 1/4" VMT-14-DX-03-1
	2	20-46 MPa	22	35 (5 l/min)	93 1/2" JIS	1/4 JIS VMT-14-DX-93-1

VMT-14-SX-__-1

TECHNICAL DATA TECHNISCHE ANGABEN

Max operating pressure Maximaler Betriebsdruck	42 MPa 5937 psi
Max flow Volumenstrom	100 l/min 26.4 gpm
Weight Gewicht	2.5 kg
Material Material	Zinc coated steel Verzinkter Stahl

This valve, controlled by remote pilot pressure, is especially studied for direct mounting on boom cylinders of hydraulic excavators, and for use in load holding and lowering control systems designed to comply with ISO Standard 8643 (hose burst protection).

Note: The tank port must be connected to a "low pressure tank line" (to the joystick tank line, or to the tank directly).

Dieses Ventil, das durch Fernsteuerungsdruck kontrolliert wird, wurde speziell für die Montage auf Auslegerzylinder von Hydraulikbaggern zur Anwendung in Lasthalte- und Lastabsenkungskontrolle konzipiert (entsprechend ISO Standard 8643, Rohrleitungsbruchsicherung).

Anmerkung: Der Anschluß „T“ muß an eine „Niederdrucktankleitung“ (an die Joystick-Tankleitung oder direkt an den Tank) angeschlossen werden.

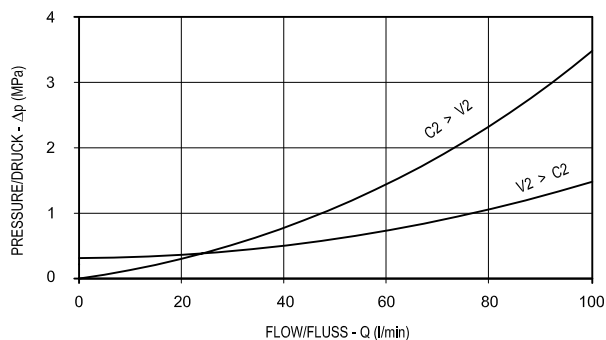

CYLINDER PORT C2 ZYLINDER ANSCHLUSS

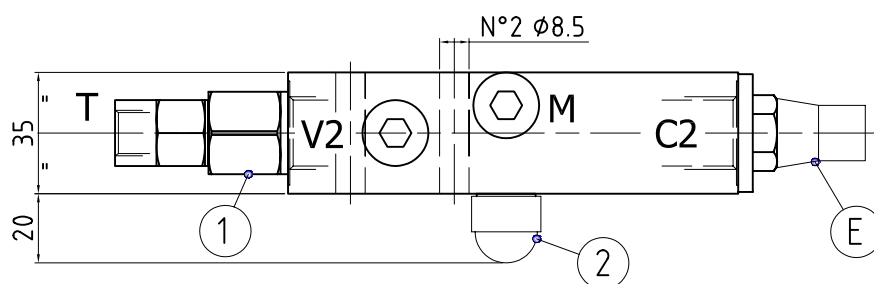
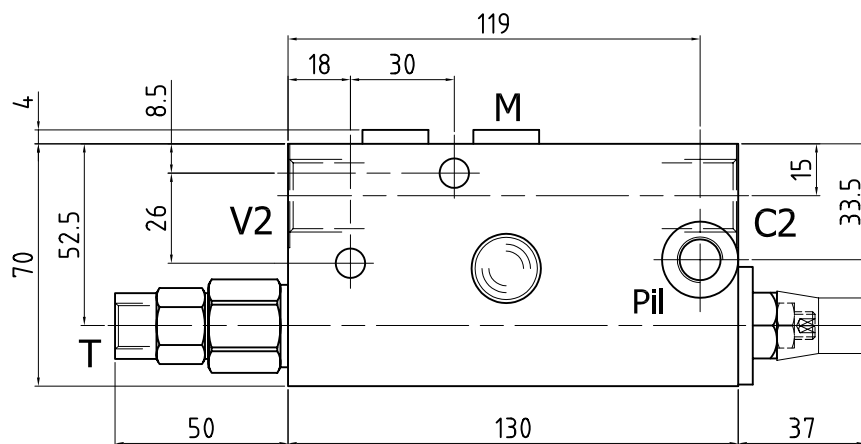
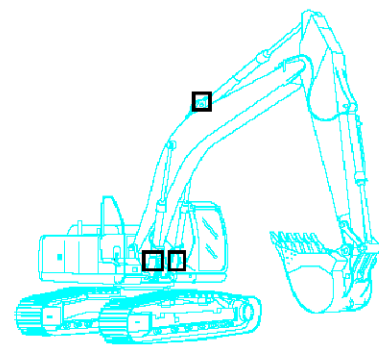
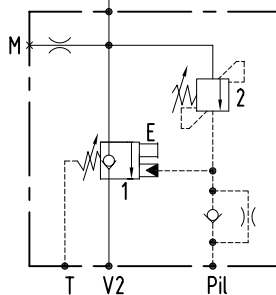

ORDERING INSTRUCTIONS - BESTELLANLEITUNG

701110 0 001

13	Valve Ventil	Spring pressure range Feder-Einstellbereich	Pressure increase MPa/turn Drucksteigerung MPa je Schraubendrehung	Standard setting MPa Standardeinstellung MPa	Port size - Gewinde		
					V2, C2	T, Pil, M	Description/Bezeichnung
03	1	0.3-1.5 MPa	0.35	0.75 (cracking)	G 1/2"	G 1/4"	VMT-14-SX-03-1
93	2	20-46 MPa	22	35 (5 l/min)	1/2" JIS	1/4 JIS	VMT-14-SX-93-1

VMT-33-DX-__-1

TECHNICAL DATA TECHNISCHE ANGABEN

Max operating pressure Maximaler Betriebsdruck	42 MPa 5937 psi
Max flow Volumenstrom	150 l/min 39.6 gpm
Temperature range Betriebstemperatur	-20°/100°C other temperature ranges on request Weitere Temperaturbereiche auf Anfrage
Filtration Filtergrad	20µ
Weight Gewicht	3.4 kg
Material	Zincoated steel Verzinkter Stahl

This valve, controlled by remote pilot pressure, is especially studied for direct mounting on boom cylinders of hydraulic excavators, and for use in load holding and lowering control systems designed to comply with ISO Standard 8643 (hose burst protection).

Note: The tank port must be connected to a "low pressure tank line" (to the joystick tank line, or to the tank directly).

Dieses Ventil, das durch Fernsteuerungsdruck kontrolliert wird, wurde speziell für die Montage auf Auslegerzylinder von Hydraulikbaggern zur Anwendung in Lasthalte- und Lastabsenkungskontrolle konzipiert (entsprechend ISO Standard 8643, Rohrleitungsbruchsicherung).

Anmerkung: Der Anschluß „T“ muß an eine „Niederdrucktankleitung“ (an die Joystick-Tankleitung oder direkt an den Tank) angeschlossen werden.

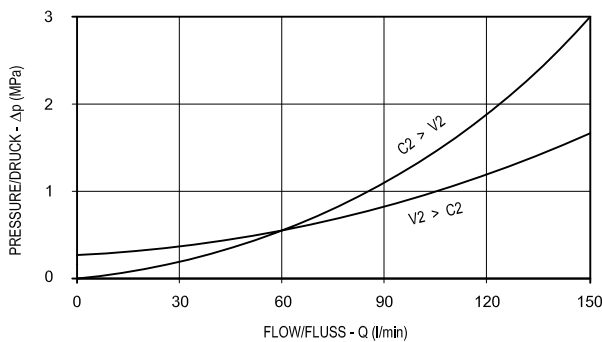

CYLINDER PORT C2 ZYLINDER ANSCHLUSS

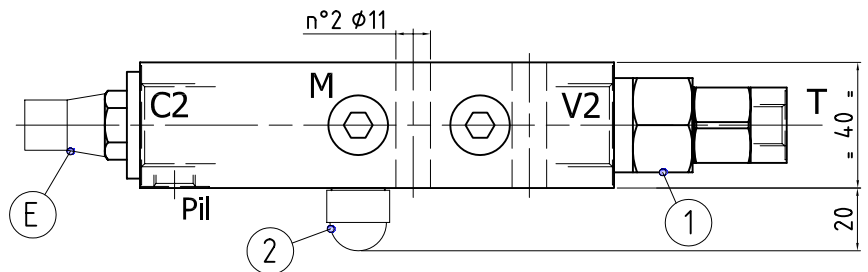
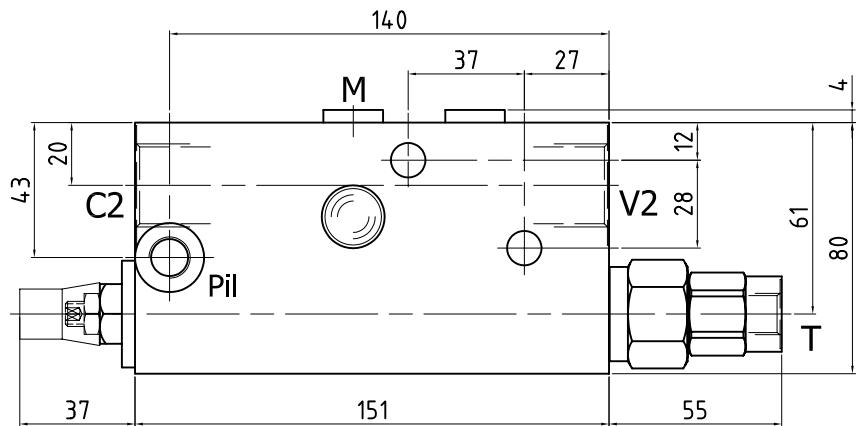
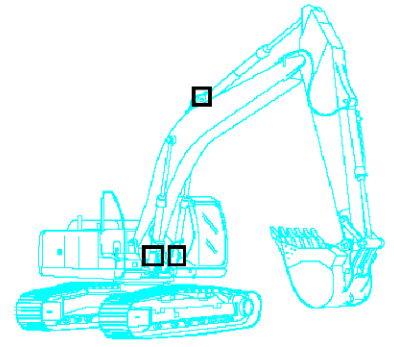
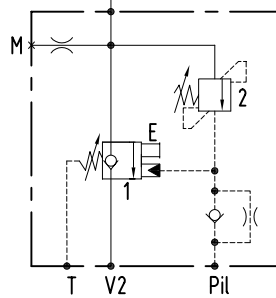

ORDERING INSTRUCTIONS - BESTELLANLEITUNG

701510 0 001

Valve Ventil	Spring pressure range Feder-Einstellbereich	Pressure increase MPa/turn Drucksteigerung MPa je Schraubendrehung	Standard setting MPa Standardeinstellung MPa
23 1	0.7-1.95 MPa	0.35	0.75 (cracking)
2	20-46 MPa	22	35 (5 l/min)

	Port size - Gewinde		Description/Bezeichnung
	V2, C2	T, Pil, M	
04	G 3/4"	G 1/4"	VMT-33-DX-04-1
46	1 1/16-12 UN-2B	9/16-18 UNF-2B	VMT-33-DX-46-1
94	3/4" JIS	1/4" JIS	VMT-33-DX-94-1

VMT-33-SX-__-1

TECHNICAL DATA TECHNISCHE ANGABEN

Max operating pressure Maximaler Betriebsdruck	42 MPa 5937 psi
Max flow Volumenstrom	150 l/min 39.6 gpm
Temperature range Betriebstemperatur	-20°/100°C other temperature ranges on request Weitere Temperaturbereiche auf Anfrage
Filtration Filtergrad	20µ
Weight Gewicht	3.4 kg
Material Material	Zincoated steel Verzinkter Stahl

This valve, controlled by remote pilot pressure, is especially studied for direct mounting on boom cylinders of hydraulic excavators, and for use in load holding and lowering control systems designed to comply with ISO Standard 8643 (hose burst protection).

Note: The tank port must be connected to a "low pressure tank line" (to the joystick tank line, or to the tank directly).

Dieses Ventil, das durch Fernsteuerungsdruck kontrolliert wird, wurde speziell für die Montage auf Auslegerzylinder von Hydraulikbaggern zur Anwendung in Lasthalte- und Lastabsenkungskontrolle konzipiert (entsprechend ISO Standard 8643, Rohrleitungsbruchsicherung).

Anmerkung: Der Anschluß „T“ muß an eine „Niederdrucktankleitung“ (an die Joystick-Tankleitung oder direkt an den Tank) angeschlossen werden.

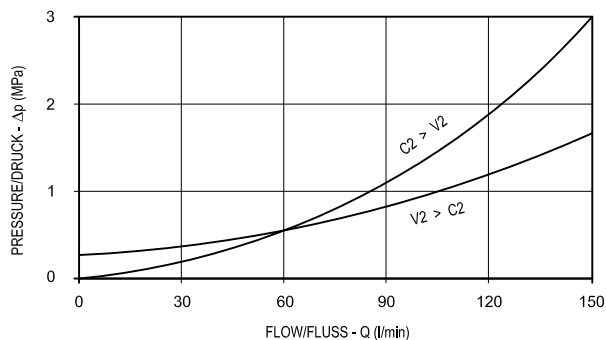

CYLINDER PORT C2 ZYLINDER ANSCHLUSS

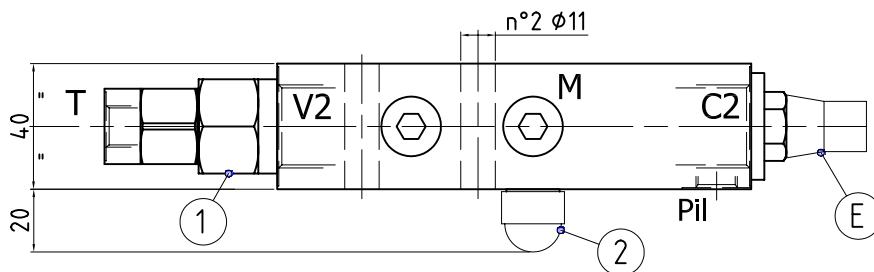
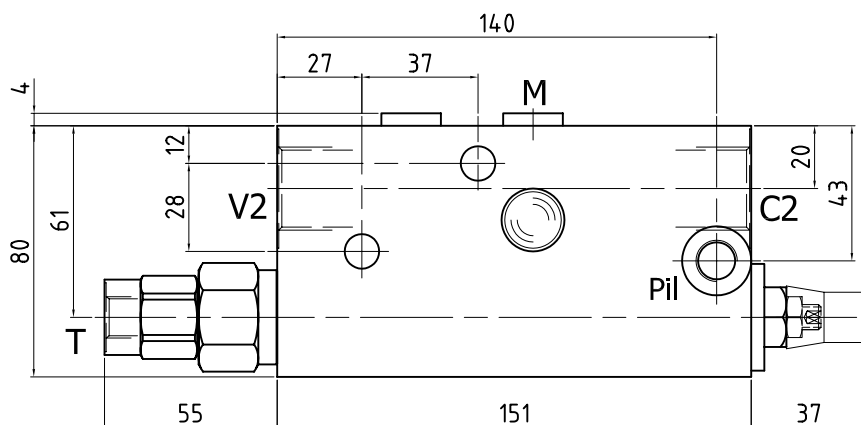
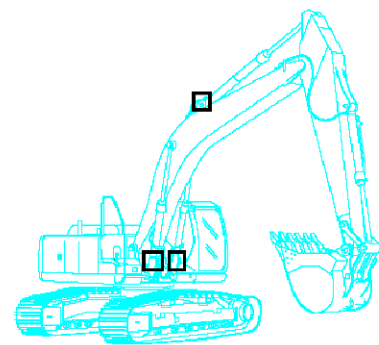
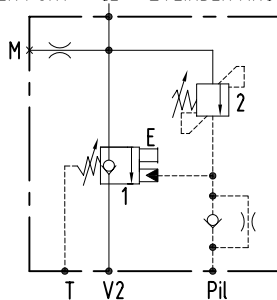

ORDERING INSTRUCTIONS - BESTELLANLEITUNG

701610 0 001

Valve Ventil	Spring pressure range Feder-Einstellbereich	Pressure increase MPa/turn Drucksteigerung MPa je Schraubendrehung	Standard setting MPa Standardeinstellung MPa
23 1	0.7-1.95 MPa	0.35	0.75 (cracking)
2	20-46 MPa	22	35 (5 l/min)

	Port size - Gewinde		Description/Bezeichnung
	V2, C2	T, Pil, M	
04	G 3/4"	G 1/4"	VMT-33-SX-04-1
46	1 1/16-12 UN-2B	9/16-18 UNF-2B	VMT-33-SX-46-1
94	3/4" JIS	1/4" JIS	VMT-33-SX-94-1

VMT-33-F12-1

TECHNICAL DATA TECHNISCHE ANGABEN

Max operating pressure Maximaler Betriebsdruck	42 MPa 5937 psi
Max flow Volumenstrom	150 l/min 40 gpm
Temperature range Betriebstemperatur	-20°/100°C other temperature ranges on request Weitere Temperaturbereiche auf Anfrage
Filtration Filtergrad	20µ
Weight Gewicht	6 kg
Material	Zincoated steel Verzinkter Stahl

This valve, controlled by remote pilot pressure, is especially studied for direct mounting on boom cylinders of hydraulic excavators, and for use in load holding and lowering control systems designed to comply with ISO Standard 8643 (hose burst protection).

Note: The tank port must be connected to a "low pressure tank line" (to the joystick tank line, or to the tank directly).

Dieses Ventil, das durch Fernsteuerungsdruck kontrolliert wird, wurde speziell für die Montage auf Auslegerzylinder von Hydraulikbaggern zur Anwendung in Lasthalte- und Lastabsenkungskontrolle konzipiert (entsprechend ISO Standard 8643, Rohrleitungsbruchsicherung).

Anmerkung: Der Anschluß „T“ muß an eine „Niederdrucktankleitung“ (an die Joystick-Tankleitung oder direkt an den Tank) angeschlossen werden.

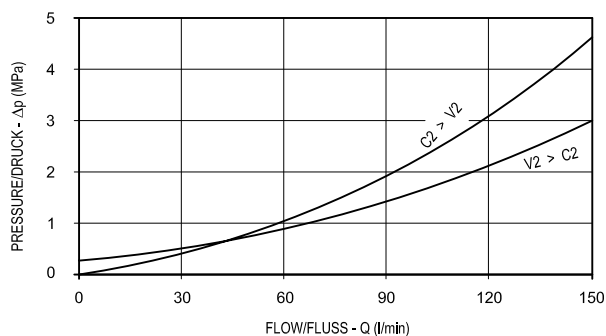

CYLINDER PORT C2 ZYLINDER ANSCHLUSS

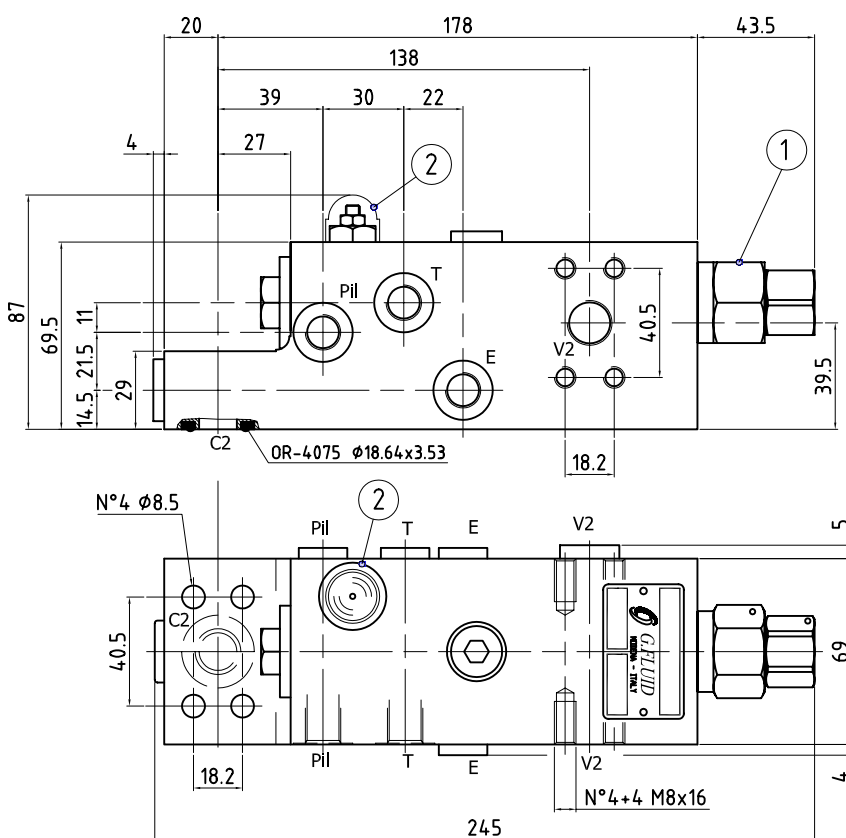
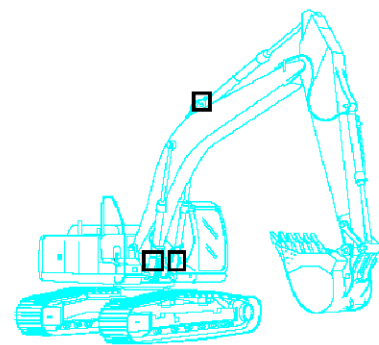
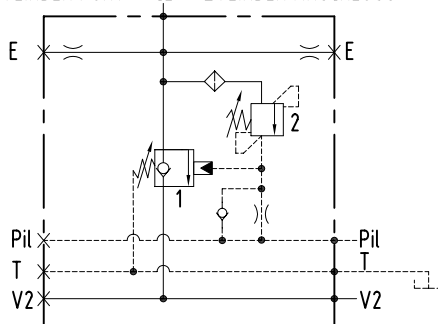

ORDERING INSTRUCTIONS - BESTELLANLEITUNG

702520 0 001

Valve Ventil	Spring pressure range Feder-Einstellbereich	Pressure increase MPa/turn Drucksteigerung MPa je Schraubendrehung	Standard setting MPa Standardeinstellung MPa	Port size - Gewinde		Description/Bezeichnung
				V2, C2	E, T, Pil	
13	1	0.3-1.5 MPa	0.49	0.75 (cracking)		23 1/2" SAE 6000 G 1/4" VMT-33-F12-1
	2	20-46 MPa	22	35 (5 l/min)		

VMT-33-F34-__-1

TECHNICAL DATA TECHNISCHE ANGABEN

Max operating pressure Maximaler Betriebsdruck	42 MPa 5937 psi
Max flow Volumenstrom	250 l/min 66 gpm
Temperature range Betriebstemperatur	-20°/100°C other temperature ranges on request Weitere Temperaturbereiche auf Anfrage
Filtration Filtergrad	20µ
Weight Gewicht	7 kg
Material Material	Zincoated steel Verzinkter Stahl

This valve, controlled by remote pilot pressure, is especially studied for direct mounting on boom cylinders of hydraulic excavators, and for use in load holding and lowering control systems designed to comply with ISO Standard 8643 (hose burst protection).

Note: The tank port must be connected to a "low pressure tank line" (to the joystick tank line, or to the tank directly).

Dieses Ventil, das durch Fernsteuerungsdruck kontrolliert wird, wurde speziell für die Montage auf Auslegerzylinder von Hydraulikbaggern zur Anwendung in Lasthalte- und Lastabsenkungskontrolle konzipiert (entsprechend ISO Standard 8643, Rohrleitungsbruchsicherung).

Anmerkung: Der Anschluß „T“ muß an eine „Niederdrucktankleitung“ (an die Joystick-Tankleitung oder direkt an den Tank) angeschlossen werden.

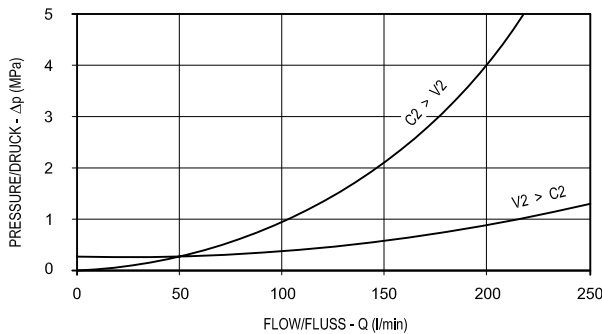

CYLINDER PORT C2 ZYLINDER ANSCHLUSS

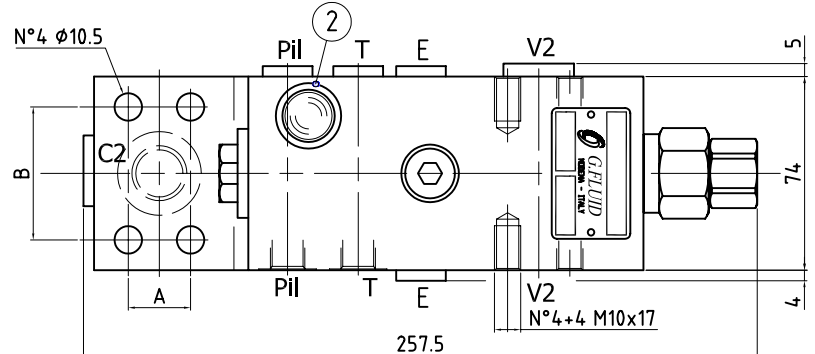
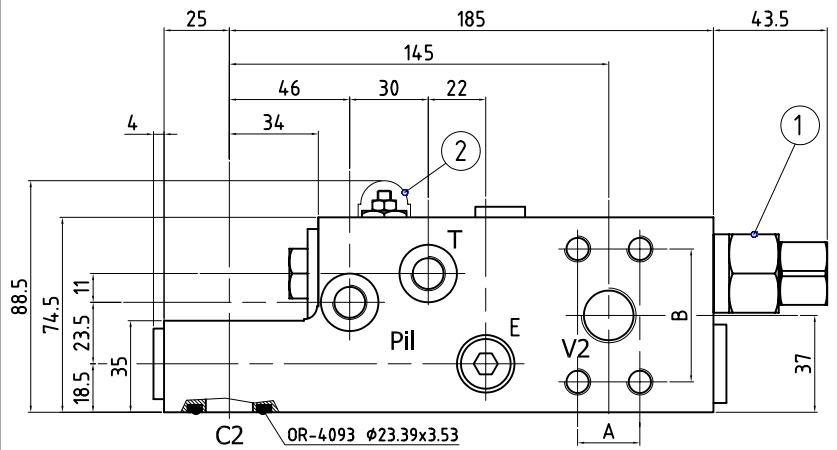
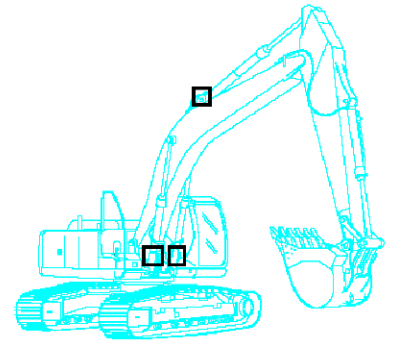
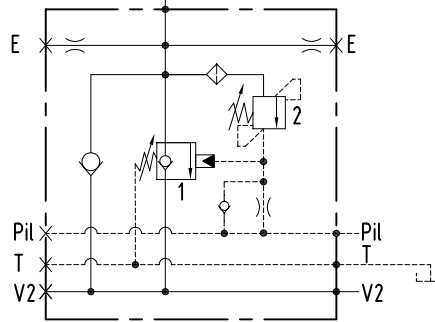

	3/4" SAE 3000	3/4" SAE 6000
A	22.2	23.8
B	47.6	50.8

ORDERING INSTRUCTIONS - BESTELLANLEITUNG

702620 0 001

Valve Ventil	Spring pressure range Feder-Einstellbereich	Pressure increase MPa/turn Drucksteigerung MPa je Schraubendrehung	Standard setting MPa Standardeinstellung MPa	Port size - Gewinde		Description/Bezeichnung
				V2, C2	E, T, Pil	
13	1	0.3-1.5 MPa	0.49	0.75 (cracking)	G 1/4"	VMT-33-F34-14-1
	2	20-46 MPa	22	35 (5 l/min)		VMT-33-F34-24-1
14				3/4" SAE 3000	G 1/4"	VMT-33-F34-14-1
24				3/4" SAE 6000		VMT-33-F34-24-1

VMT-33-F34-027-1

TECHNICAL DATA TECHNISCHE ANGABEN

Max operating pressure Maximaler Betriebsdruck	42 MPa 5937 psi
Max flow Volumenstrom	250 l/min 66 gpm
Temperature range Betriebstemperatur	-20°/100°C other temperature ranges on request Weitere Temperaturbereiche auf Anfrage
Filtration Filtergrad	20µ
Weight Gewicht	7 kg
Material Material	Zincoated steel Verzinkter Stahl

This valve, controlled by remote pilot pressure, is especially studied for direct mounting on boom cylinders of hydraulic excavators, and for use in load holding and lowering control systems designed to comply with ISO Standard 8643 (hose burst protection).

Note: The tank port must be connected to a "low pressure tank line" (to the joystick tank line, or to the tank directly).

Dieses Ventil, das durch Fernsteuerungsdruck kontrolliert wird, wurde speziell für die Montage auf Auslegerzylinder von Hydraulikbaggern zur Anwendung in Lasthalte- und Lastabsenkungskontrolle konzipiert (entsprechend ISO Standard 8643, Rohrleitungsbruchsicherung).

Anmerkung: Der Anschluß „T“ muß an eine „Niederdrucktankleitung“ (an die Joystick-Tankleitung oder direkt an den Tank) angeschlossen werden.

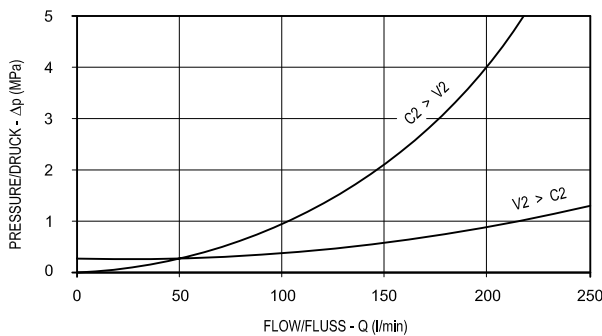

CYLINDER PORT C2 ZYLINDER ANSCHLUSS

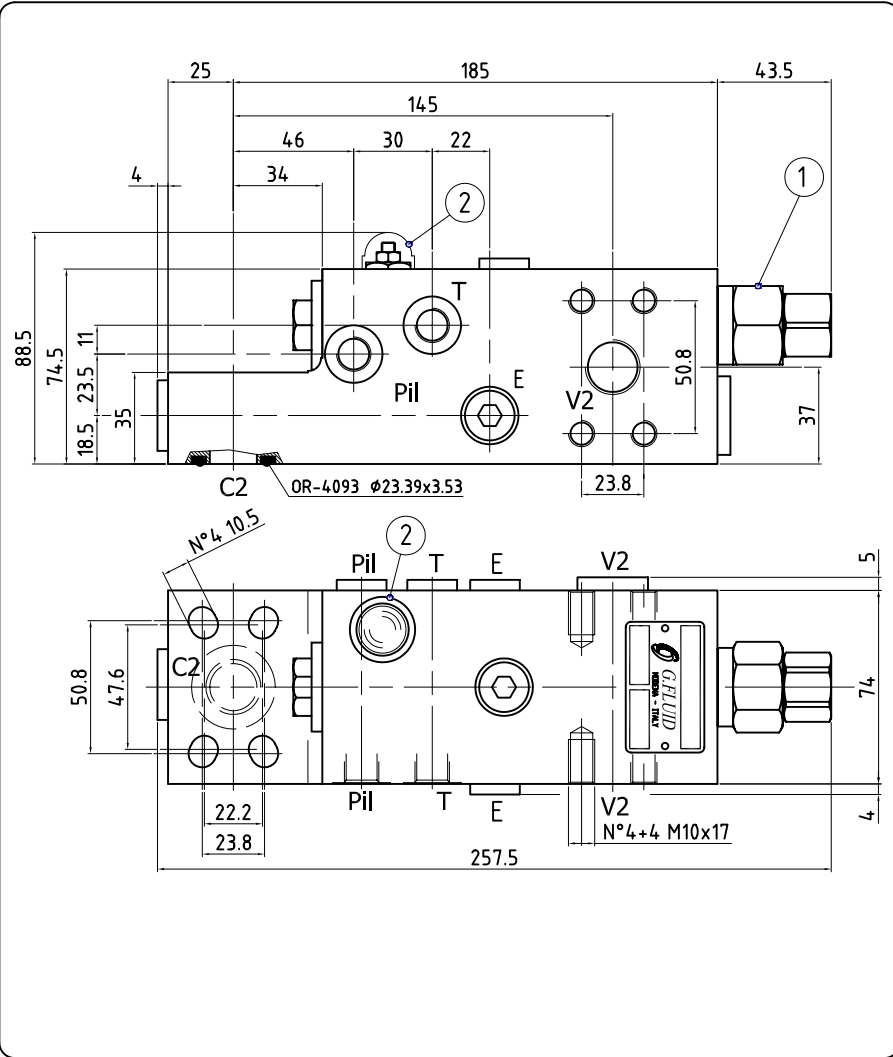
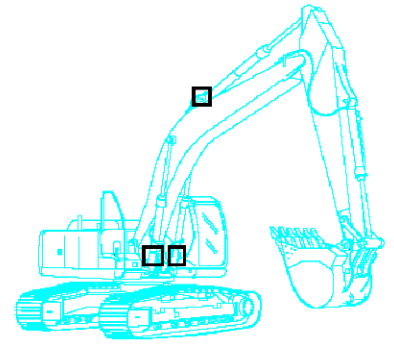
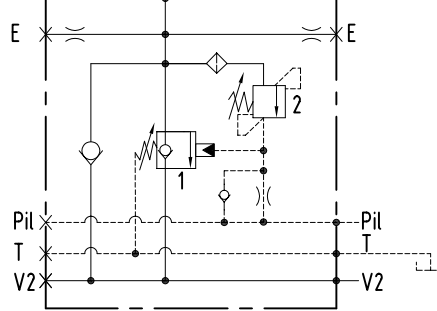

ORDERING INSTRUCTIONS - BESTELLANLEITUNG

702720 0 001

Valve Ventil	Spring pressure range Feder-Einstellbereich	Pressure increase MPa/turn Drucksteigerung MPa je Schraubendrehung	Standard setting MPa Standardeinstellung MPa	Port size - Gewinde			Description/Bezeichnung
				V2	C2	E, T, PIL	
13	1	0.3-1.5 MPa	0.49	0.75 (cracking)			VMT-33-F34-027-1
	2	20-46 MPa	22	35 (5 l/min)			
24				3/4" SAE 6000	3/4" SAE 3000	G 1/4"	VMT-33-F34-027-1
					3/4" SAE 6000		

VMT-33-F34-028-1

TECHNICAL DATA TECHNISCHE ANGABEN

Max operating pressure Maximaler Betriebsdruck	42 MPa 5937 psi
Max flow Volumenstrom	250 l/min 66 gpm
Temperature range Betriebstemperatur	-20°/100°C other temperature ranges on request Weitere Temperaturbereiche auf Anfrage
Filtration Filtergrad	20µ
Weigth Gewicht	7 kg
Material Material	Zincoated steel Verzinkter Stahl

This valve, controlled by remote pilot pressure, is especially studied for direct mounting on boom cylinders of hydraulic excavators, and for use in load holding and lowering control systems designed to comply with ISO Standard 8643 (hose burst protection).

Note: The tank port must be connected to a "low pressure tank line" (to the joystick tank line, or to the tank directly).

Dieses Ventil, das durch Fernsteuerungsdruck kontrolliert wird, wurde speziell für die Montage auf Auslegerzylinder von Hydraulikbaggern zur Anwendung in Lasthalte- und Lastabsenkungskontrolle konzipiert (entsprechend ISO Standard 8643, Rohrleitungsbruchsicherung).

Anmerkung: Der Anschluß „T“ muß an eine „Niederdrucktankleitung“ (an die Joystick-Tankleitung oder direkt an den Tank) angeschlossen werden.

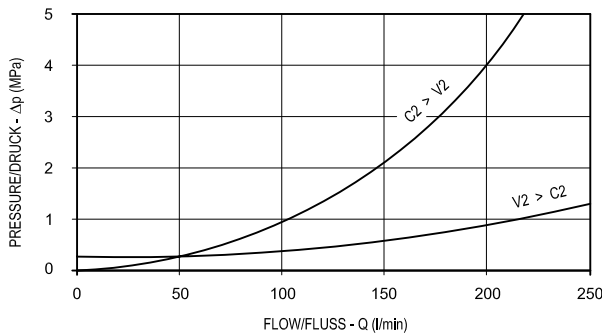

CYLINDER PORT C2 ZYLINDER ANSCHLUSS

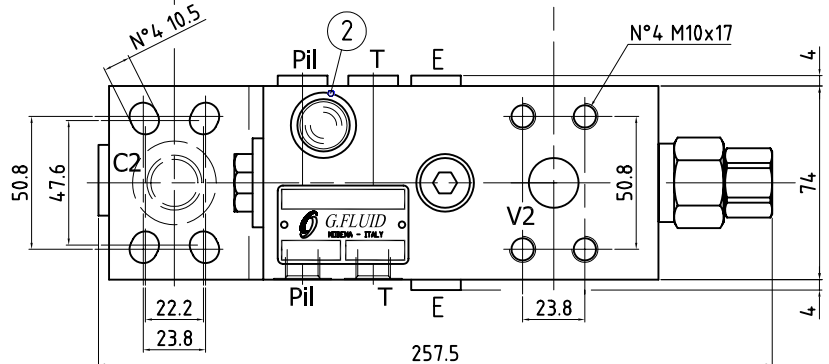
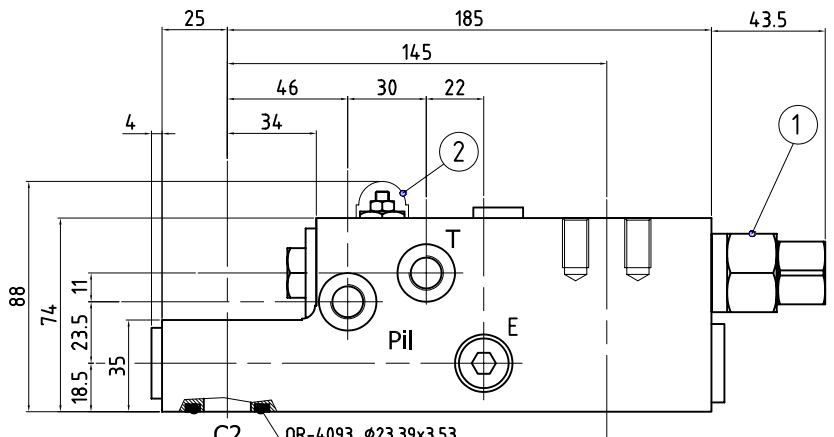
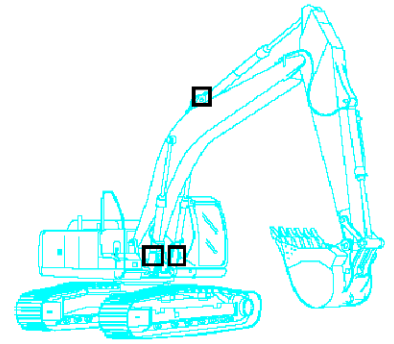
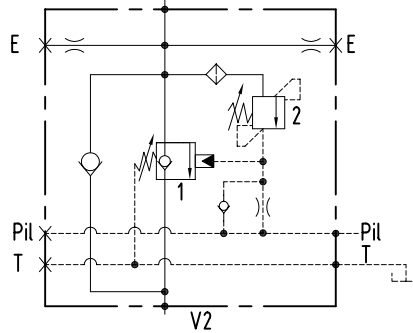

ORDERING INSTRUCTIONS - BESTELLANLEITUNG

702820 0 001

				Port size - Gewinde			
				V2	C2	E, T, PIL	Description/Bezeichnung
13	1	0.3-1.5 MPa	0.49				
	2	20-46 MPa	22				
24				3/4"	3/4" SAE 3000	G 1/4"	VMT-33-F34-028-1
				SAE 6000	3/4" SAE 6000		

VMT-42-F__-1

TECHNICAL DATA TECHNISCHE ANGABEN

Max operating pressure Maximaler Betriebsdruck	42 MPa 5937 psi
Max flow Volumenstrom	400 l/min 106 gpm
Temperature range Betriebstemperatur	-20°/100°C other temperature ranges on request Weitere Temperaturbereiche auf Anfrage
Filtration Filtergrad	20µ
Weight Gewicht	12 kg
Material Material	Zincoated steel Verzinkter Stahl

This valve, controlled by remote pilot pressure, is especially studied for direct mounting on boom cylinders of hydraulic excavators, and for use in load holding and lowering control systems designed to comply with ISO Standard 8643 (hose burst protection).

Note: The tank port must be connected to a "low pressure tank line" (to the joystick tank line, or to the tank directly).

Dieses Ventil, das durch Fernsteuerungsdruck kontrolliert wird, wurde speziell für die Montage auf Auslegerzylinder von Hydraulikbaggern zur Anwendung in Lasthalte- und Lastabsenkungskontrolle konzipiert (entsprechend ISO Standard 8643, Rohrleitungsbruchsicherung).

Anmerkung: Der Anschluß „T“ muß an eine „Niederdrucktankleitung“ (an die Joystick-Tankleitung oder direkt an den Tank) angeschlossen werden.

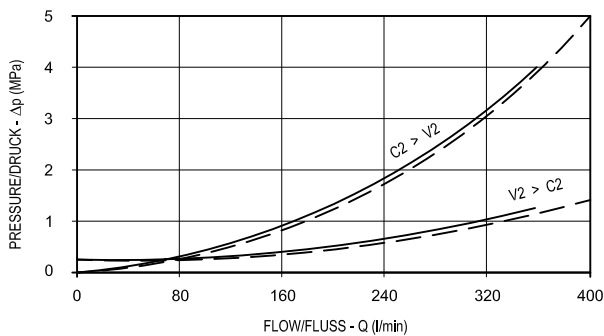

— V2, C2 = 3/4" SAE 6000
- - - V2, C2 = 1" SAE 6000

CYLINDER PORT C2 ZYLINDER ANSCHLUSS

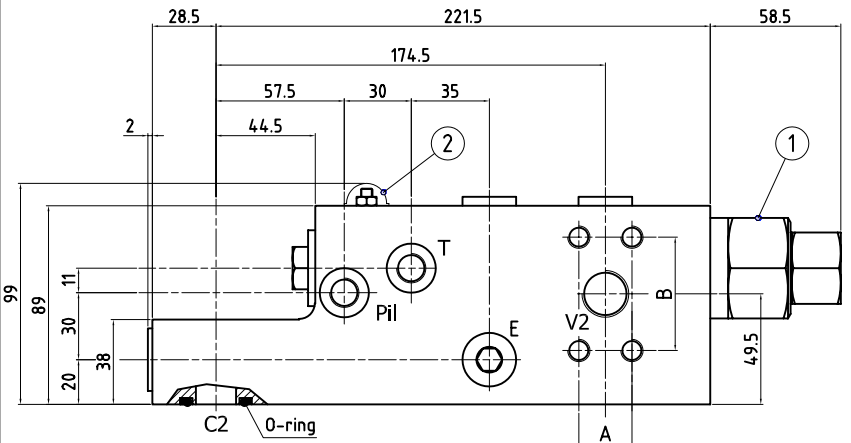
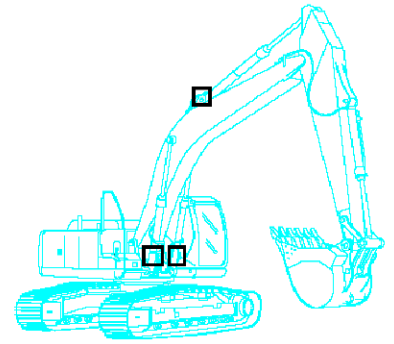
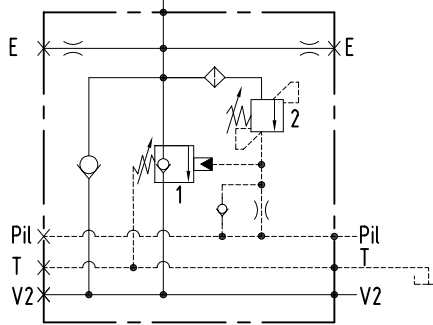

N°4 holes / Bohrungen ØF

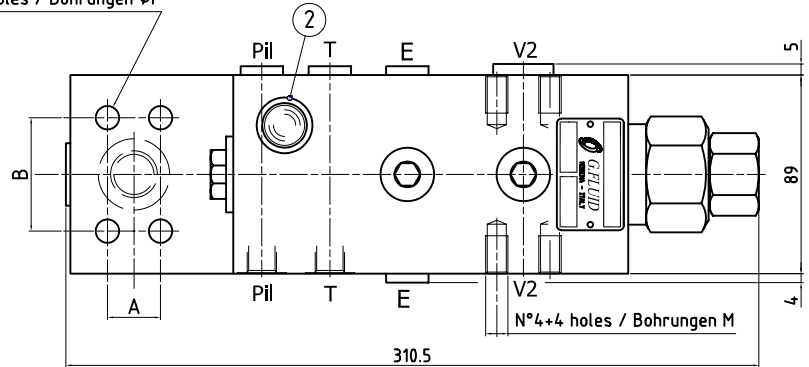

	A	B	F	M	0-ring
3/4" SAE 6000	23.8	50.8	Ø10.5	M10x17	23.39x3.53
1" SAE 6000	27.8	57.2	Ø12.5	M12x20	32.92x3.53

ORDERING INSTRUCTIONS - BESTELLANLEITUNG

703020 0 001

Valve Ventil	Spring pressure range Feder-Einstellbereich	Pressure increase MPa/turn Drucksteigerung MPa je Schraubendrehung	Standard setting MPa Standardeinstellung MPa	Port size - Gewinde		
				V2, C2	E, T, PIL Description/Bezeichnung	
13	1	0.3-1.5 MPa	0.49	0.75 (cracking)	24 3/4" SAE 6000	G 1/4" VMT-42-F34-1
	2	20-46 MPa	22	35 (5 l/min)	25 1" SAE 6000	VMT-42-F1-1

VMT-42-F1-033-1

TECHNICAL DATA TECHNISCHE ANGABEN

Max operating pressure Maximaler Betriebsdruck	42 MPa 5937 psi
Max flow Volumenstrom	400 l/min 106 gpm
Temperature range Betriebstemperatur	-20°/100°C other temperature ranges on request Weitere Temperaturbereiche auf Anfrage
Filtration Filtergrad	20µ
Weight Gewicht	12.5 kg
Material Material	Zincoated steel Verzinkter Stahl

This valve, controlled by remote pilot pressure, is especially studied for direct mounting on boom cylinders of hydraulic excavators, and for use in load holding and lowering control systems designed to comply with ISO Standard 8643 (hose burst protection).

Note: The tank port must be connected to a "low pressure tank line" (to the joystick tank line, or to the tank directly).

Dieses Ventil, das durch Fernsteuerungsdruck kontrolliert wird, wurde speziell für die Montage auf Auslegerzylinder von Hydraulikbaggern zur Anwendung in Lasthalte- und Lastabsenkungskontrolle konzipiert (entsprechend ISO Standard 8643, Rohrleitungsbruchsicherung).

Anmerkung: Der Anschluß „T“ muß an eine „Niederdrucktankleitung“ (an die Joystick-Tankleitung oder direkt an den Tank) angeschlossen werden.

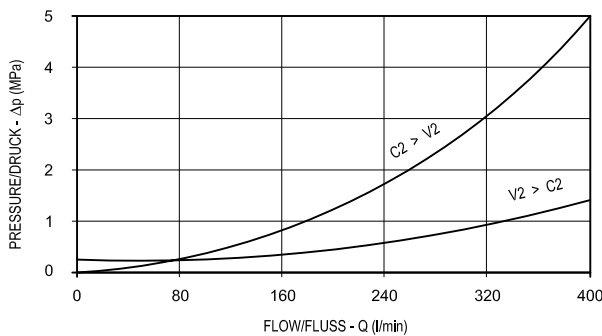

CYLINDER PORT C2 ZYLINDER ANSCHLUSS

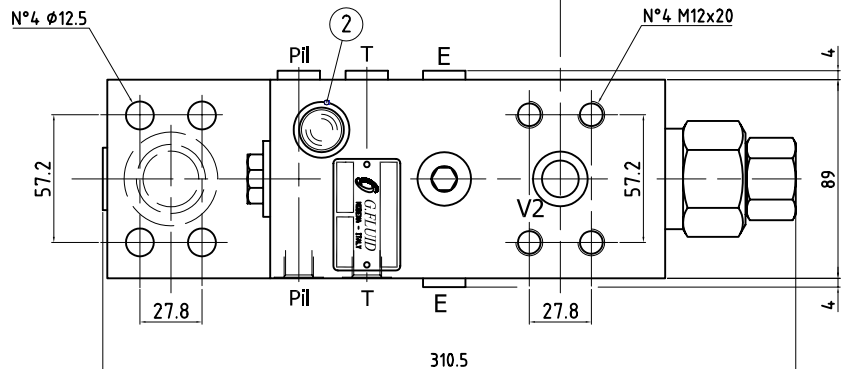
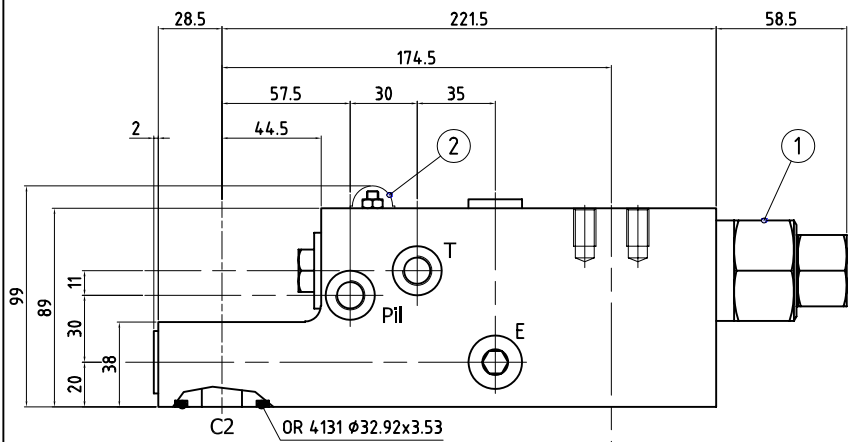
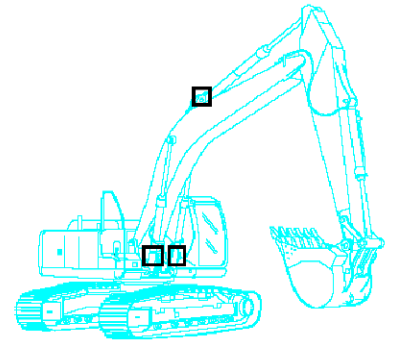
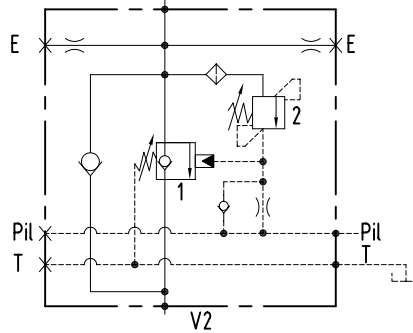

ORDERING INSTRUCTIONS - BESTELLANLEITUNG

703320 0 001

Valve Ventil	Spring pressure range Feder-Einstellbereich	Pressure increase MPa/turn Drucksteigerung MPa je Schraubendrehung	Standard setting MPa Standardeinstellung MPa	Port size - Gewinde		
				V2, C2	E, T, PIL	Description/Bezeichnung
13	1	0.3-1.5 MPa	0.49	0.75 (cracking)		
	2	20-46 MPa	22	35 (5 l/min)		
				25	1" SAE 6000	G 1/4" VMT-42-F1-033-1

VMT-42-F1-034-1

TECHNICAL DATA TECHNISCHE ANGABEN

Max operating pressure Maximaler Betriebsdruck	42 MPa 5937 psi
Max flow Volumenstrom	400 l/min 106 gpm
Temperature range Betriebstemperatur	-20°/100°C other temperature ranges on request Weitere Temperaturbereiche auf Anfrage
Filtration Filtergrad	20µ
Weight Gewicht	12.5 kg
Material Material	Zincoated steel Verzinkter Stahl

This valve, controlled by remote pilot pressure, is especially studied for direct mounting on boom cylinders of hydraulic excavators, and for use in load holding and lowering control systems designed to comply with ISO Standard 8643 (hose burst protection).

Note: The tank port must be connected to a "low pressure tank line" (to the joystick tank line, or to the tank directly).

Dieses Ventil, das durch Fernsteuerungsdruck kontrolliert wird, wurde speziell für die Montage auf Auslegerzylinder von Hydraulikbaggern zur Anwendung in Lasthalte- und Lastabsenkungskontrolle konzipiert (entsprechend ISO Standard 8643, Rohrleitungsbruchsicherung).

Anmerkung: Der Anschluß „T“ muß an eine „Niederdrucktankleitung“ (an die Joystick-Tankleitung oder direkt an den Tank) angeschlossen werden.

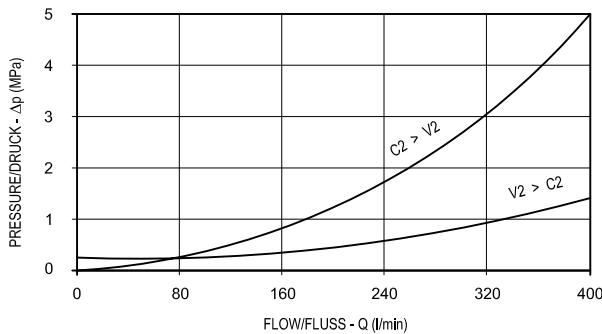

V2, C2 = 1" SAE 6000

CYLINDER PORT C2 ZYLINDER ANSCHLUSS

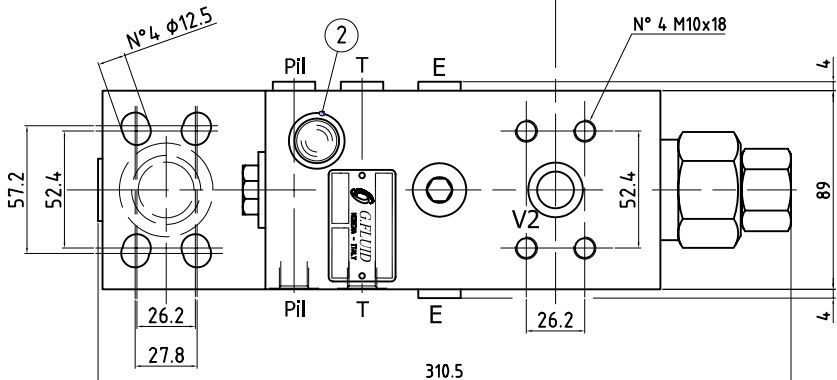
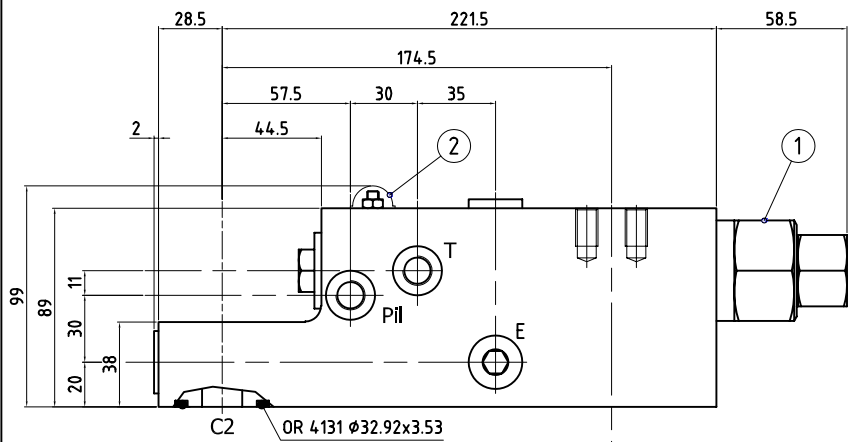
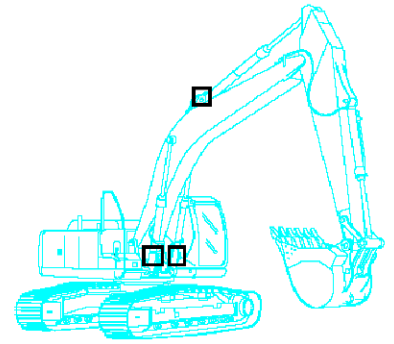
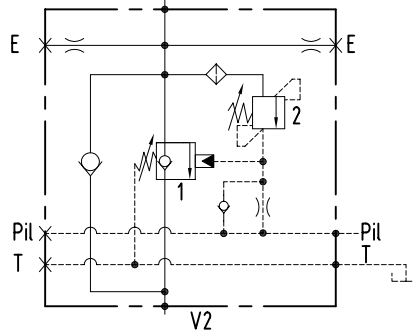

ORDERING INSTRUCTIONS - BESTELLEANLEITUNG

703420 0 001

Valve Ventil	Spring pressure range Feder-Einstellbereich	Pressure increase MPa/turn Drucksteigerung MPa je Schraubendrehung	Standard setting MPa Standardeinstellung MPa	Port size - Gewinde		Description/Bezeichnung
				V2	C2 E, T, PIL	
13	1	0.3-1.5 MPa	0.49	0.75 (cracking)		VMT-42-F1-034-1
	2	20-46 MPa	22	35 (5 l/min)		
15					G 1/4"	VMT-42-F1-034-1
	1"	1" SAE 3000				

VMT-42-3F1-1

TECHNICAL DATA TECHNISCHE ANGABEN

Max operating pressure Maximaler Betriebsdruck	42 MPa 5937 psi
Max flow Volumenstrom	400 l/min 106 gpm
Temperature range Betriebstemperatur	-20°/100°C other temperature ranges on request Weitere Temperaturbereiche auf Anfrage
Filtration Filtergrad	20µ
Weight Gewicht	16.0 kg
Material Material	Zincoated steel Verzinkter Stahl

This valve, controlled by remote pilot pressure, is especially studied for direct mounting on boom cylinders of hydraulic excavators, and for use in load holding and lowering control systems designed to comply with ISO Standard 8643 (hose burst protection).

Note: The tank port must be connected to a "low pressure tank line" (to the joystick tank line, or to the tank directly).

Dieses Ventil, das durch Fernsteuerungsdruck kontrolliert wird, wurde speziell für die Montage auf Auslegerzylinder von Hydraulikbaggern zur Anwendung in Lasthalte- und Lastabsenkungskontrolle konzipiert (entsprechend ISO Standard 8643, Rohrleitungsbruchsicherung).

Anmerkung: Der Anschluß „T“ muß an eine „Niederdrucktankleitung“ (an die Joystick-Tankleitung oder direkt an den Tank) angeschlossen werden.

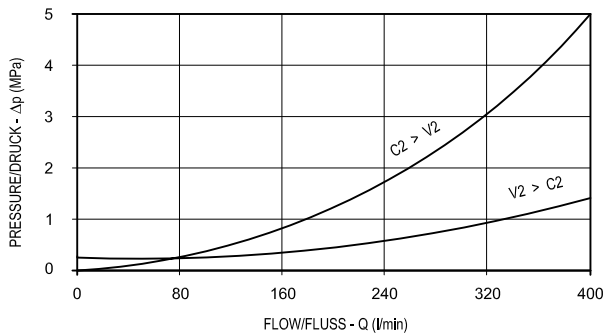

V2, C2 = 1" SAE 300
 1" SAE 6000

CYLINDER PORT C2 ZYLINDER ANSCHLUSS

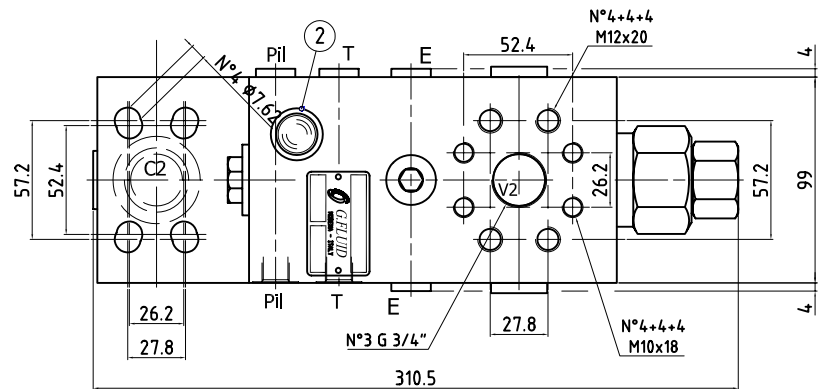
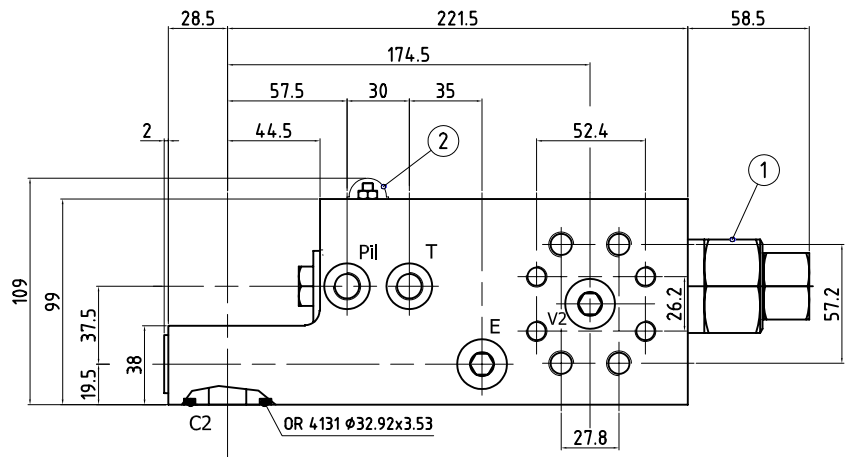
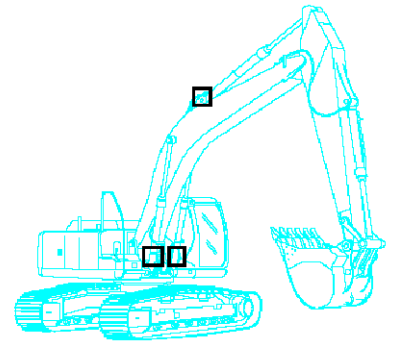
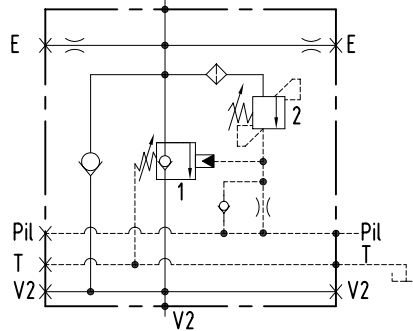

ORDERING INSTRUCTIONS - BESTELLANLEITUNG

703520 0 001

Valve Ventil	Spring pressure range Feder-Einstellbereich	Pressure increase MPa/turn Drucksteigerung MPa je Schraubendrehung	Standard setting MPa Standardeinstellung MPa	Port size - Gewinde				
				V2	C2	E, T, PIL	Description/Bezeichnung	
13	1	0.3-1.5 MPa	0.49	0.75 (cracking)				VMT-42-3F1-1
	2	20-46 MPa	22	35 (5 l/min)				
25					1" SAE 3000 1" SAE 6000	1" SAE 3000 1" SAE 6000	G 1/4"	VMT-42-3F1-1

VMT-42-F114-1

TECHNICAL DATA TECHNISCHE ANGABEN

Max operating pressure Maximaler Betriebsdruck	42 MPa 5937 psi
Max flow Volumenstrom	500 l/min 132 gpm
Temperature range Betriebstemperatur	-20°/100°C other temperature ranges on request Weitere Temperaturbereiche auf Anfrage
Filtration Filtergrad	20µ
Weight Gewicht	15 kg
Material Material	Zincoated steel Verzinkter Stahl

This valve, controlled by remote pilot pressure, is especially studied for direct mounting on boom cylinders of hydraulic excavators, and for use in load holding and lowering control systems designed to comply with ISO Standard 8643 (hose burst protection).

Note: The tank port must be connected to a "low pressure tank line" (to the joystick tank line, or to the tank directly).

Dieses Ventil, das durch Fernsteuerungsdruck kontrolliert wird, wurde speziell für die Montage auf Auslegerzylinder von Hydraulikbaggern zur Anwendung in Lasthalte- und Lastabsenkungskontrolle konzipiert (entsprechend ISO Standard 8643, Rohrleitungsbruchsicherung).

Anmerkung: Der Anschluß „T“ muß an eine „Niederdrucktankleitung“ (an die Joystick-Tankleitung oder direkt an den Tank) angeschlossen werden.

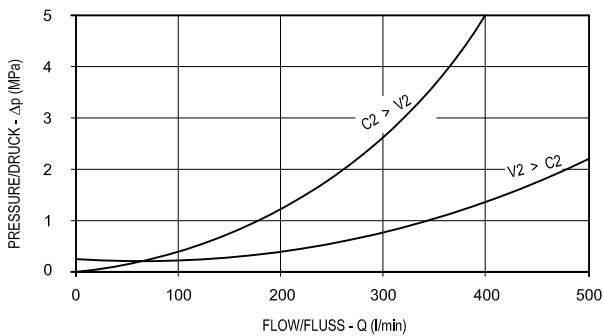

CYLINDER PORT C2 ZYLINDER ANSCHLUSS

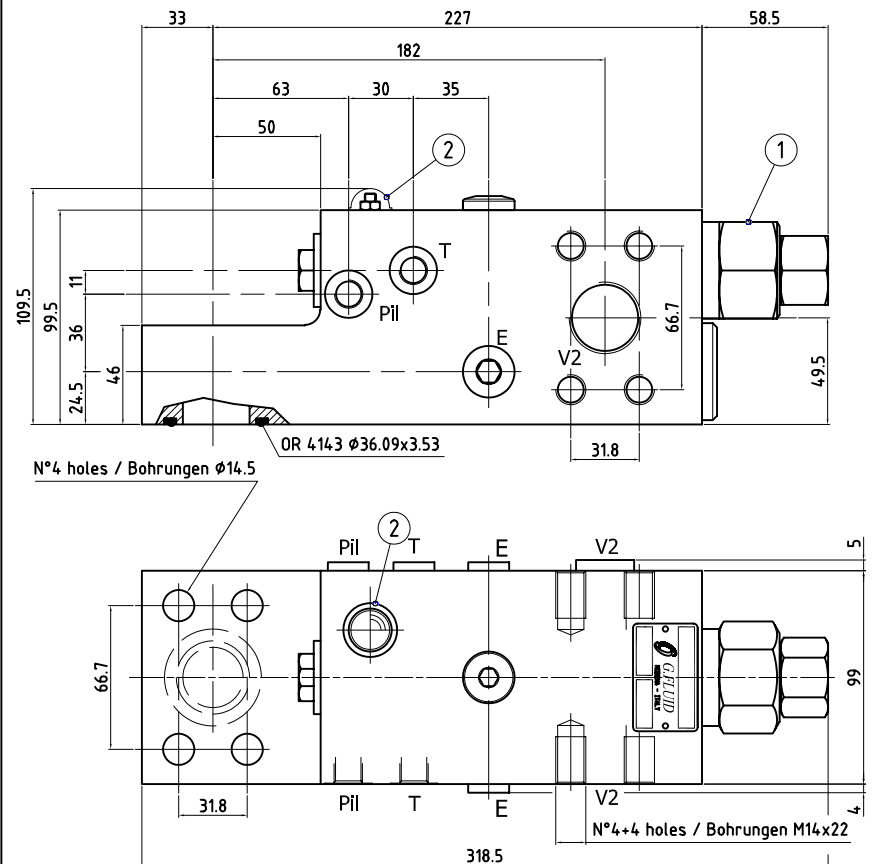
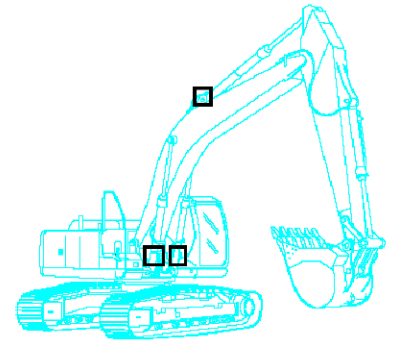
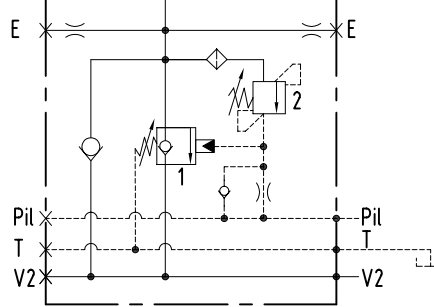

ORDERING INSTRUCTIONS - BESTELLANLEITUNG

704020 0 001

Valve Ventil	Spring pressure range Feder-Einstellbereich	Pressure increase MPa/turn Drucksteigerung MPa je Schraubendrehung	Standard setting MPa Standardeinstellung MPa	Port size - Gewinde V2, C2	E, T, PIL Description/Bezeichnung
13	1	0.3-1.5 MPa	0.49	0.75 (cracking)	26 1" 1/4 SAE 6000 G 1/4" VMT-42-F114-1
	2	20-46 MPa	22	35 (5 l/min)	

VMT-42-F114-043-1

TECHNICAL DATA TECHNISCHE ANGABEN

Max operating pressure Maximaler Betriebsdruck	42 MPa 5937 psi
Max flow Volumenstrom	500 l/min 132 gpm
Temperature range Betriebstemperatur	-20°/100°C other temperature ranges on request Weitere Temperaturbereiche auf Anfrage
Filtration Filtergrad	20µ
Weight Gewicht	15 kg
Material Material	Zincoated steel Verzinkter Stahl

This valve, controlled by remote pilot pressure, is especially studied for direct mounting on boom cylinders of hydraulic excavators, and for use in load holding and lowering control systems designed to comply with ISO Standard 8643 (hose burst protection).

Note: The tank port must be connected to a "low pressure tank line" (to the joystick tank line, or to the tank directly).

Dieses Ventil, das durch Fernsteuerungsdruck kontrolliert wird, wurde speziell für die Montage auf Auslegerzylinder von Hydraulikbaggern zur Anwendung in Lasthalte- und Lastabsenkungskontrolle konzipiert (entsprechend ISO Standard 8643, Rohrleitungsbruchsicherung).

Anmerkung: Der Anschluß „T“ muß an eine „Niederdrucktankleitung“ (an die Joystick-Tankleitung oder direkt an den Tank) angeschlossen werden.

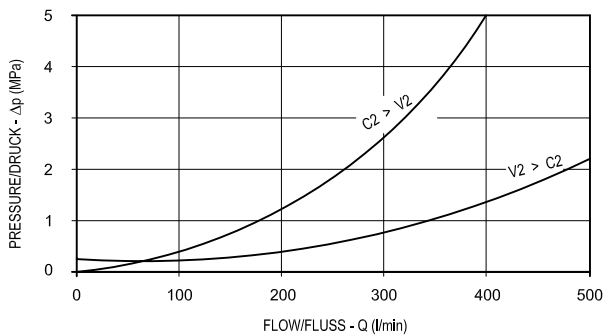

CYLINDER PORT C2 ZYLINDER ANSCHLUSS

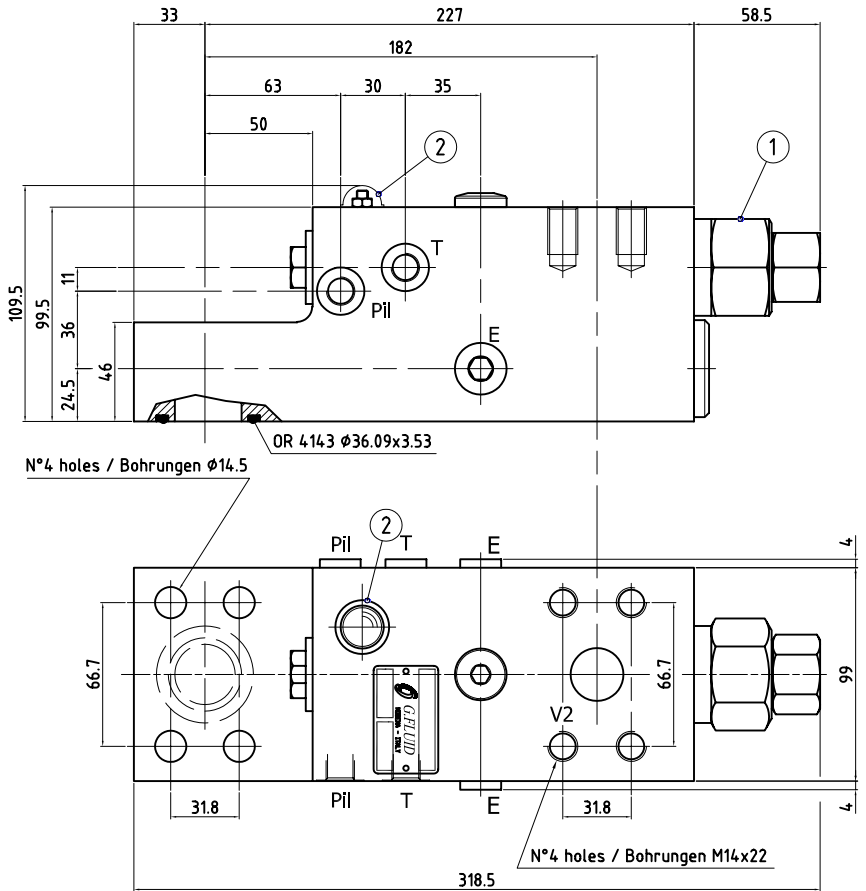
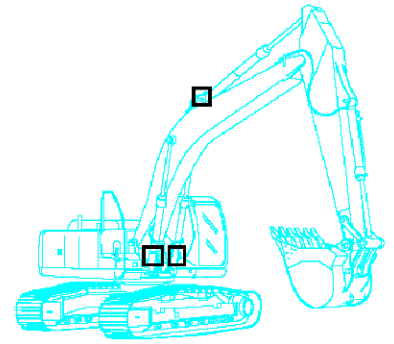
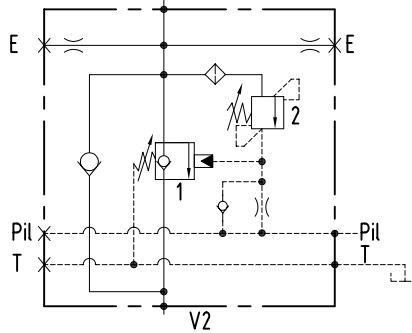

ORDERING INSTRUCTIONS - BESTELLEANLEITUNG

704320 0 001

Valve Ventil	Spring pressure range Feder-Einstellbereich	Pressure increase MPa/turn Drucksteigerung MPa je Schraubendrehung	Standard setting MPa Standardeinstellung MPa	Port size - Gewinde	
				V2, C2	E, T, PIL Description/Bezeichnung
13	1	0.3-1.5 MPa	0.49	0.75 (cracking)	26 1" 1/4 SAE 6000 G 1/4" VMT-42-F114-043-1
	2	20-46 MPa	22	35 (5 l/min)	

VMT-242-F1-1

TECHNICAL DATA TECHNISCHE ANGABEN

Max operating pressure Maximaler Betriebsdruck	42 MPa 5937 psi
Max flow Volumenstrom	500 l/min 132 gpm
Temperature range Betriebstemperatur	-20°/100°C other temperature ranges on request Weitere Temperaturbereiche auf Anfrage
Filtration Filtergrad	20µ
Weight Gewicht	19.2 kg
Material Material	Zincoated steel Verzinkter Stahl

This valve, controlled by remote pilot pressure, is especially studied for direct mounting on boom cylinders of hydraulic excavators, and for use in load holding and lowering control systems designed to comply with ISO Standard 8643 (hose burst protection).

Note: The tank port must be connected to a "low pressure tank line" (to the joystick tank line, or to the tank directly).

Dieses Ventil, das durch Fernsteuerungsdruck kontrolliert wird, wurde speziell für die Montage auf Auslegerzylinder von Hydraulikbaggern zur Anwendung in Lasthalte- und Lastabsenkungskontrolle konzipiert (entsprechend ISO Standard 8643, Rohrleitungsbruchsicherung).

Anmerkung: Der Anschluß „T“ muß an eine „Niederdrucktankleitung“ (an die Joystick-Tankleitung oder direkt an den Tank) angeschlossen werden.

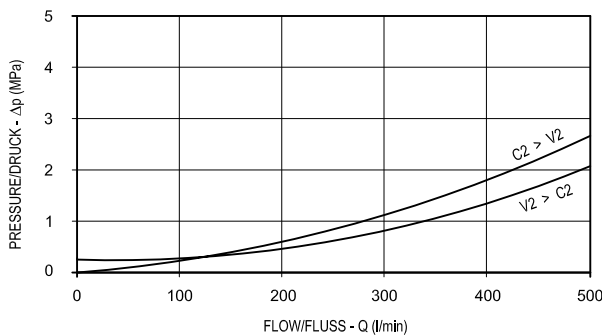

CYLINDER PORT C2 ZYLINDER ANSCHLUSS

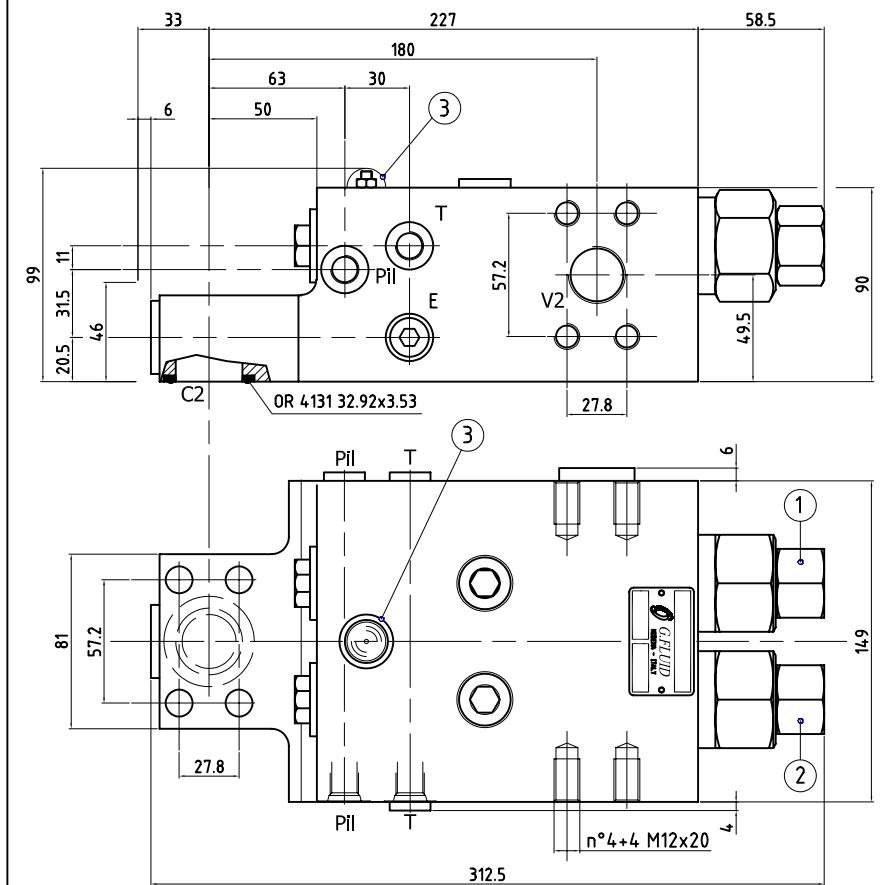
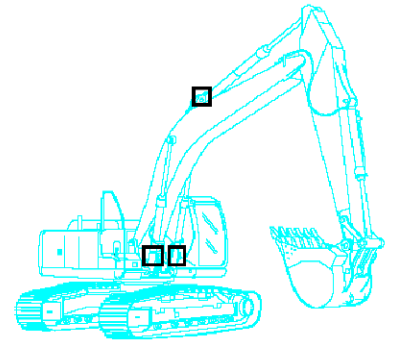
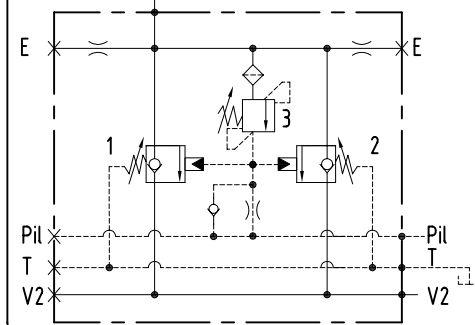

ORDERING INSTRUCTIONS - BESTELLANLEITUNG

705020 0 021

Valve Ventil	Spring pressure range Feder-Einstellbereich	Pressure increase MPa/turn Drucksteigerung MPa je Schraubendrehung	Standard setting MPa Standardeinstellung MPa	Port size - Gewinde		Description/Bezeichnung
13	1-2	0.3-1.5 MPa	0.49	0.75 (cracking)	V2, C2	E, T, PIL
	3	20-46 MPa	22	37 (5 l/min)	1" SAE 6000 3/4" BSPP	G 1/4" JIS B 2351
25						VMT-242-F1-1

VMT-242-F114-1

TECHNICAL DATA TECHNISCHE ANGABEN

Max operating pressure Maximaler Betriebsdruck	42 MPa 5937 psi
Max flow Volumenstrom	500 l/min 132 gpm
Temperature range Betriebstemperatur	-20°/100°C other temperature ranges on request Weitere Temperaturbereiche auf Anfrage
Filtration Filtergrad	20µ
Weight Gewicht	21.8 kg
Material Material	Zincoated steel Verzinkter Stahl

This valve, controlled by remote pilot pressure, is especially studied for direct mounting on boom cylinders of hydraulic excavators, and for use in load holding and lowering control systems designed to comply with ISO Standard 8643 (hose burst protection).

Note: The tank port must be connected to a "low pressure tank line" (to the joystick tank line, or to the tank directly).

Dieses Ventil, das durch Fernsteuerungsdruck kontrolliert wird, wurde speziell für die Montage auf Auslegerzylinder von Hydraulikbaggern zur Anwendung in Lasthalte- und Lastabsenkungskontrolle konzipiert (entsprechend ISO Standard 8643, Rohrleitungsbruchsicherung).

Anmerkung: Der Anschluß „T“ muß an eine „Niederdrucktankleitung“ (an die Joystick-Tankleitung oder direkt an den Tank) angeschlossen werden.

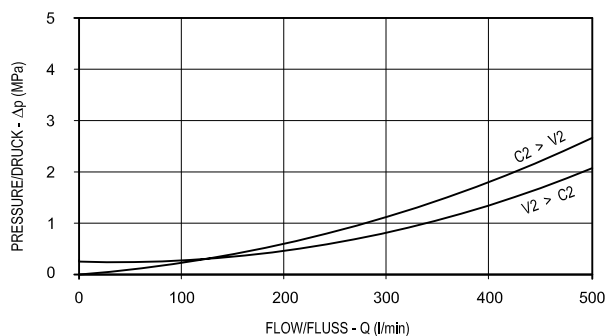

CYLINDER PORT C2 ZYLINDER ANSCHLUSS

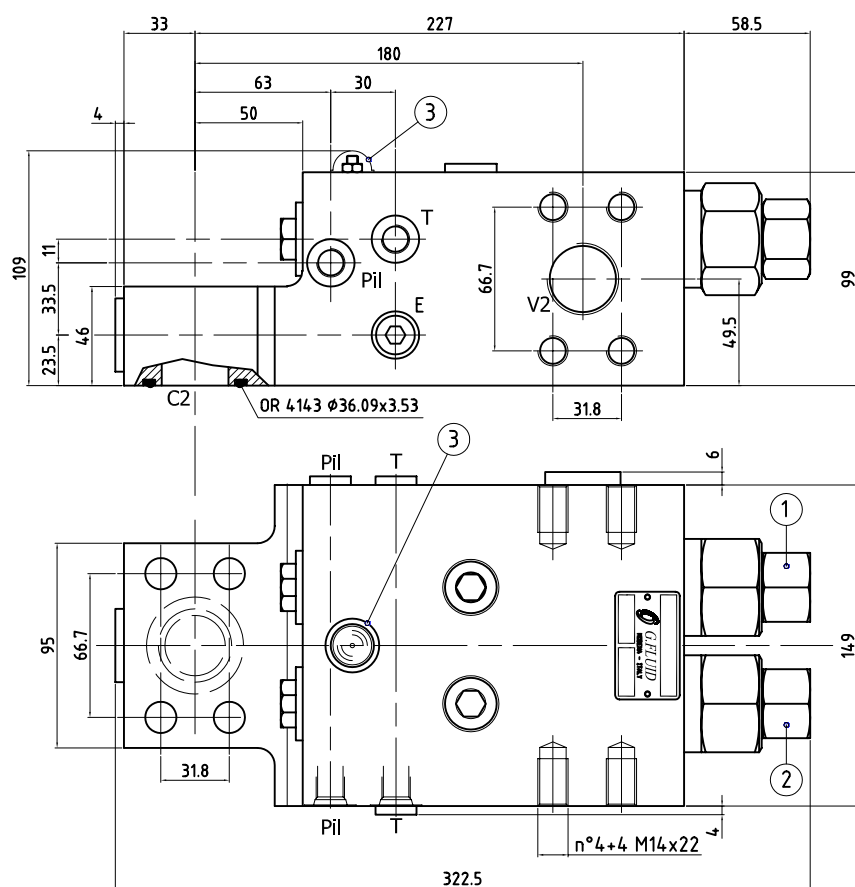
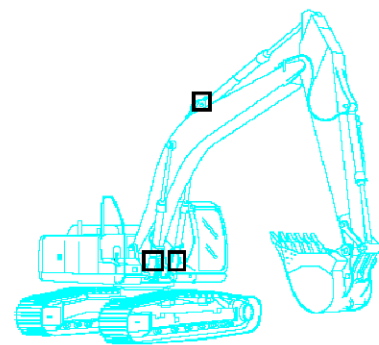
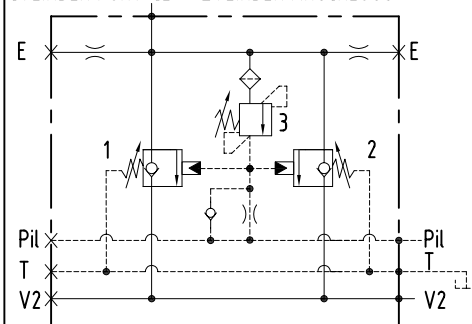

ORDERING INSTRUCTIONS - BESTELLANLEITUNG

705520 0 021

Valve Ventil	Spring pressure range Feder-Einstellbereich	Pressure increase MPa/turn Drucksteigerung MPa je Schraubendrehung	Standard setting MPa Standardeinstellung MPa	Port size - Gewinde		Description/Bezeichnung
				V2, C2	E, T, PIL	
13	1-2	0.3-1.5 MPa	0.49	0.75 (cracking)	1" 1/4 SAE 6000 1" BSPP	VMT-242-F114-1
	3	20-46 MPa	22	37 (5 l/min)		
26					G 1/4" JIS B 2351	

VMT-242-F112-1

TECHNICAL DATA TECHNISCHE ANGABEN

Max operating pressure Maximaler Betriebsdruck	55 MPa 7936 psi
Max flow Volumenstrom	700 l/min 172 gpm
Temperature range Betriebstemperatur	-20°/100°C other temperature ranges on request Weitere Temperaturbereiche auf Anfrage
Filtration Filtergrad	20µ
Weight Gewicht	26.6 kg
Material Material	Zincoated steel Verzinkter Stahl

This valve, controlled by remote pilot pressure, is especially studied for direct mounting on boom cylinders of hydraulic excavators, and for use in load holding and lowering control systems designed to comply with ISO Standard 8643 (hose burst protection).

Note: The tank port must be connected to a "low pressure tank line" (to the joystick tank line, or to the tank directly).

Dieses Ventil, das durch Fernsteuerungsdruck kontrolliert wird, wurde speziell für die Montage auf Auslegerzylinder von Hydraulikbaggern zur Anwendung in Lasthalte- und Lastabsenkungskontrolle konzipiert (entsprechend ISO Standard 8643, Rohrleitungsbruchsicherung).

Anmerkung: Der Anschluß „T“ muß an eine „Niederdrucktankleitung“ (an die Joystick-Tankleitung oder direkt an den Tank) angeschlossen werden.

CYLINDER PORT C2 ZYLINDER ANSCHLUSS

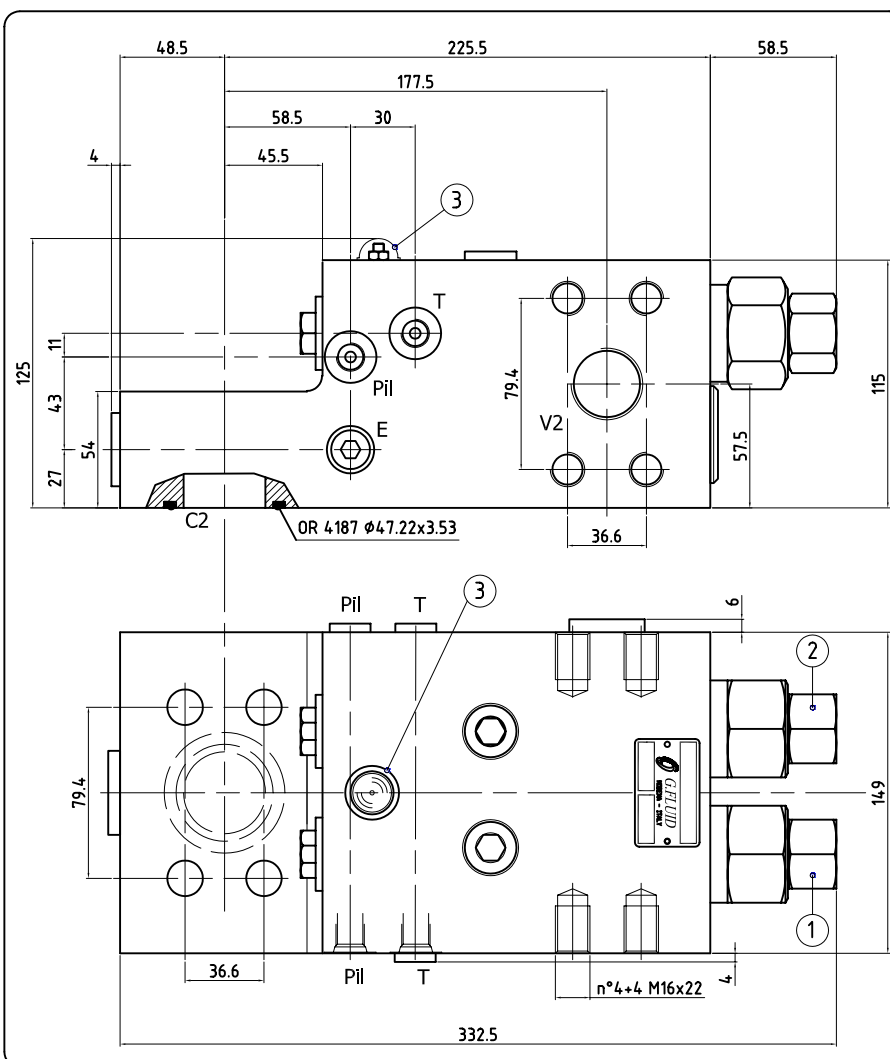
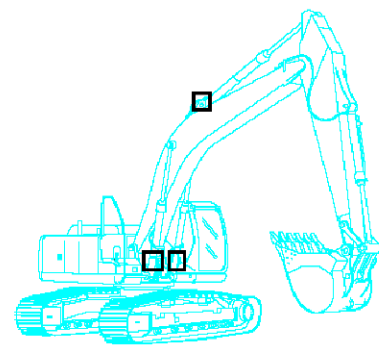
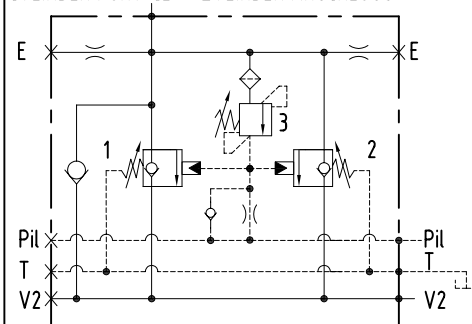

ORDERING INSTRUCTIONS - BESTELLANLEITUNG

706020 0 031

Valve Ventil	Spring pressure range Feder-Einstellbereich	Pressure increase MPa/turn Drucksteigerung MPa je Schraubendrehung	Standard setting MPa Standardeinstellung MPa	Port size - Gewinde	
				V2, C2	E, T, PIL Description/Bezeichnung
14	1	0.3-1.5 MPa	0.49	0.75 (cracking)	27 1" 1/2 SAE 6000 G 1/4" JIS B 2351 VMT-242-F112-1
	2	0.3-1.5 MPa	0.49	1.05 (cracking)	
	3	35-55 MPa	22	55 (5 l/min)	

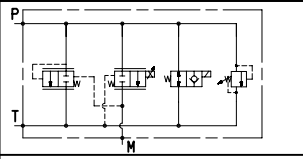
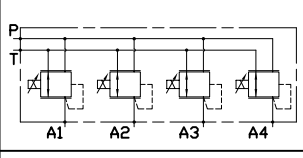
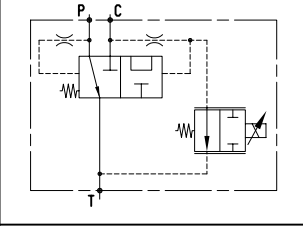
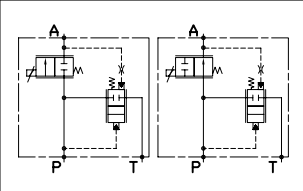
Scheme Schema	Description Bezeichnung	max flow max Durchfluß	max pressure max Arbeitsdruck	page Seite
	<i>GVP-RF-CP-VE-VS-12-CLS</i>	30 l/min 7.9 gpm	25 MPa 3626 psi	8.001.01
	<i>GVS-4VEP-18-027-ERK</i>	2 l/min 0.53 gpm	25 MPa 3626 psi	8.005.01
	<i>GEI-VE-C021-RPP-SCI-38-SE</i>	30 l/min 7.9 gpm	21 MPa 2987 psi	8.005.11
	<i>GVP-N_LCC-STR</i>	20 l/min 5.3 gpm	25 MPa 3626 psi	8.010.01

**TECHNICAL DATA
 TECHNISCHE ANGABEN**

Max operating pressure Maximaler Betriebsdruck	25 MPa 3556 psi
Max flow Volumenstrom	30 l/min 7.9 gpm
Temperature range Betriebstemperatur	-20°/80°C
Filtration Filtergrad	40µ
Weight/Material Gewicht/Material	1.7 kg
Material	Alloy Aluminium

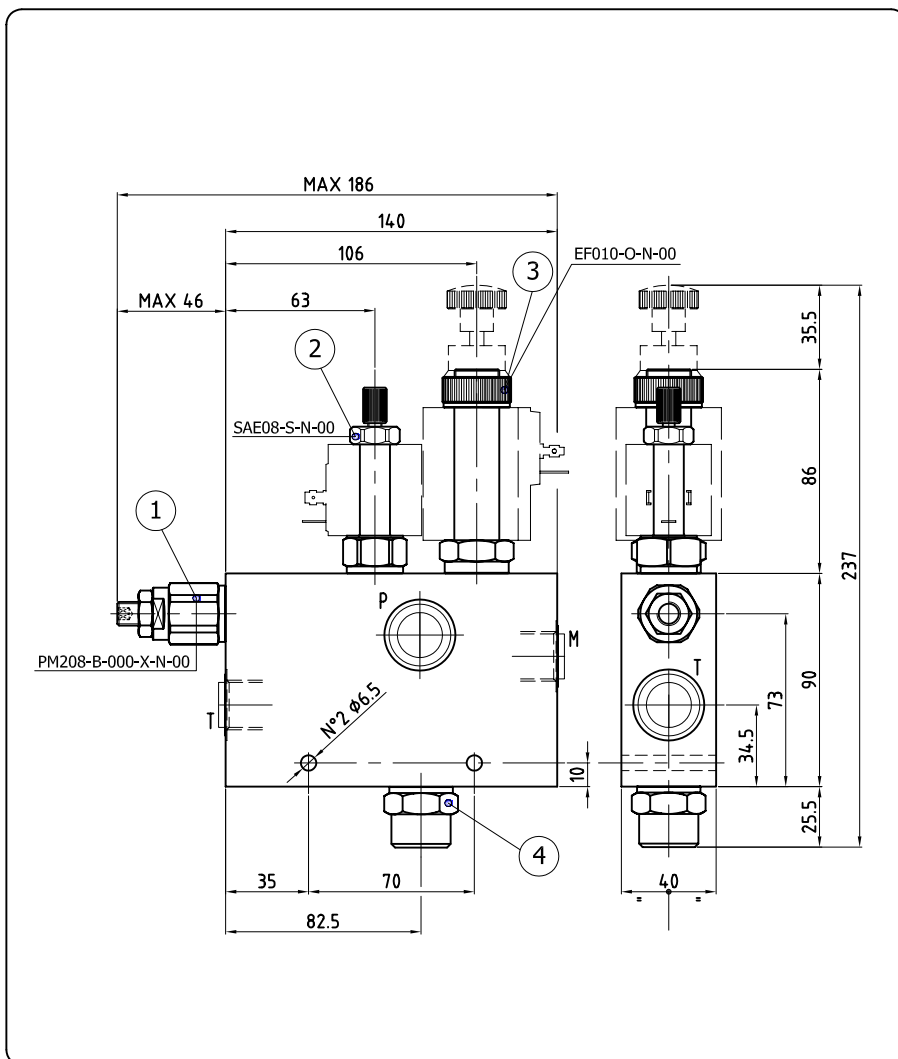
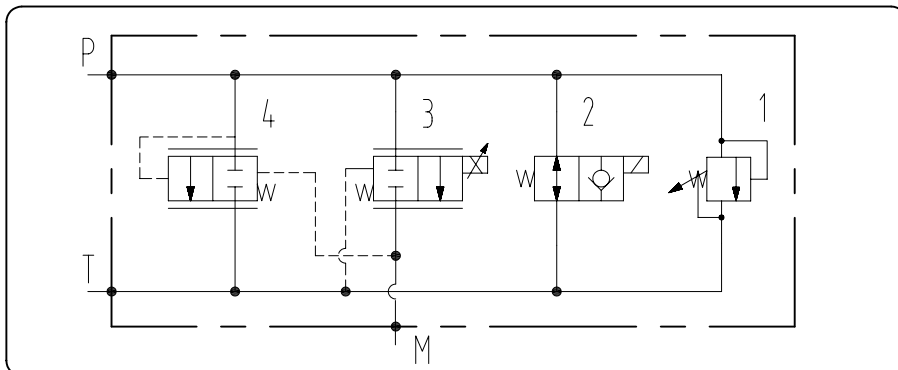
**PORT SIZE
 GEWINDE**

P, T, M	G 1/2"

ORDERING INSTRUCTIONS - BESTELLANLEITUNG

064.11.04.

- [] - [0]

	Voltage Spannung
0	12 VDC
1	24 VDC

TECHNICAL DATA
TECHNISCHE ANGABEN

Max operating pressure Maximaler Betriebsdruck	25 MPa 3555 psi
Max flow Volumenstrom	2 l/min 0.53 gpm
Temperature range Betriebstemperatur	-20°/80°C
Filtration Filtergrad	10µ
Weight Gewicht	1.2 kg
Material Material	Alloy Aluminium

TECHNICAL DATA OF THE VALVES
TECHNISCHE ANGABEN DER VENTILE

Max operating pressure in 2 Maximaler Betriebsdruck	35 MPa 5076 psi
Reduced pressure in 1 Reduzierter Betriebsdruck	4-25 bar
I Max (±10%) for coil 12VDC I max (±10%) für Spule 12VDC	1.15 A
I Min (±10%) for coil I min (±10%) für Spule	0.4 A
Recommended PWM frequency Empfohlene PWM Frequenz	120-150 Hz
Leakage Leckölstrom	5 cc ³ /min

PORT SIZE
GEWINDE

P, T, A1, A2, A3, A4	G 1/8"

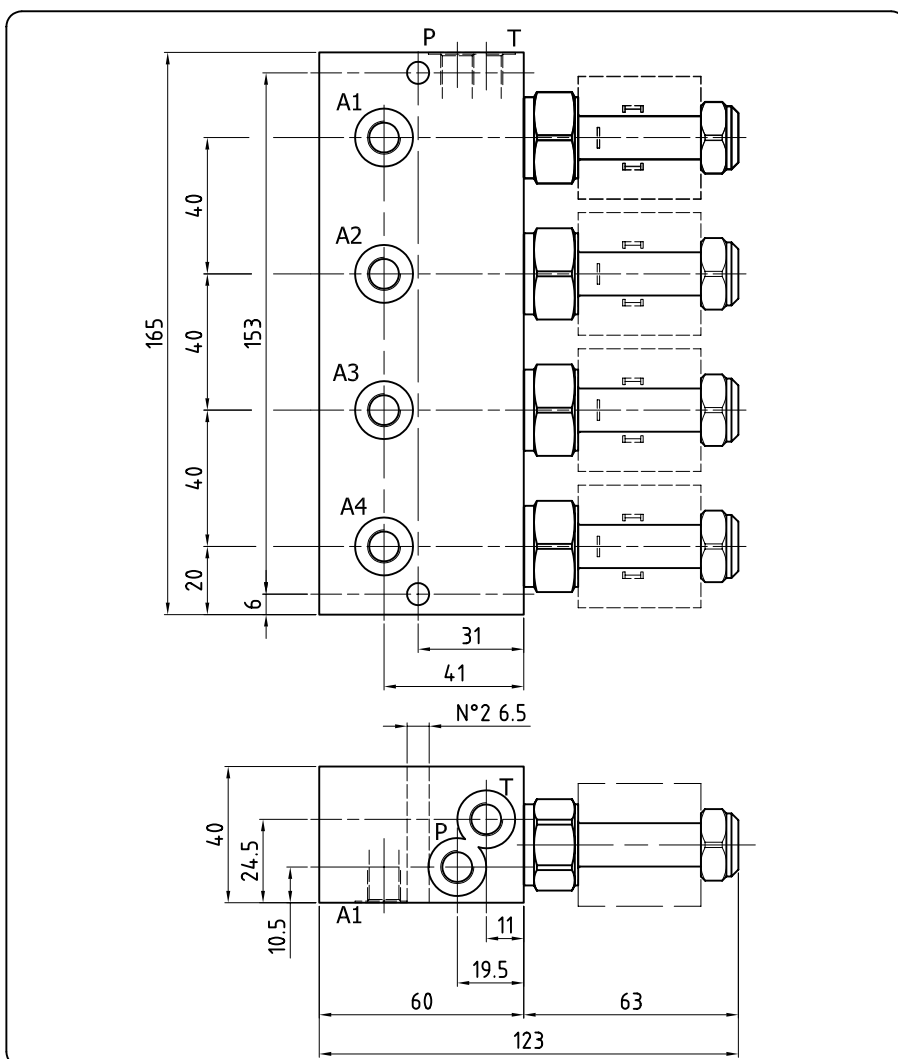
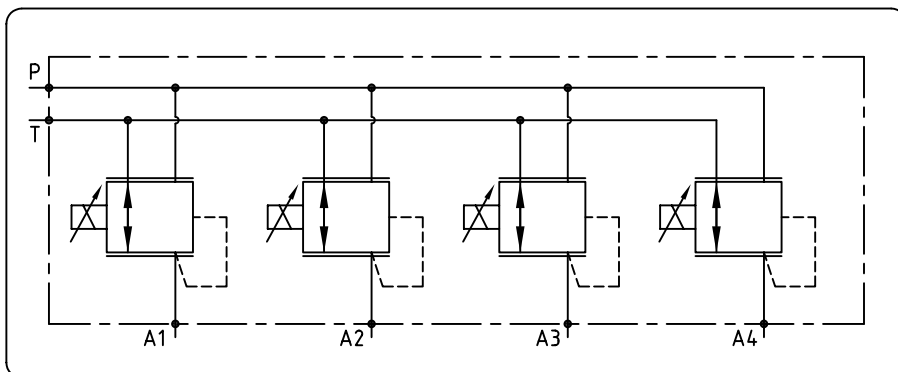
ORDERING INSTRUCTIONS - BESTELLANLEITUNG
027.10.10.
- [] - [0]

Voltage Spannung	
0	12 VDC
1	24 VDC

**TECHNICAL DATA
 TECHNISCHE ANGABEN**

Max operating pressure Maximaler Betriebsdruck	21 MPa 2987 psi
Max flow Volumenstrom	30 l/min 7.9 gpm
Temperature range Betriebstemperatur	-25°/110°C
Filtration Filtergrad	25µ
Weight Gewicht	0.5 kg
Material Material	Alloy Aluminium

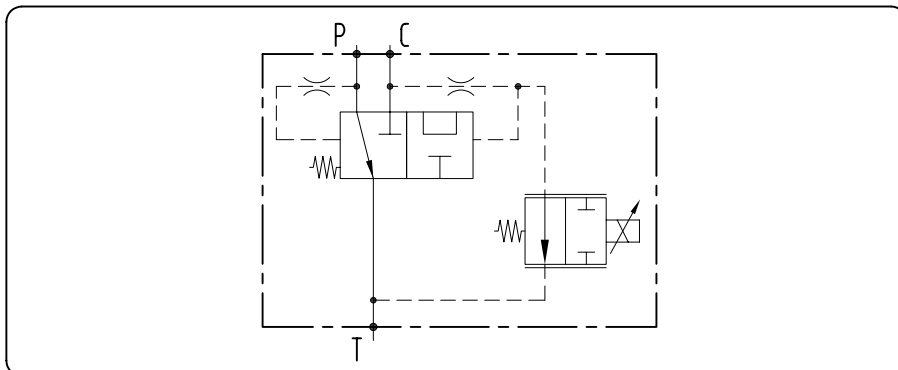
**TECHNICAL DATA OF THE VALVE
 TECHNISCHE ANGABEN DES VENTILS**

Pressure setting tolerance Toleranz des eingestellten Druckwertes	± 5%
I Max (±10%) for coil 12VDC I max (±10%) für Spule 12VDC	1 A
I Min (±10%) for coil 12VDC I min (±10%) für Spule 12VDC	0.2 A
Recommended PWM frequency Empfohlene PWM Frequenz	200 Hz
Response time for control step Reaktionszeit der Steuerung	80 ms
Ohmic resistance of the coil Ohmscher Widerstand der Spule	7.2 Ω
Ohmic resistance of the potentiometer control Ohmscher Widerstand des Potentiometers	1÷10 KΩ

**PORT SIZE
 GEWINDE**

P, T, C	G 3/8"

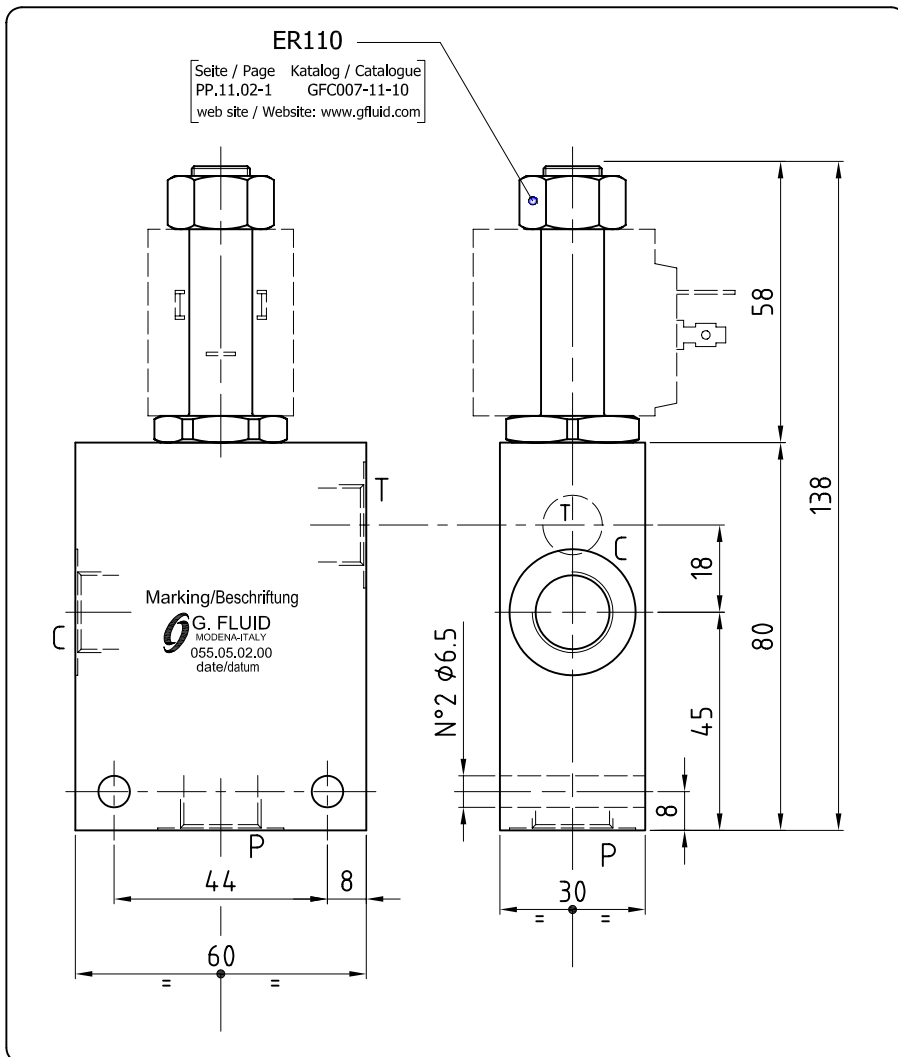
ORDERING INSTRUCTIONS - BESTELLANLEITUNG
055.05.02.00

GVP-N_-LCC-STR

TECHNICAL DATA TECHNISCHE ANGABEN

Max operating pressure in P/A Maximaler Betriebsdruck in P/A	25 MPa 3556 psi
Max operating pressure in T Maximaler Betriebsdruck in T	10 MPa 1422 psi
Max flow Volumenstrom	20 l/min 5.3 gpm
PWM	120 Hz
Temperature range Betriebstemperatur	-20°/80°C
Filtration Filtergrad	10µ
Weigth Gewicht	1.0 kg

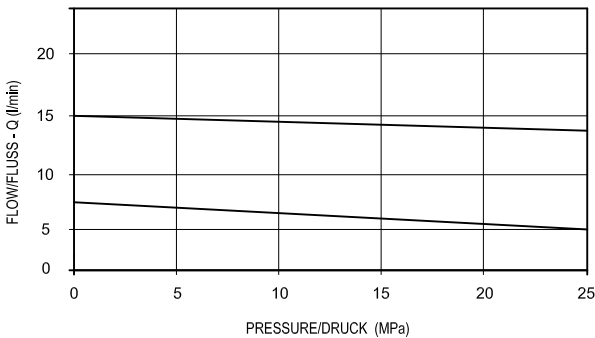

GVP-NC-LCC-STR

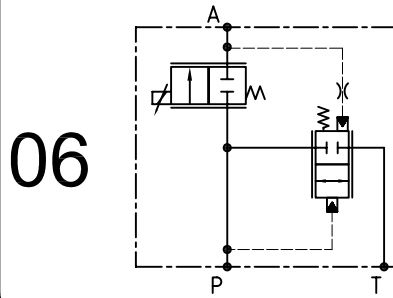

GVP-NA-LCC-STR

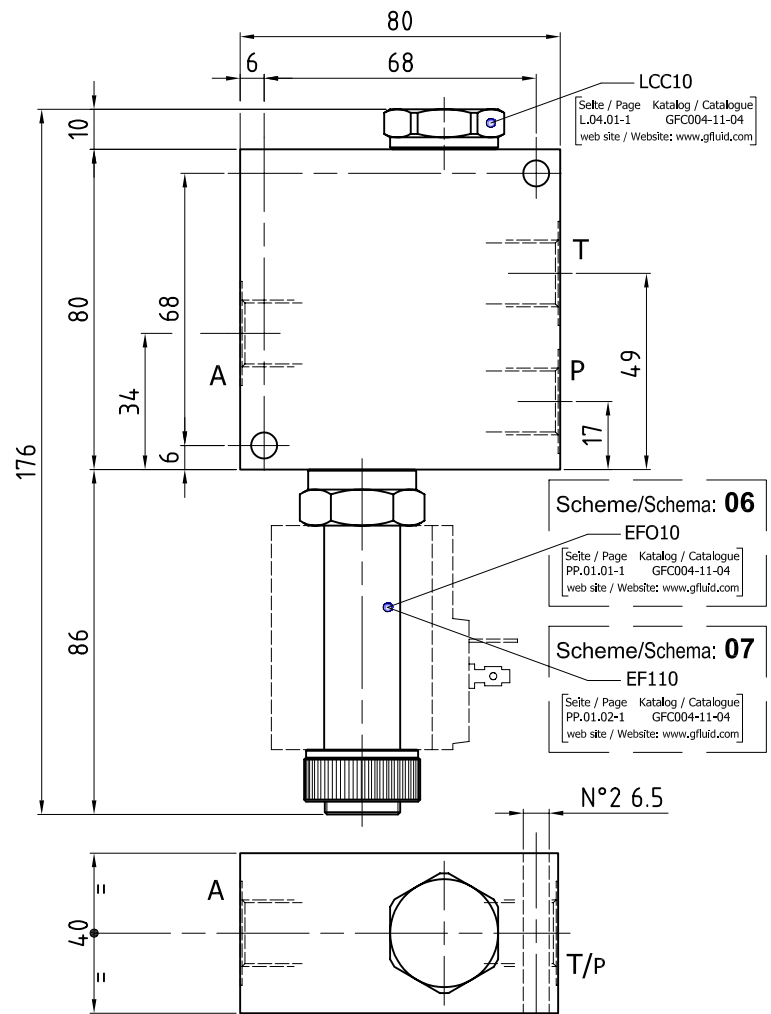
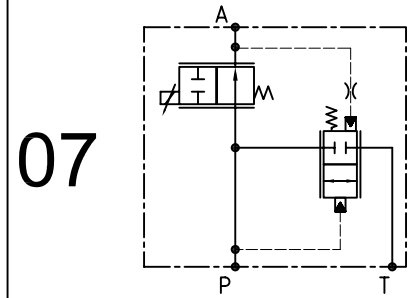



ORDERING INSTRUCTIONS - BESTELLANLEITUNG

38001 - - - - - - - 00

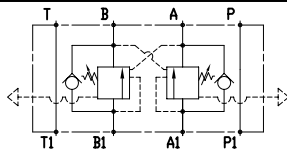
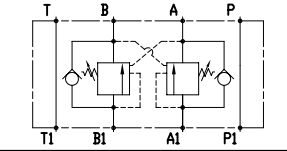
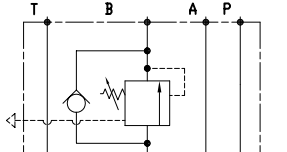
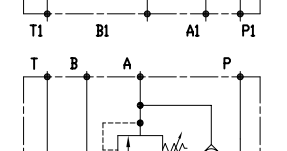
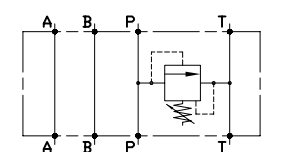
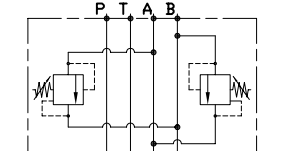
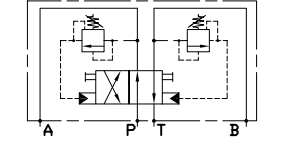
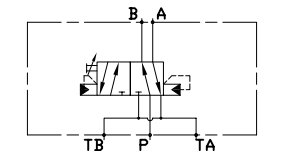
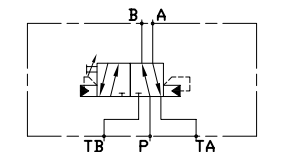
Scheme/Schema		Flow/Durchfluß		Port size/Gewinde		Voltage/Spannung		Material/Material	
06	GVP-NC-LCC-STR	20	20 l/min	2	3/8 BSPP	1	12 VDC	0	Alloy/Aluminium
07	GVP-NA-LCC-STR					2	24 VDC		

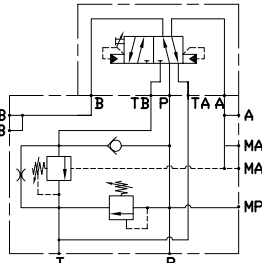
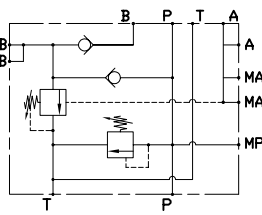
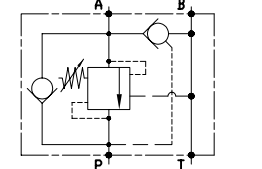
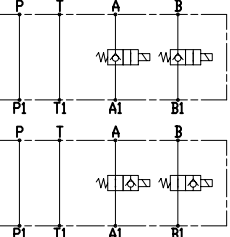
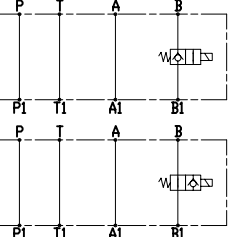
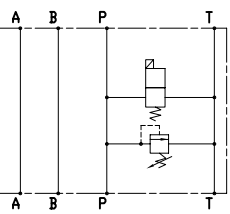
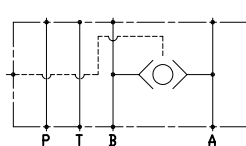
Schema Schema	Description Bezeichnung	max flow max Durchfluß	max pressure max Arbeitsdruck	page Seite
	GEM-B-06-DE-122	60 l/min 15.9 gpm	25 MPa 3626 psi	9.001.01
	GEM-B-10-DE-123	80 l/min 21.1 gpm	25 MPa 3626 psi	9.001.02
	GEM-06-SE-B	60 l/min 15.9 gpm	25 MPa 3626 psi	9.001.11
	GEM-06-SE-A			
	GEM-06-VMG31-004-RJK GEM-ES06-VMG80 GEM-10-VMG80-005-RJK	30 l/min-7.9 gpm	25 MPa-3626 psi	9.002.01
		80 l/min-21.1 gpm	35 MPa-5076 psi	9.002.03
		80 l/min-21.1 gpm	25 MPa-3626 psi	9.002.05
	GEM-ES-06-PM022	40 l/min 10.6 gpm	35 MPa 5076 psi	9.003.02
	GEM-06-ADV-25 GEM-10-ADV-26	40 l/min-10.6 gpm	30 MPa 4350 psi	9.003.52
		90 l/min-23.8 gpm		9.003.56
	GEM-10-ADV-27	80 l/min 21.1 gpm	30 MPa 4350 psi	9.003.60
	GEM-10-ADV-31	80 l/min 21.1 gpm	30 MPa 4350 psi	9.003.64

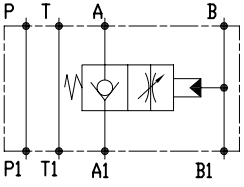
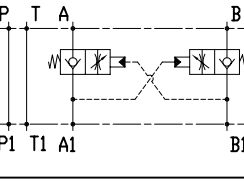
Scheme Schema	Description Bezeichnung	max flow max Durchfluß	max pressure max Arbeitsdruck	page Seite
	GEM-10-ADV-RIG-28	100 l/min 26.4 gpm	35 MPa 5076 psi	9.003.70
	GEM-10-RIG-29	100 l/min 26.4 gpm	35 MPa 5076 psi	9.003.80
	GEM-06-PB-RIG	30 l/min 7.9 gpm	35 MPa 5076 psi	9.010.01
	GEM-06-E-0508S GEM-06-E-0608S	40 l/min 10.6 gpm	35 MPa 5076 psi	9.013.01
	GEM-06-E-0908S GEM-06-E-1008S	40 l/min 10.6 gpm	35 MPa 5076 psi	9.015.01
	GEM-06P-N-R	40 l/min 10.6 gpm	35 MPa 5076 psi	9.020.01
	GEM-ES-45-S	80 l/min 21.1 gpm	35 MPa 5076 psi	9.050.01

Scheme Schema	Description Bezeichnung	max flow max Durchfluß	max pressure max Arbeitsdruck	page Seite
	GEM-VUST-06-CSEIA	40 l/min 10.6 gpm	25 MPa 3626 psi	9.090.10
	GEM-VUST-06-CSEIB			
	GEM-VUST-06-DE	40 l/min 10.6 gpm	25 MPa 3626 psi	9.091.10

GEM-B-06-DE-122

**TECHNICAL DATA
 TECHNISCHE ANGABEN**

Max operating pressure Maximaler Betriebsdruck	25 Mpa 3555 psi
Max flow Volumenstrom	60 l/min 15.9 gpm
Temperature range Betriebstemperatur	-20°/80°C
Filtration Filtergrad	25µ
Weight Gewicht	0.9 kg
Material	Alloy Alluminium
Flangeable Flanschbar	ISO 4401-03-02-0-05 (CETOP 4.2-4-03-320)

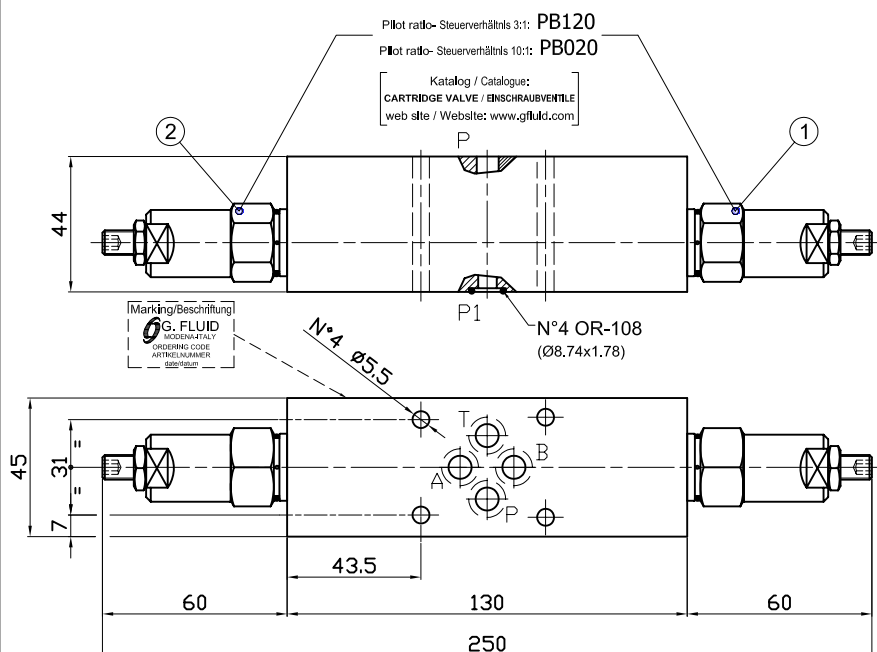
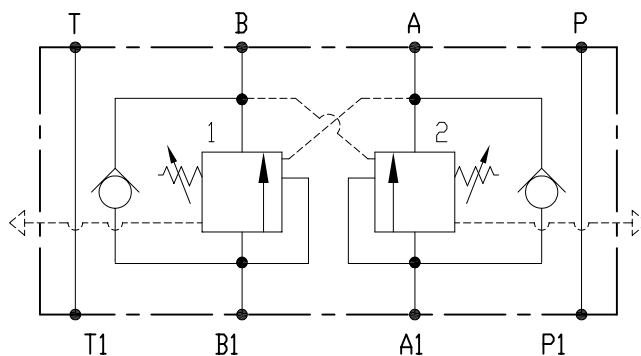
ORDERING CODE - ARTIKELNUMMER
41512122 00

	Pilot ratio Steuerverhältnis	Adj. range Regelbereich	std setting Standardeinst.	Pressure increase MPa/turn Drucksteigerung MPa je Schraubendrehung
3	3:1 (PB120)	1 5-10 MPa	10 MPa	1.0
9	10:1 (PB020)	2 10-35 MPa	25 MPa	4.8

An overcenter valve with compact dimensions and good tolerance to oil contamination. It uses same components as PB016 valve, with excellent control in a wide flow and pressure range. The steel body is designed for heavy duty applications and can be sandwich-mounted on CETOP 5 (size 10) flanges. Pressure setting at least 1.3 times the load induced pressure.

Dieses Ventil ist durch seine kompakten Maße und seine gute Toleranz bezüglich einer eventuellen Överschmutzung gekennzeichnet. Es besteht aus den gleichen Komponenten wie das Ventil PB016. Dank seines Stahlgehäuses ist dieses Ventil auch für schwere Anwendungen geeignet und kann gemäß dem Verkettungssystem DIN/ISO/CETOP-5 (NG 10) montiert werden. Sehr gute Kontrolle innerhalb eines weiten Volumenstrom- und Druckbereiches. Druckeinstellung 1.3x Ladedruck.

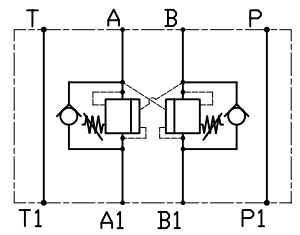
**TECHNICAL DATA
 TECHNISCHE ANGABEN**

Max operating pressure Maximaler Betriebsdruck	25 MPa 3626 psi
Max flow Volumenstrom	80 l/min 21.1 gpm
Temperature range Betriebstemperatur	-20°/80°C
Filtration Filtergrad	25µ
Pilot ratio Versteuerverhältnis	4.6:1
Weight Gewicht	3.4 kg

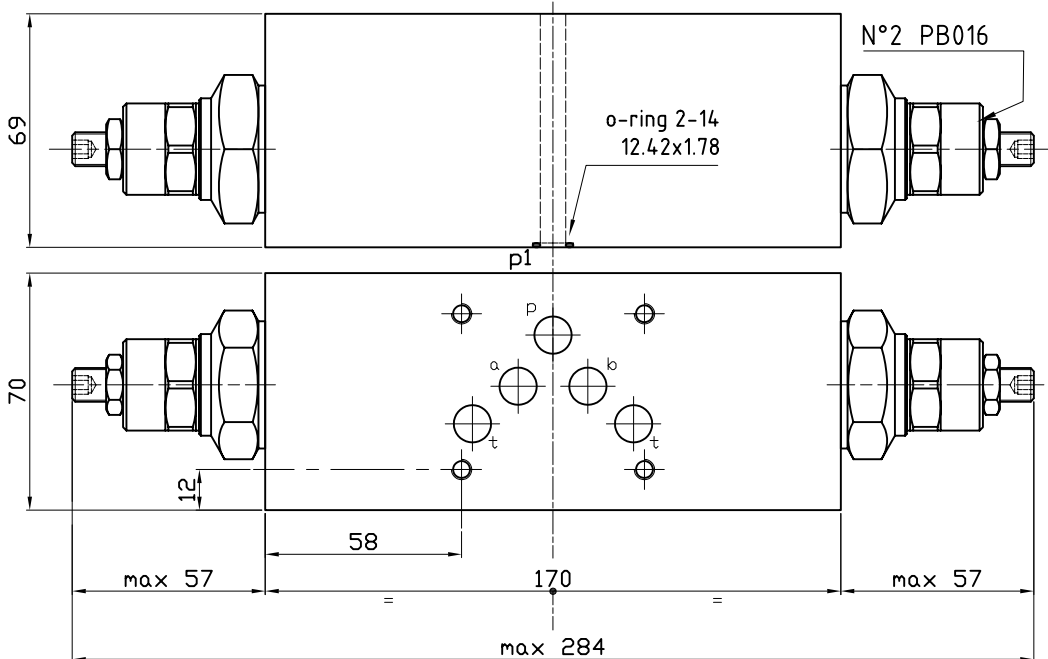
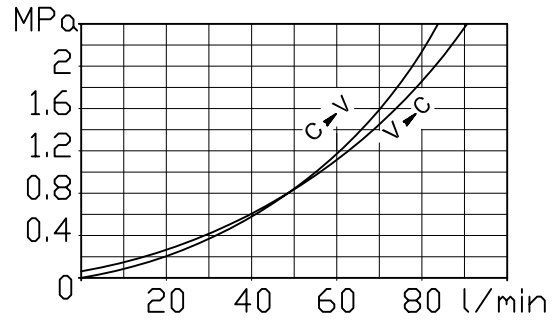
ORDERING INSTRUCTIONS - BESTELLANLEITUNG
415221234 - 00

X	Spring pressure range Feder-Einstellbereich	Standard setting MPa Standardeinstellung MPa
1	6-20 MPa	12
2	10-35 MPa	25

GEM-06-SE-

TECHNICAL DATA TECHNISCHE ANGABEN	
Max operating pressure Maximaler Betriebsdruck	25 Mpa 3555 psi
Max flow Volumenstrom	60 l/min 15.9 gpm
Temperature range Betriebstemperatur	-20°/80°C
Filtration Filtergrad	25µ
Weight Gewicht	0.6 kg
Material	Alloy Alluminium
Flangeable Flanschbar	ISO 4401-03-02-0-05 (CETOP 4.2-4-03-320)

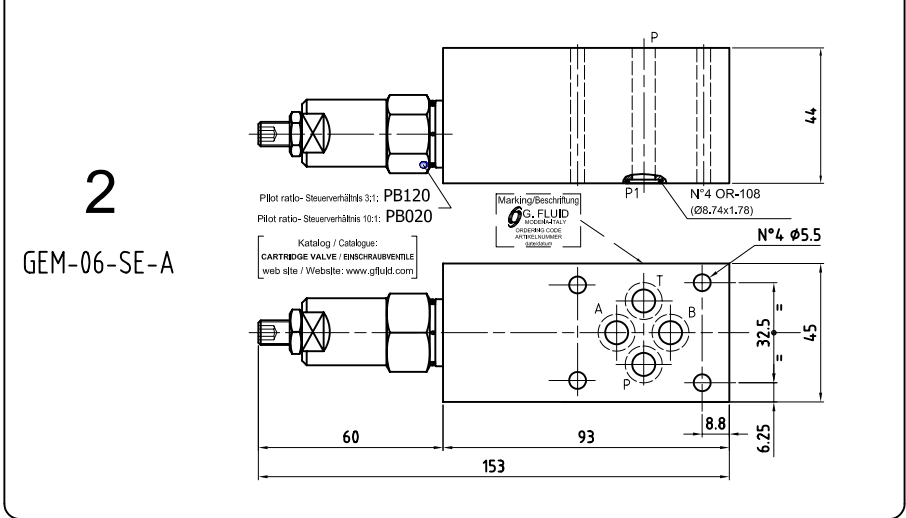
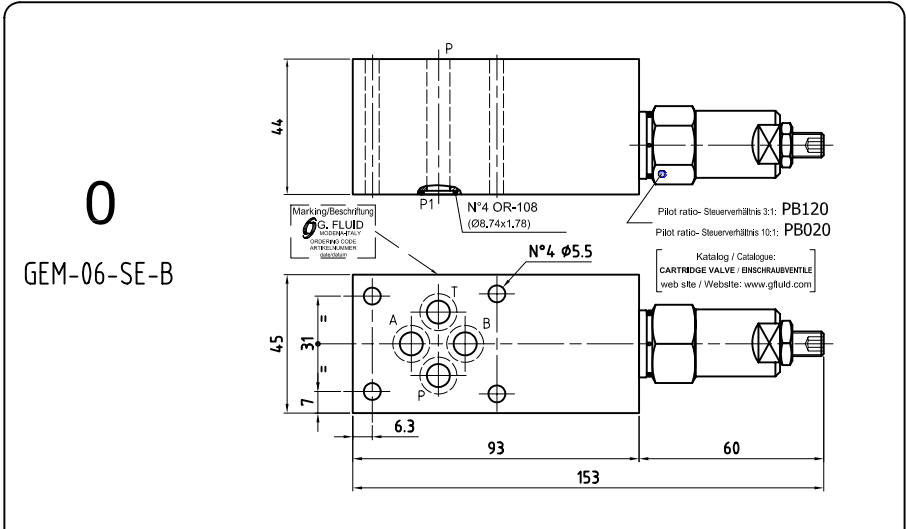
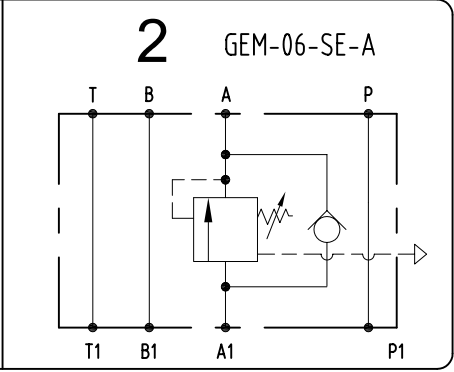
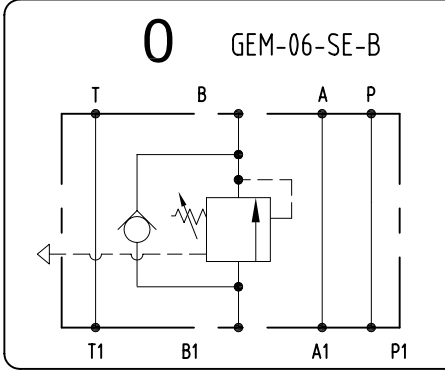

ORDERING CODE - ARTIKELNUMMER

41512 22 00

	Scheme Schema	Pilot ratio Steuerverhältnis	Adj. range Regelbereich	std setting Standardeinst.	Pressure increase MPa/tum Drucksteigerung MPa je Schraubendrehung
0	GEM-06-SE-B	3 3:1 (PB120)	1 5-10 MPa	10 MPa	1.0
2	GEM-06-SE-A	9 10:1 (PB020)	2 10-35 MPa	25 MPa	4.8

GEM-06-VMG31-004-RJK

**TECHNICAL DATA
 TECHNISCHE ANGABEN**

Max operating pressure Maximaler Betriebsdruck	25 MPa 3555 psi
Max flow Volumenstrom	30 l/min 7.9 gpm
Temperature range Betriebstemperatur	-20°/80°C
Filtration Filtergrad	40µ
Weight Gewicht	1.2 kg
Material Material	Alloy Aluminium

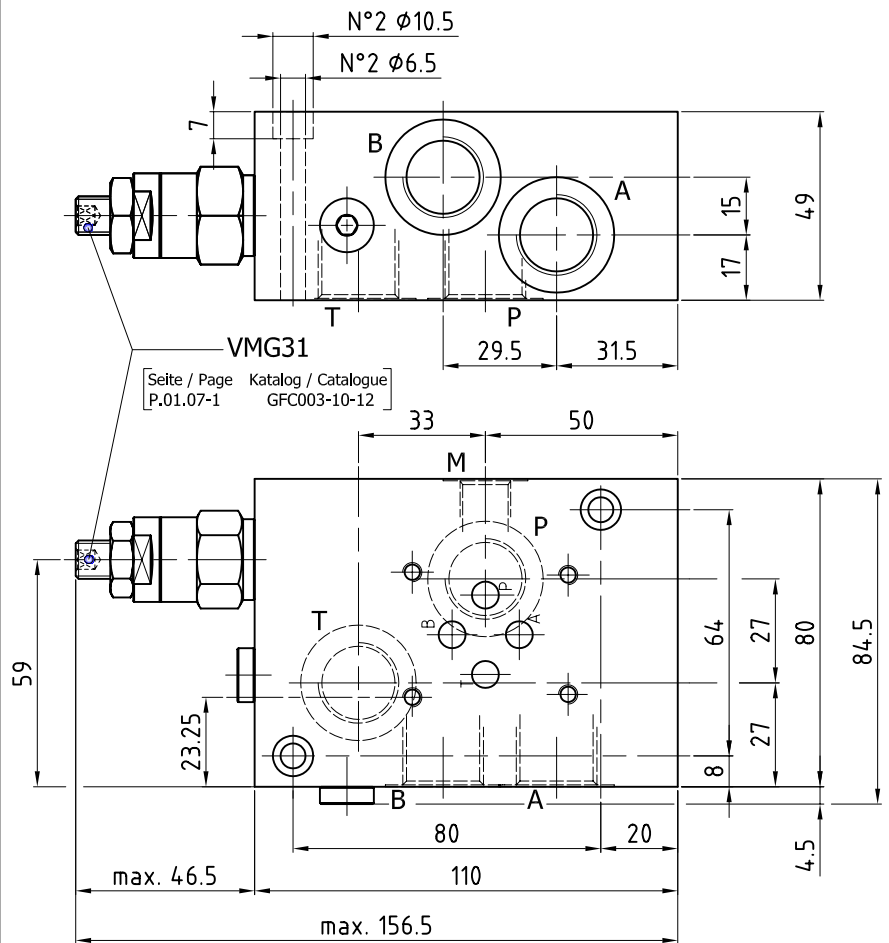
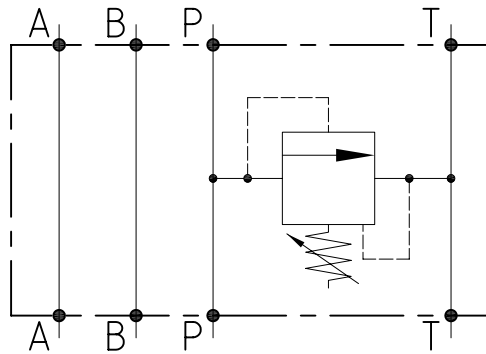
**PORT SIZE
 GEWINDE**

P, T, A, B	G 1/2"
M	G 1/4"

VMG31

Spring pressure range Feder-Einstellbereich	Pressure increase MPa/turn Drucksteigerung MPa je Schraubendrehung	Standard setting MPa Standard Einstellung MPa
5-21 MPa	2.8	21

**ORDERING INSTRUCTIONS
 BESTELLANLEITUNG**
004.01.09.00

GEM-ES06-VMG80

TECHNICAL DATA TECHNISCHE ANGABEN

Max operating pressure Maximaler Betriebsdruck	25 MPa-3555 psi (Alloy/Aluminium) 35 MPa-5076 psi (Zincoated Steel/Verzink. Stahl)
Max flow Volumenstrom	80 l/min 21.1 gpm
Temperature range Betriebstemperatur	-20°/80°C
Filtration Filtergrad	40µ

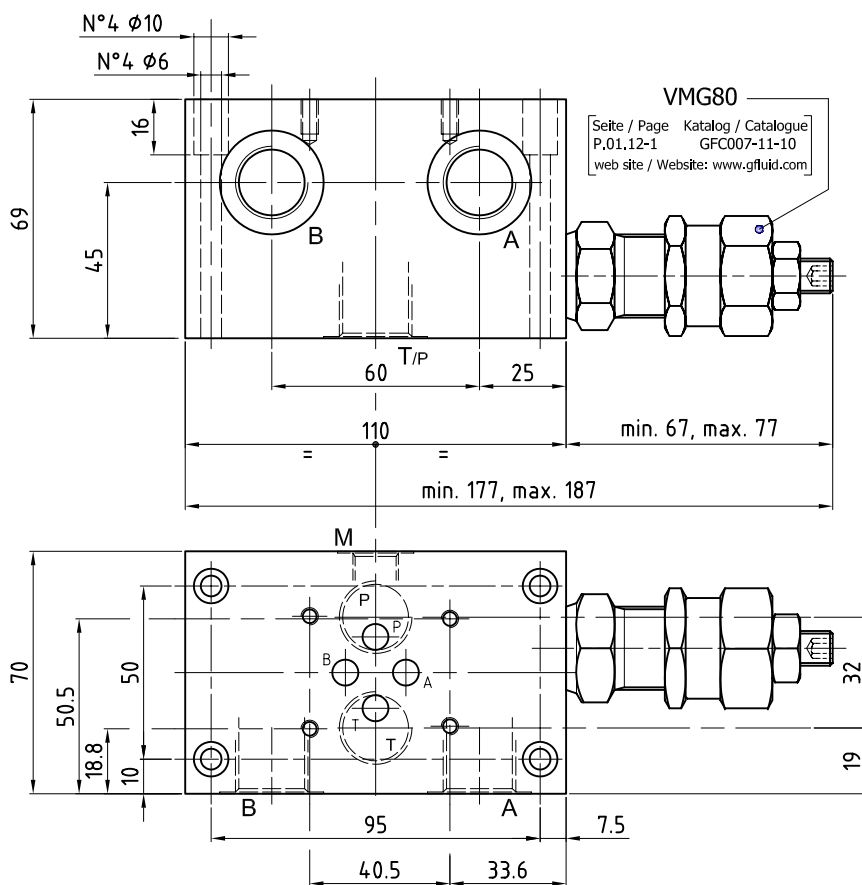
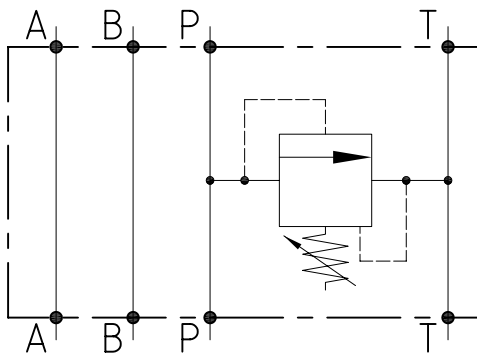

PORT SIZE GEWINDE

P, T, A, B	G 1/2"
------------	--------

M	G 1/4"
---	--------

ORDERING INSTRUCTIONS - BESTELLANLEITUNG

4 - [] - 24 00 61 - [] - [] - 00

	Material	Weight
	Material	Gewicht
0	Alloy/Aluminium	1.5 kg
1	Zincoated steel Verzinkter Stahl	4.2 kg

	Adjustment options
	Einstellung
1	leakproof socket screw leckölfreie Regulierungsschraube
2	handknob and locknut Handrad und Mutter

	Adjustment range
	Regelbereich
1	1-5 MPa
2	3.5-10 MPa
3	8-25 MPa

GEM-10-VMG80-005-RJK

TECHNICAL DATA
TECHNISCHE ANGABEN

Max operating pressure Maximaler Betriebsdruck	25 MPa 3555 psi
Max flow Volumenstrom	80 l/min 21.1 gpm
Temperature range Betriebstemperatur	-20°/80°C
Filtration Filtergrad	40µ
Weight Gewicht	1.2 kg
Material Material	Alloy Aluminium

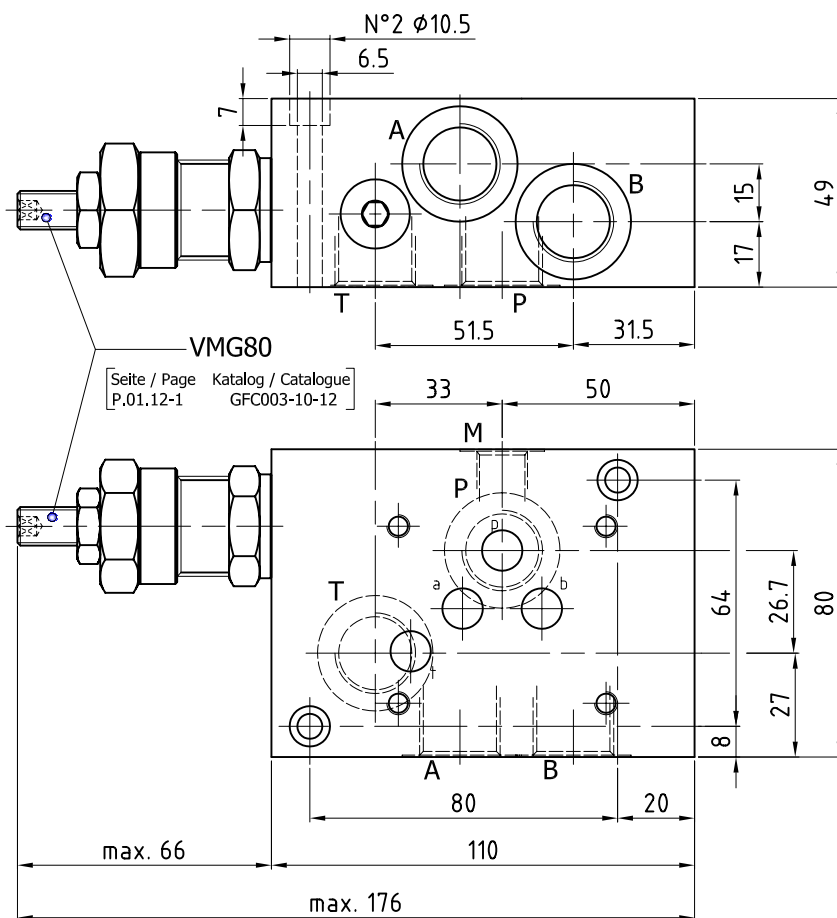
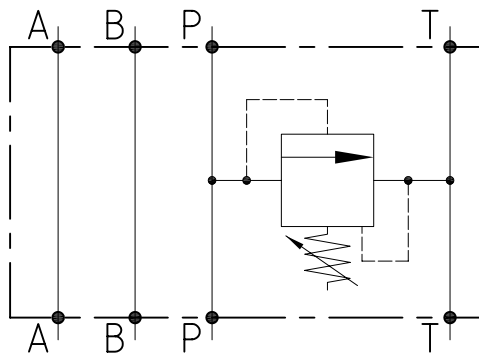
PORT SIZE
GEWINDE

P, T, A, B	G 1/2"
M	G 1/4"

VMG80

Spring pressure range Feder-Einstellbereich	Pressure increase MPa/turn Drucksteigerung MPa je Schraubendrehung	Standard setting MPa Standard Einstellung MPa
8-25 MPa	2.0	14.5

ORDERING INSTRUCTIONS
BESTELLANLEITUNG
005.01.09.00

TECHNICAL DATA
TECHNISCHE ANGABEN

Max operating pressure Maximaler Betriebsdruck	25 MPa-3626 psi (Alloy/Aluminium) 35 MPa-5076 psi (Zincoated Steel/Verzink. Stahl)
Max flow Volumenstrom	40 l/min 10.6 gpm
Temperature range Betriebstemperatur	-20°/80°C
Filtration Filtergrad	25µ
Flangeable Flanschbar	ISO 4401-03-02-0-05 (CETOP 4.2-4-03-320)

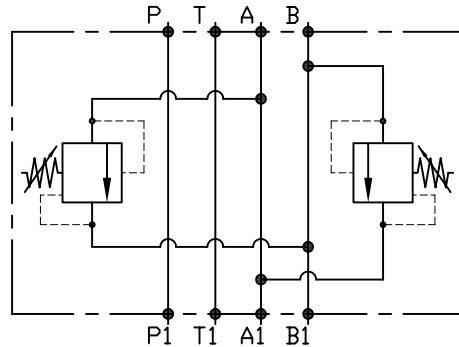
RELIEF VALVE - PM022:

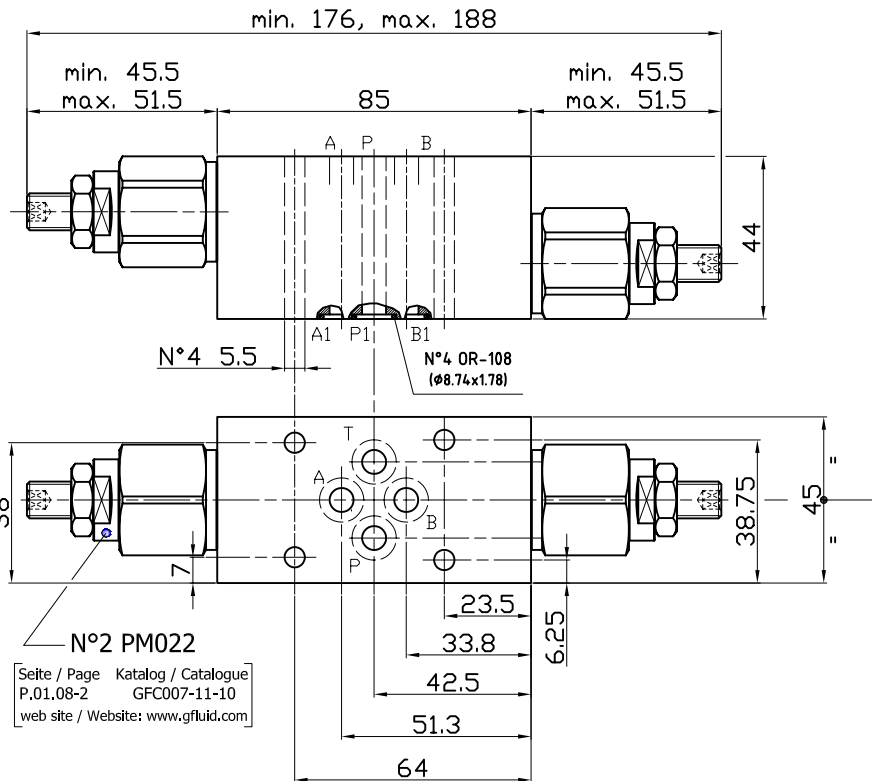
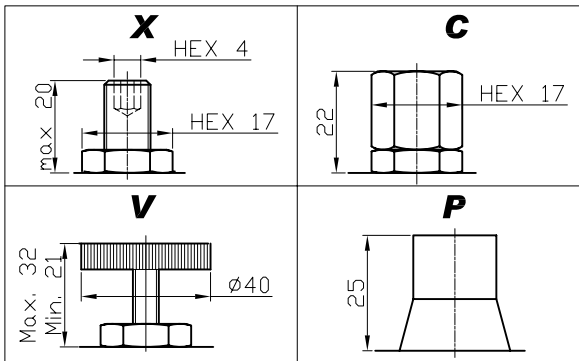
 Adjustment options
 Einstellungen

 N°2 PM022
 Seite / Page Katalog / Catalogue
 P.01.08-2 GFC007-11-10
 web site / Website: www.gfluid.com

ORDERING INSTRUCTIONS - BESTELLANLEITUNG
4 - **—** - **24 00 95** - **—** - **—** - **00**

	Material	Weight
	Material	Gewicht
0	Alloy/Aluminium	0.5 kg
1	Zincoated steel Verzinkter Stahl	1.4 kg

Adjustment options
Einstellungen
X
C
V
P

Adjustment range	
Regelbereich	
1	1-6 MPa
2	5-20 MPa
3	20-35 MPa

GEM-06-ADV-25

TECHNICAL DATA TECHNISCHE ANGABEN

Max operating pressure Maximaler Betriebsdruck	30 MPa 4350 psi
Max flow Volumenstrom	40 l/min 10.6 gpm
Temperature range Betriebstemperatur	-20°/80°C
Filtration Filtergrad	40µ
Material/Material Weight/Gewicht	Cast iron/Gusseisen 1.5 kg
Flangeable Flanschbar	ISO 4401-03-02-0-05 (CETOP 4.2-4-03-320)

Application/Anwendung

Valves with integral pressure reversal are intended to operating oscillating movements of a cylinder.
Fields of application are press controls, assembly robots, feeding systems for wood heating or other systems with pressure dependent resetting.

Ventile mit integrierter Druckumkehr werden zur Erzeugung schwingender Bewegungen eines Zylinders verwendet. Einsatzgebiete sind Maschinensteuerungen, Montageautomaten, Speisung für Holzheizungen oder andere Systeme, die eine automatische Rückkehr des Zylinders erfordern.

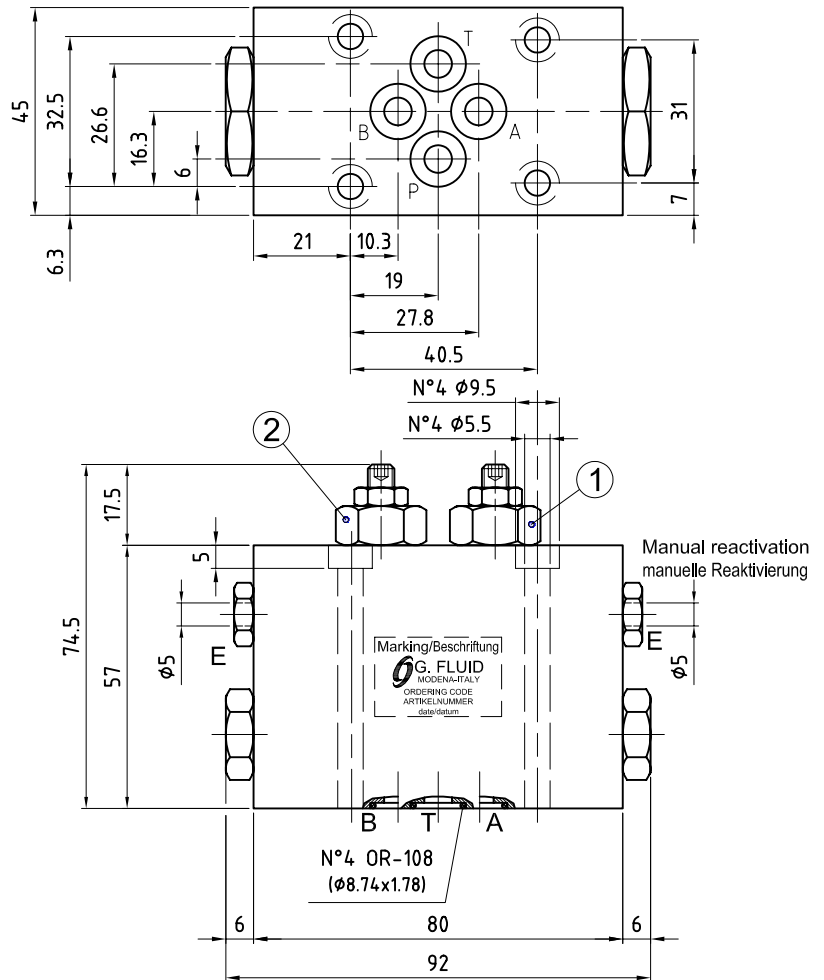
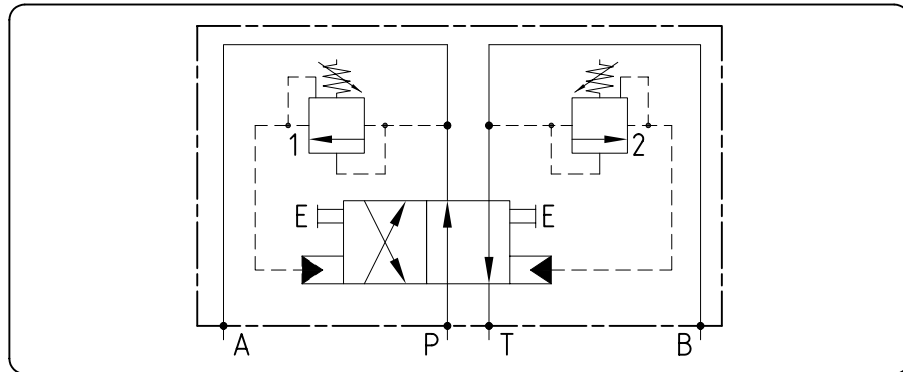
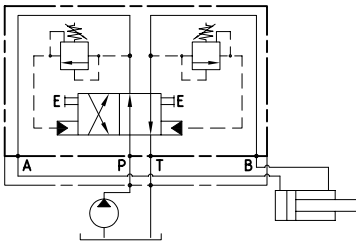

Diagram/Diagramm

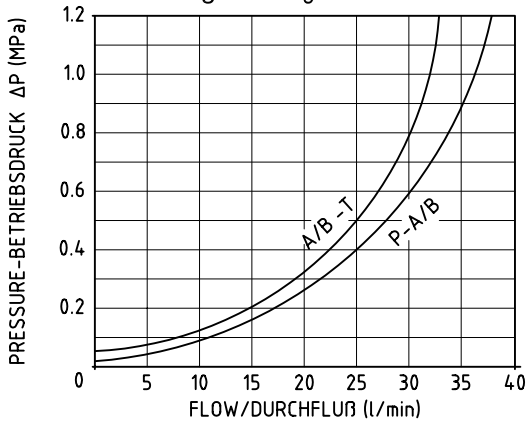

ORDERING CODE - ARTIKELNUMMER

42225 000

Valve/Ventil 1 Adj. range/Regelbereich	std setting Standardeinst.	Pressure increase MPa/turn Drucksteigerung MPa je Schraubendrehung	Valve/Ventil 1 Setting/Einstellung	Valve/Ventil 2 Adj. range/Regelbereich	std setting Standardeinst.	Pressure increase MPa/turn Drucksteigerung MPa je Schraubendrehung	Valve/Ventil 2 Setting/Einstellung
2 5-21 MPa	20 MPa	2.8	000 standard setting Standardeinstellung upon request - auf Anfrage	2 5-21 MPa	20 MPa	2.8	000 standard setting Standardeinstellung upon request - auf Anfrage
3 10-35 MPa	35 MPa	6.6	075 7.5 MPa	3 10-35 MPa	35 MPa	6.6	075 7.5 MPa
		 MPa			 MPa

GEM-10-ADV-26

TECHNICAL DATA TECHNISCHE ANGABEN

Max operating pressure Maximaler Betriebsdruck	30 MPa 4350 psi
Max flow Volumenstrom	90 l/min 23.8 gpm
Temperature range Betriebstemperatur	-20°/80°C
Filtration Filtergrad	40µ
Material/Material Weight/Gewicht	Cast iron/Gusseisen 2.6 kg
Flangeable Flanschbar	ISO 4401-05-04-0-94 (CETOP 4.2-4-05-320)

Application/Anwendung

Valves with integral pressure reversal are intended to operating oscillating movements of a cylinder.
Fields of application are press controls, assembly robots, feeding systems for wood heating or other systems with pressure dependent resetting.

Ventile mit integrierter Druckumkehr werden zur Erzeugung schwingender Bewegungen eines Zylinders verwendet. Einsatzgebiete sind Maschinensteuerungen, Montageautomaten, Speisung für Holzheizungen oder andere Systeme, die eine automatische Rückkehr des Zylinders erfordern.

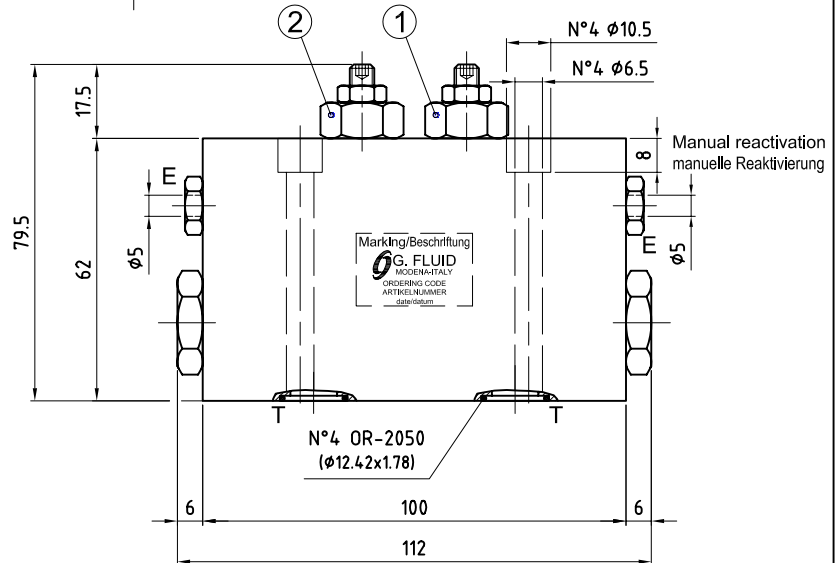
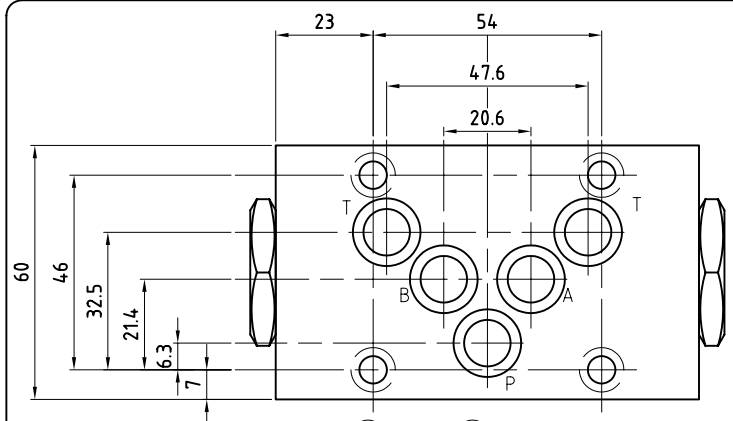
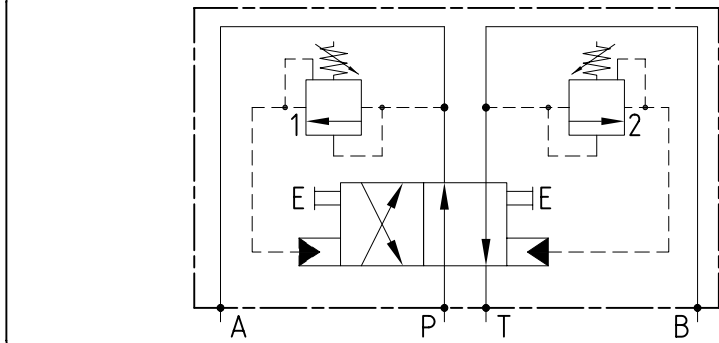
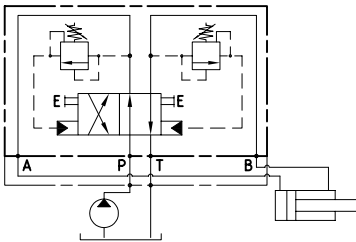

Minimum required flow/Minstdurchflußmenge: 3 l/min - 0.79 gpm

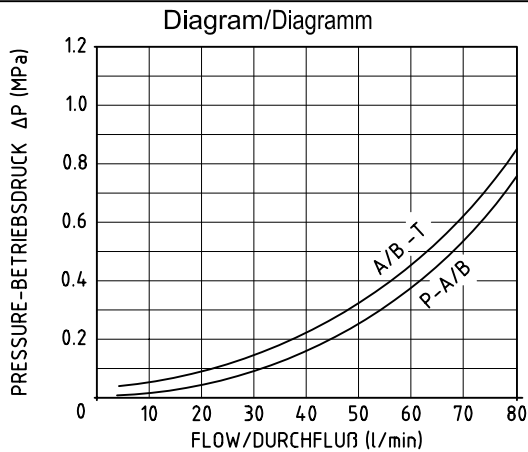

ORDERING CODE - ARTIKELNUMMER

42326 000

Valve/Ventil 1 Adj. range/Regelbereich	std setting Standardeinst.	Pressure increase MPa/turn Drucksteigerung MPa je Schraubendrehung	Valve/Ventil 1 Setting/Einstellung	Valve/Ventil 2 Adj. range/Regelbereich	std setting Standardeinst.	Pressure increase MPa/turn Drucksteigerung MPa je Schraubendrehung	Valve/Ventil 2 Setting/Einstellung
2 5-21 MPa	20 MPa	2.8	000 standard setting Standardeinstellung upon request - auf Anfrage	2 5-21 MPa	20 MPa	2.8	000 standard setting Standardeinstellung upon request - auf Anfrage
3 10-35 MPa	35 MPa	6.6	075 7.5 MPa	3 10-35 MPa	35 MPa	6.6	075 7.5 MPa
		 MPa			 MPa

GEM-10-ADV-27

TECHNICAL DATA TECHNISCHE ANGABEN

Max operating pressure Maximaler Betriebsdruck	30 MPa 4350 psi
Max flow Volumenstrom	80 l/min 21.1 gpm
Temperature range Betriebstemperatur	-20°/80°C
Filtration Filtergrad	40μ
Material/Material Weight/Gewicht	Cast iron/Gusseisen 3.1 kg
Flangeable Flanschbar	ISO 4401-05-04-0-94 (CETOP 4.2-4-05-320)

Application/Anwendung

Valves with integral pressure reversal are intended to operating oscillating movements of a cylinder.
Fields of application are press controls, assembly robots, feeding systems for wood heating or other systems with pressure dependent resetting.

Ventile mit integrierter Druckumkehr werden zur Erzeugung schwingender Bewegungen eines Zylinders verwendet. Einsatzgebiete sind Maschinensteuerungen, Montageautomaten, Speisung für Holzheizungen oder andere Systeme, die eine automatische Rückkehr des Zylinders erfordern.

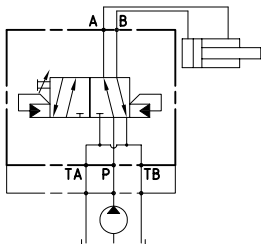

Diagram/Diagramm

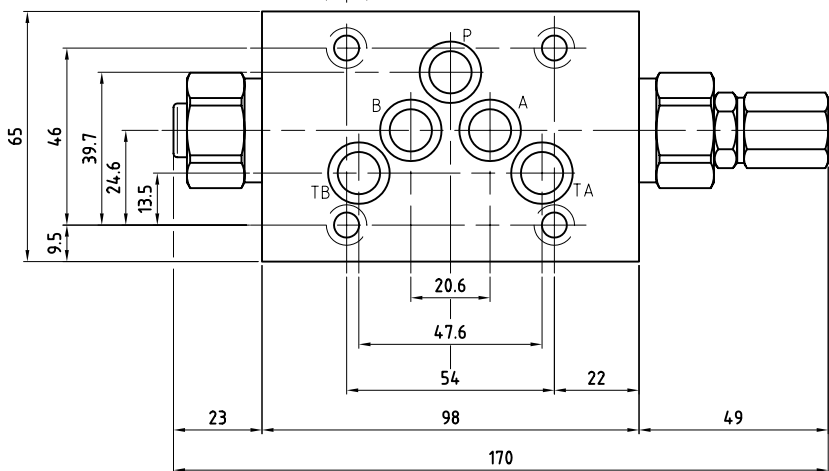
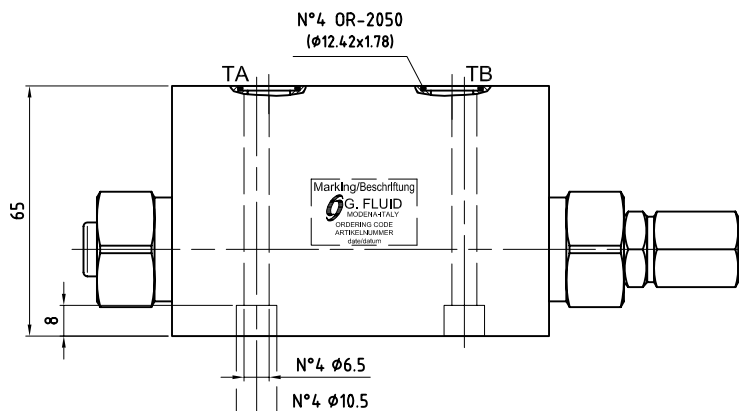
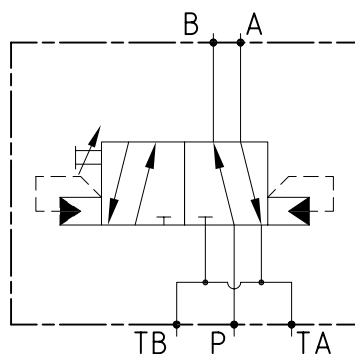
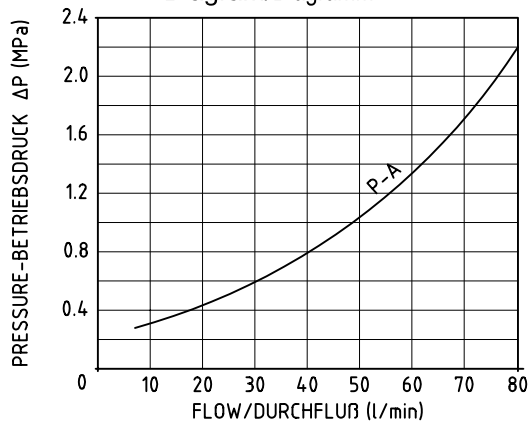

Minimum required flow/Miniesrdurchflußmenge: 7 l/min - 1.85 gpm

ORDERING CODE - ARTIKELNUMMER

423270100000

GEM-10-ADV-31

TECHNICAL DATA TECHNISCHE ANGABEN

Max operating pressure Maximaler Betriebsdruck	30 MPa 4350 psi
Max flow Volumenstrom	80 l/min 21.1 gpm
Temperature range Betriebstemperatur	-20°/80°C
Filtration Filtergrad	40μ
Material/Material Weight/Gewicht	Cast iron/Gusseisen 3.1 kg
Flangeable Flanschbar	ISO 4401-05-04-0-94 (CETOP 4.2-4-05-320)

Application/Anwendung

Valves with integral pressure reversal are intended to operating oscillating movements of a cylinder.
Fields of application are press controls, assembly robots, feeding systems for wood heating or other systems with pressure dependent resetting.

Ventile mit integrierter Druckumkehr werden zur Erzeugung schwingender Bewegungen eines Zylinders verwendet. Einsatzgebiete sind Maschinensteuerungen, Montageautomaten, Speisung für Holzheizungen oder andere Systeme, die eine automatische Rückkehr des Zylinders erfordern.

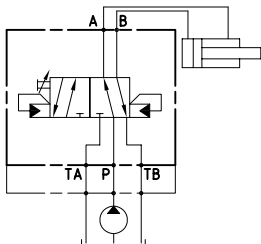

Diagram/Diagramm

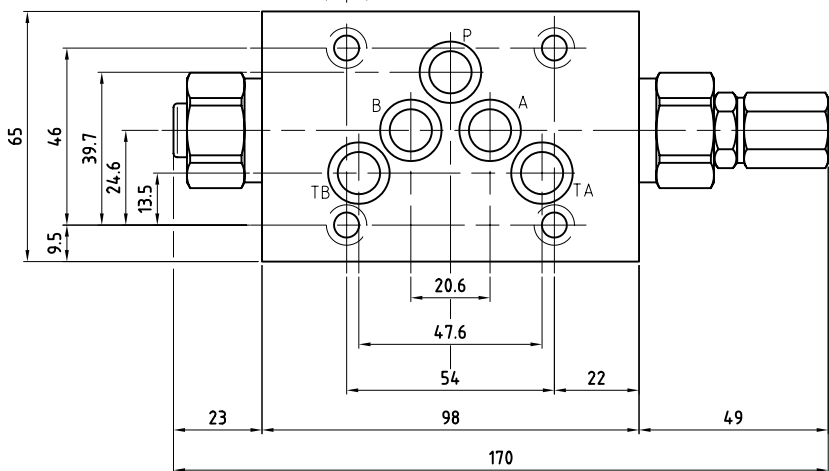
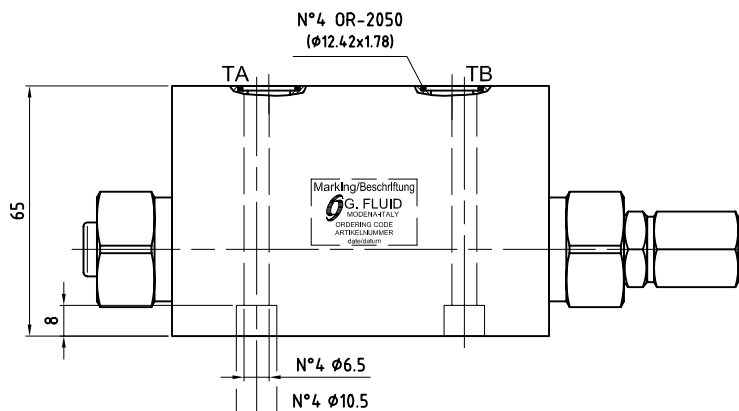
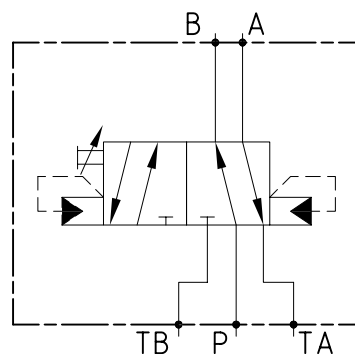
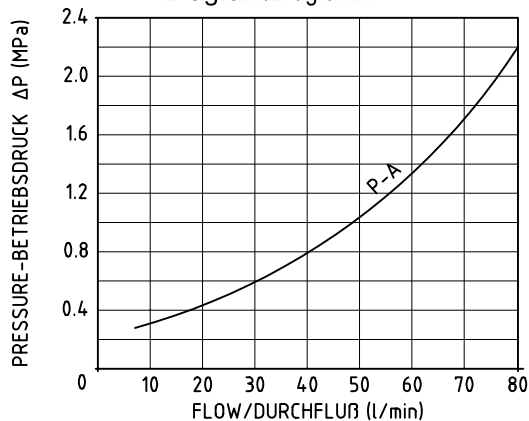

Minimum required flow/Miniesdurchflußmenge: 7 l/min - 1.85 gpm

ORDERING CODE - ARTIKELNUMMER

423310100000

GEM-10-ADV-RIG-28

TECHNICAL DATA TECHNISCHE ANGABEN

Max operating pressure Maximaler Betriebsdruck	35 MPa 5076 psi
Max flow Volumenstrom	100 l/min 26.4 gpm
Temperature range Betriebstemperatur	-20°/80°C
Filtration Filtergrad	40µ
Material/Material Weight/Gewicht	Cast iron - zinc coated steel Gusseisen - Verzinkter Stahl 9 kg
Flangeable Flanschbar	ISO 4401-05-04-0-94 (CETOP 4.2-4-05-320)

Application/Anwendung

Valves with integral pressure reversal are intended to operating oscillating movements of a cylinder. Special subplates with relief valve and integrated regenerative circuit which stops automatically with increasing load. This circuit allows a fast movement of the cylinder with low working pressure followed by an automatic disengagement of the regenerative function at the set pressure, and consequently a higher hydraulic force is available.

The automatic reciprocating valve allows a continuous movement of the cylinder until the pump is stopped. The reciprocating valve has a preferential position which allows the cylinder to begin any working cycle in the same position (P > B).

Fields of application are press controls, assembly robots, feeding systems for wood heating or other systems with pressure dependent resetting.

Ventile mit integrierter Druckumkehr werden zur Erzeugung schwingender Bewegungen eines Zylinders verwendet. Spezialgrundplatten mit Druckbegrenzungsventil und regenerativem Kreislauf, der bei Lastzunahme automatisch abgeschaltet wird. Das System erlaubt eine schnelle Bewegungsgeschwindigkeit des Zylinders im niedrigen Druckbereich. Bei Erreichen des eingestellten Maximaldrucks wird diese Funktion abgeschaltet, sodass eine höhere hydraulisch-mechanische Kraft zur Verfügung steht.

Das automatische Invertventil ermöglicht eine kontinuierliche Bewegung des Zylinders bis zum Anhalten der Pumpe. Dieses Ventil verfügt über eine Vorzugsstellung, die dafür sorgt, dass der Zylinder jeden Arbeitszyklus an derselben Stelle beginnt (P > B).

Einsatzgebiete sind Maschinensteuerungen, Montageautomaten, Speisung für Holzheizungen oder andere Systeme, die eine automatische Rückkehr des Zylinders erfordern.

Diagram/Diagramm

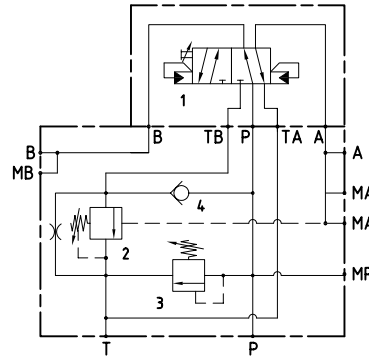
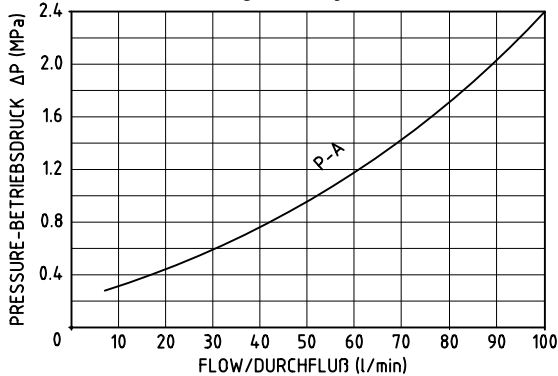

Port size/Gewinde	
P, T, A, B	MP, MA, MB
G 3/4"	G 1/4"

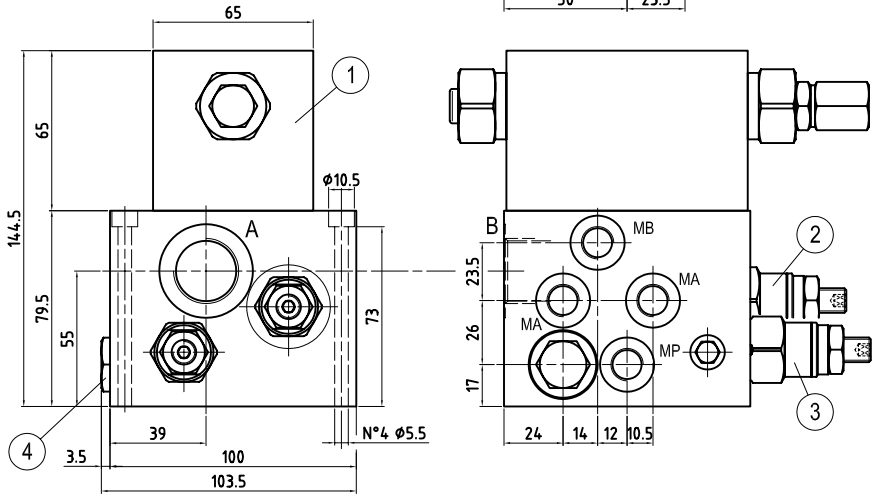
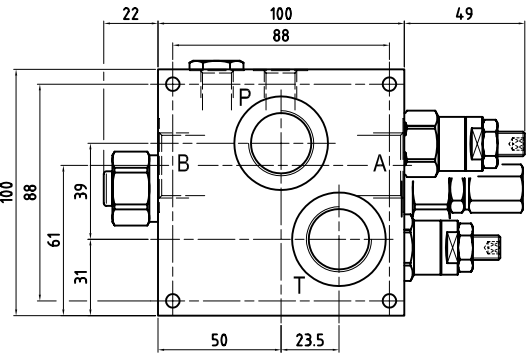

Minimum required flow/Miniesdurchflußmenge: 7 l/min - 1.85 gpm

ORDERING CODE - ARTIKELNUMMER

41328

400

Valve/Ventil 2 Adj. range/Regelbereich	std setting Standardeinst.	Pressure increase MPa/turn Drucksteigerung MPa je Schraubendrehung	Valve/Ventil 2 Setting/Einstellung	Valve/Ventil 3 Adj. range/Regelbereich	std setting Standardeinst.	Pressure increase MPa/turn Drucksteigerung MPa je Schraubendrehung	Valve/Ventil 3 Setting/Einstellung
2 5-21 MPa	10 MPa	2.8	000 standard setting Standardeinstellung	2 5-21 MPa	20 MPa	2.8	000 standard setting Standardeinstellung
3 10-35 MPa	20 MPa	6.6	upon request - auf Anfrage	3 10-35 MPa	35 MPa	6.6	upon request - auf Anfrage
			075 7.5 MPa				075 7.5 MPa
		 MPa			 MPa

GEM-10-RIG-29

TECHNICAL DATA TECHNISCHE ANGABEN

Max operating pressure Maximaler Betriebsdruck	35 MPa 5076 psi
Max flow Volumenstrom	100 l/min 26.4 gpm
Temperature range Betriebstemperatur	-20°/80°C
Filtration Filtergrad	40µ
Material/Material Weight/Gewicht	Cast iron - zinc coated steel 5.7 kg Gusseisen - Verzinkter Stahl
Flangeable Flanschbar	ISO 4401-05-04-0-94 (CETOP 4.2-4-05-320)

Application/Anwendung

Valves with integral pressure reversal are intended to operating oscillating movements of a cylinder. Special subplates with relief valve and integrated regenerative circuit which stops automatically with increasing load. This circuit allows a fast movement of the cylinder with low working pressure followed by an automatic disengagement of the regenerative function at the set pressure, and consequently a higher hydraulic force is available.

Ventile mit integrierter Druckumkehr werden zur Erzeugung schwingender Bewegungen eines Zylinders verwendet. Spezialgrundplatten mit Druckbegrenzungsventil und regenerativem Kreislauf, der bei Lastzunahme automatisch abgeschaltet wird. Das System erlaubt eine schnelle Bewegungsgeschwindigkeit des Zylinders im niedrigen Druckbereich. Bei Erreichen des eingestellten Maximaldrucks wird diese Funktion abgeschaltet, sodass eine höhere hydraulisch-mechanische Kraft zur Verfügung steht.

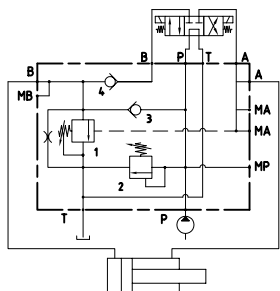

Diagram/Diagramm

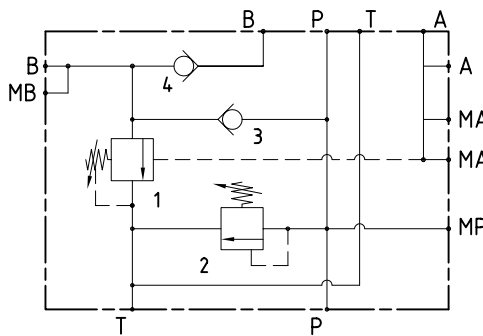
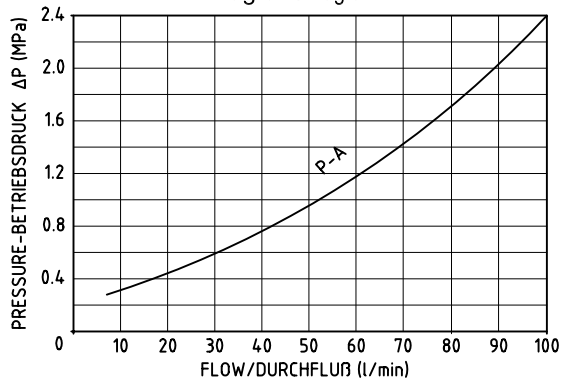

Port size/Gewinde	
P, T, A, B	MP, MA, MB
G 3/4"	G 1/4"

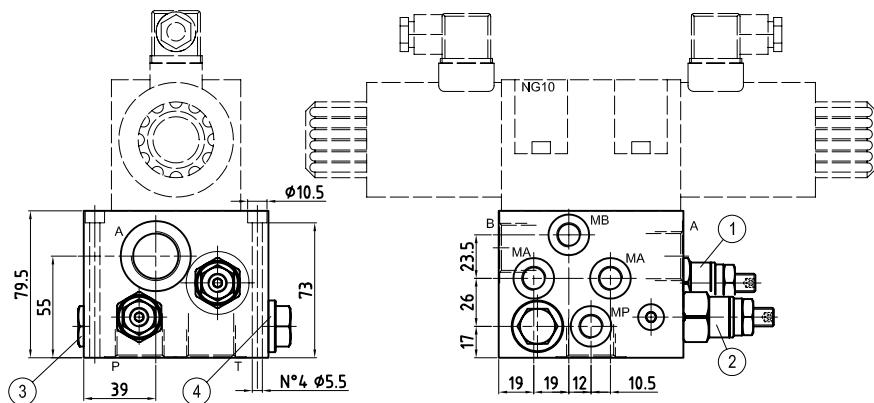
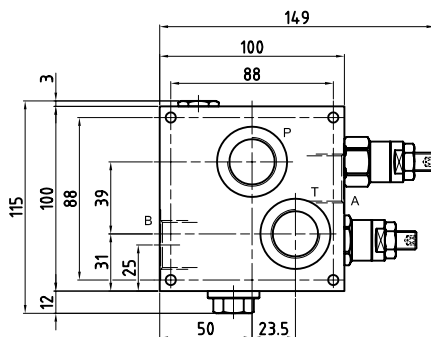

ORDERING CODE - ARTIKELNUMMER

41329

400

Valve/Ventil 1 Adj. range/Regelbereich	std setting Standardeinst.	Pressure increase MPa/turn Drucksteigerung MPa je Schraubendrehung	Valve/Ventil 1 Setting/Einstellung	Valve/Ventil 2 Adj. range/Regelbereich	std setting Standardeinst.	Pressure increase MPa/turn Drucksteigerung MPa je Schraubendrehung	Valve/Ventil 2 Setting/Einstellung
2 5-21 MPa	10 MPa	2.8	000 standard setting Standardeinstellung upon request - auf Anfrage	2 5-21 MPa	20 MPa	2.8	000 standard setting Standardeinstellung upon request - auf Anfrage
3 10-35 MPa	20 MPa	6.6	075 7.5 MPa	3 10-35 MPa	35 MPa	6.6	075 7.5 MPa
		 MPa			 MPa

GEM-06-PB-RIG

TECHNICAL DATA
TECHNISCHE ANGABEN

Max operating pressure Maximaler Betriebsdruck	35 Mpa 5076 psi
Max flow Volumenstrom	30 l/min 7.9 gpm
Temperature range Betriebstemperatur	-20°/80°C
Filtration Filtergrad	25µ
Weight Gewicht	2.0 kg
Material	Zincoated steel Verzinkter Stahl
Flangeable Flanschbar	ISO 4401-03-02-0-05 (CETOP 4.2-4-03-350)

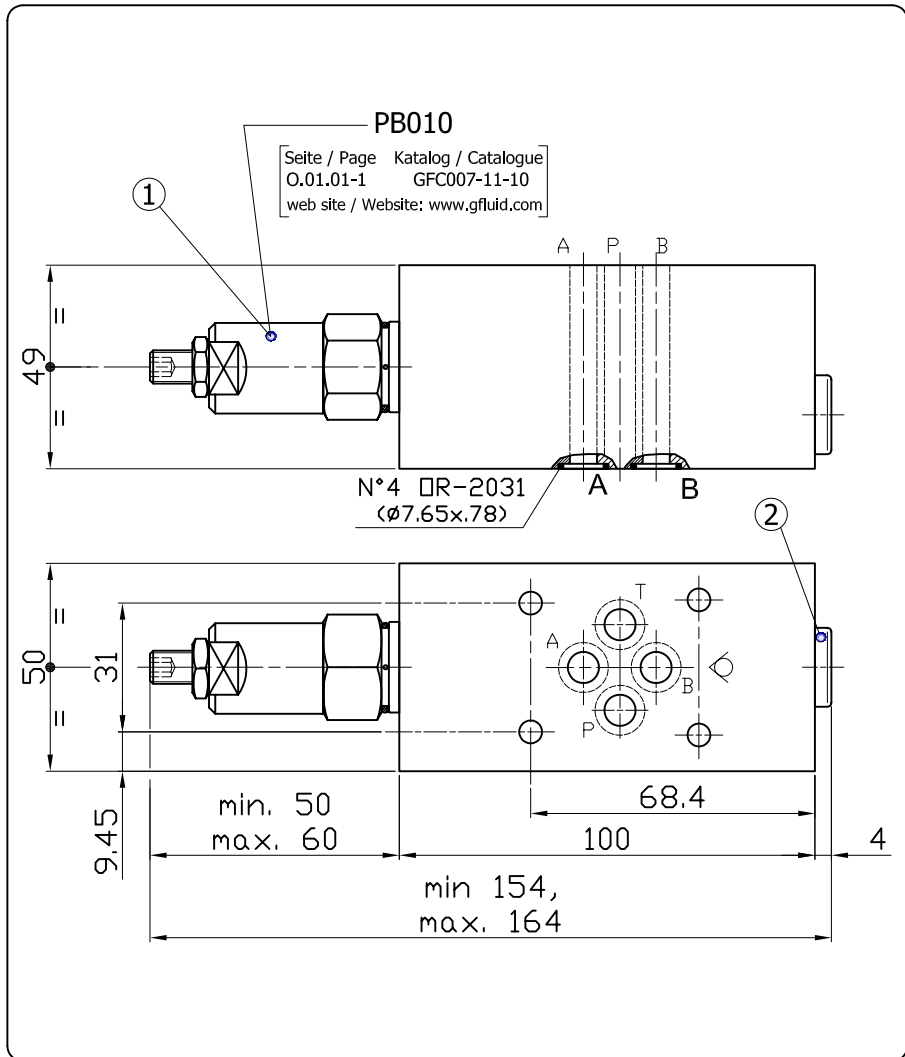
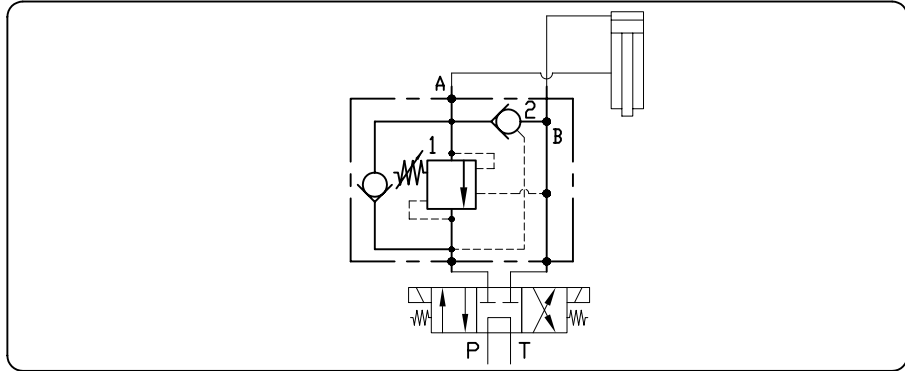

ORDERING INSTRUCTIONS - BESTELLANLEITUNG

41 23 90 11 1

-



-

00

Adjustment range
 Regelbereich
 4 | 10-35 MPa

GEM-06-E-0_08S

TECHNICAL DATA
TECHNISCHE ANGABEN

Max operating pressure Maximaler Betriebsdruck	35 Mpa 5076 psi
Max flow Volumenstrom	40 l/min 10.6 gpm
Temperature range Betriebstemperatur	-20°/80°C
Filtration Filtergrad	25μ
Weight Gewicht	1.5 kg
Material	Zincoated steel Verzinkter Stahl
Flangeable Flanschbar	ISO 4401-03-02-0-05 (CETOP 4.2-4-03-350)

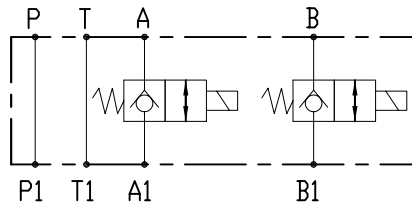
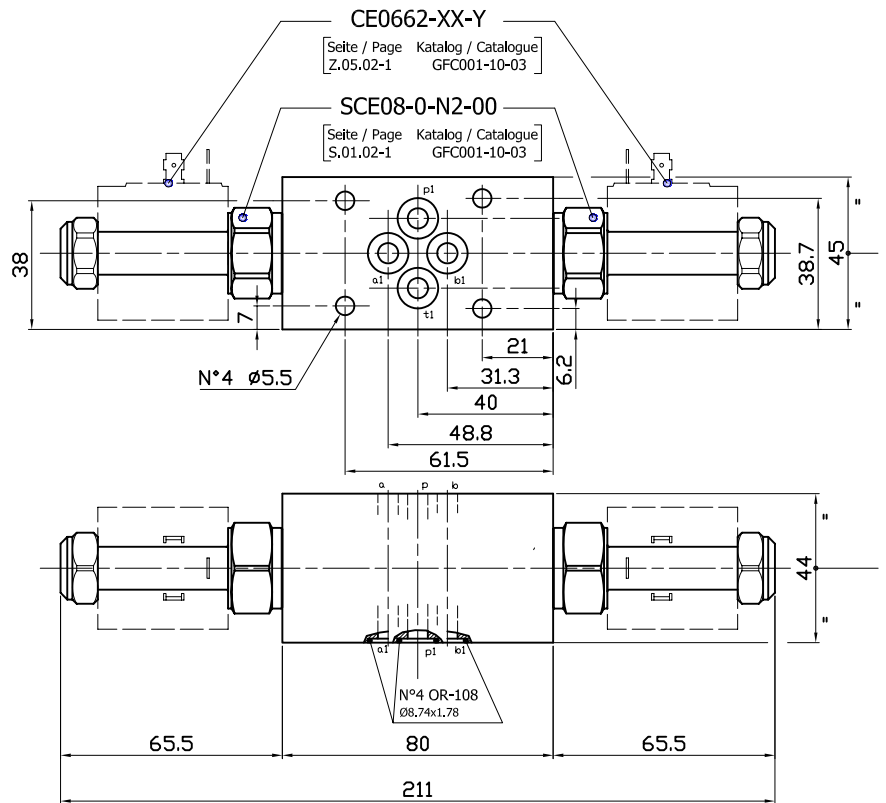
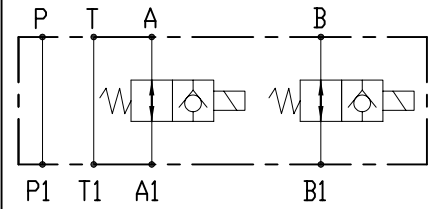
05 GEM-06-E-0508S

06 GEM-06-E-0608S

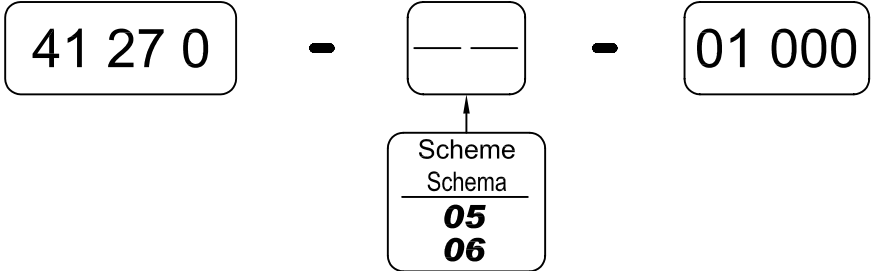
ORDERING INSTRUCTIONS - BESTELLANLEITUNG

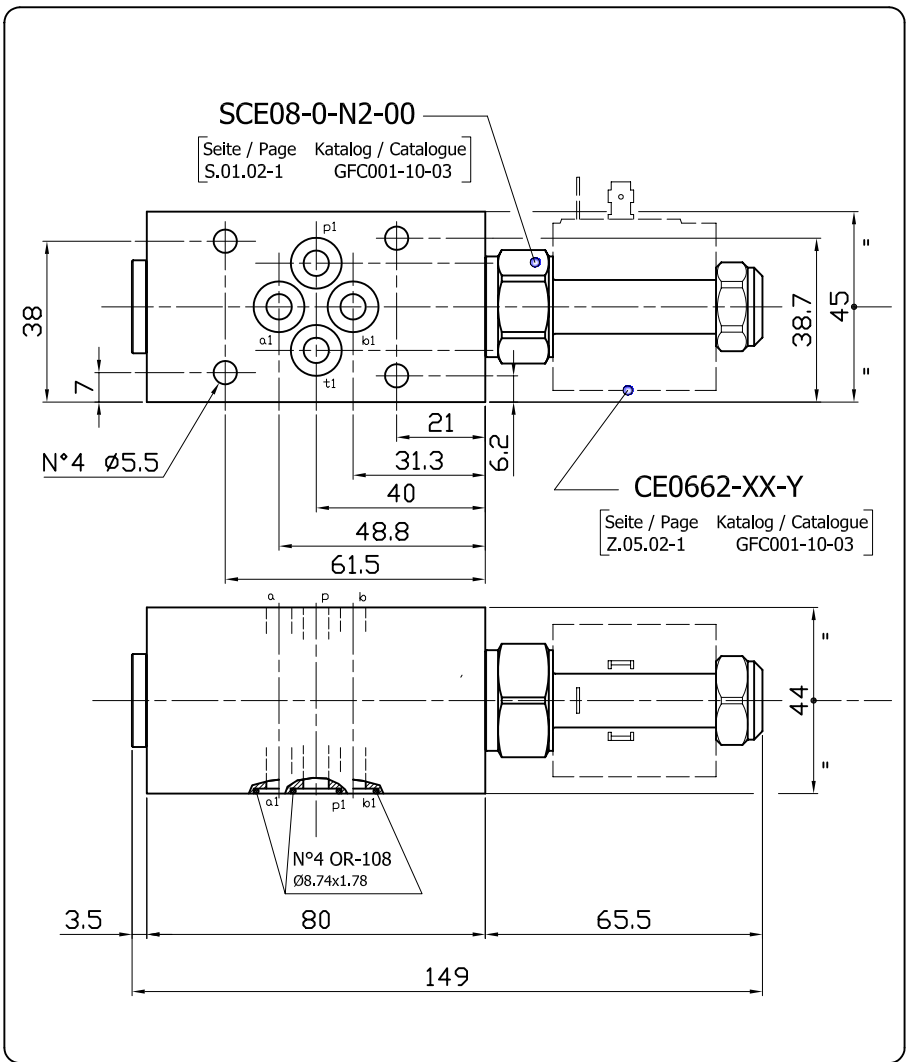
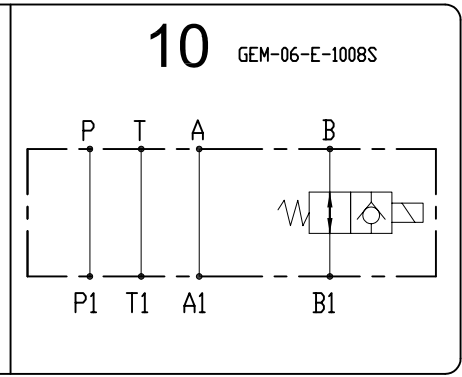
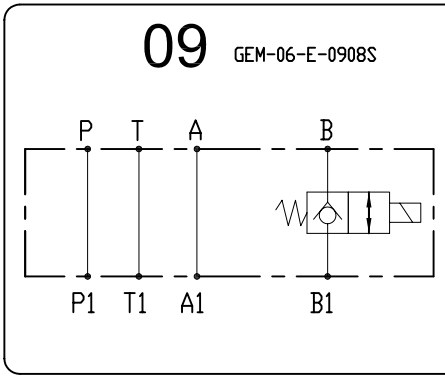

GEM-06-E-__08S

TECHNICAL DATA TECHNISCHE ANGABEN	
Max operating pressure Maximaler Betriebsdruck	35 Mpa 5076 psi
Max flow Volumenstrom	40 l/min 10.6 gpm
Temperature range Betriebstemperatur	-20°/80°C
Filtration Filtergrad	25μ
Weight Gewicht	1.4 kg
Material	Zincoated steel Verzinkter Stahl
Flangeable Flanschbar	ISO 4401-03-02-0-05 (CETOP 4.2-4-03-350)



ORDERING INSTRUCTIONS - BESTELLANLEITUNG

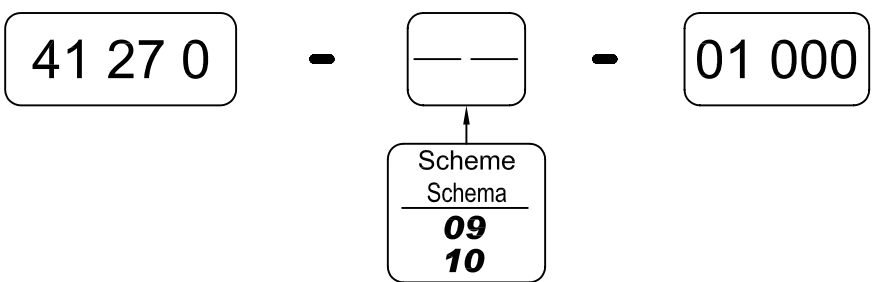

GEM-06P-N -R -

TECHNICAL DATA TECHNISCHE ANGABEN

Max operating pressure Maximaler Betriebsdruck	25 MPa-3626 psi (Alloy/Aluminium) 35 MPa-5076 psi (Zincoated Steel/Verzink. Stahl)
Max flow Volumenstrom	30 l/min 7.9 gpm
Temperature range Betriebstemperatur	-20°/80°C
Filtration Filtergrad	25µ
Flangeable Flanschbar	ISO 4401-03-02-0-05 (CETOP 4.2-4-03-320)

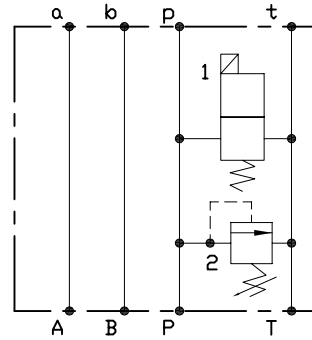

1 Solenoid Valve/Magnetventile

Without override/Keine Notbetätigung

01: SCE08-O-N2-00



11: SAE08-O-N2-00

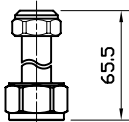

Manual screw-override/Notbetätigung mit Schraube

02: SCE08-S-N2-00

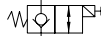

12: SAE08-S-N2-00

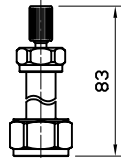

2 Relief Valve/Druckbegrenzungsventil

leakproof socket screw
lecköfrefreie Regulierungsschraube

01: PM208-_-000-X-N-00

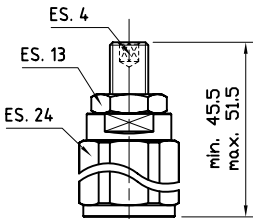

handknob and locknut
Handrad und Muttere

02: PM208-_-000-V-N-00

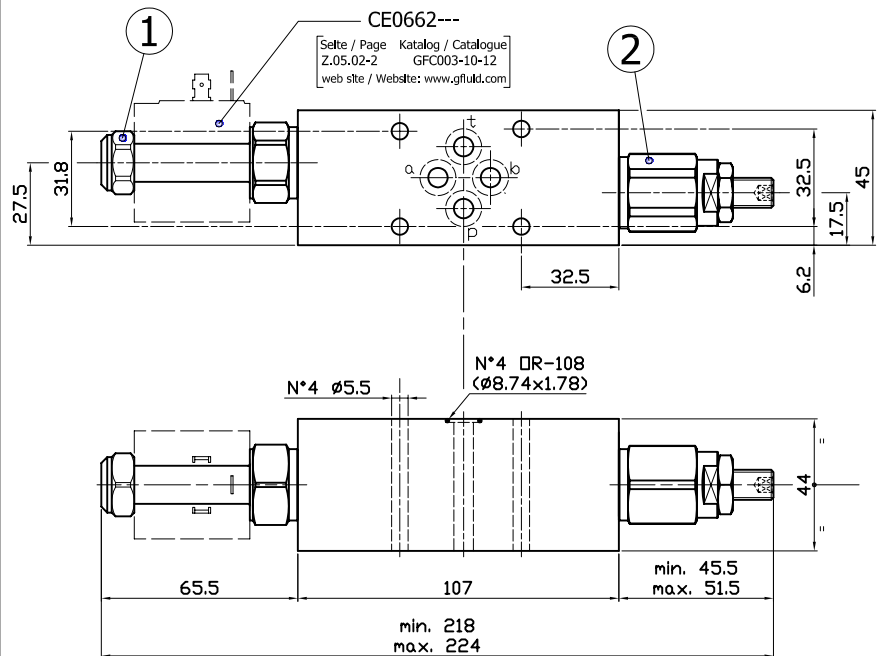
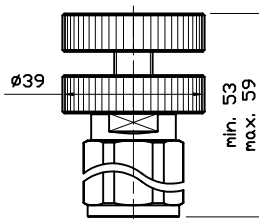

ORDERING INSTRUCTIONS - BESTELLANLEITUNG

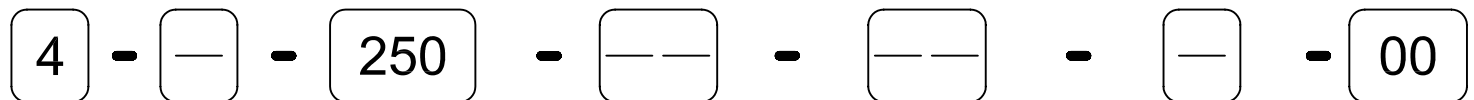

	Material	Weight
	Material	Gewicht
0	Alloy/Aluminium	0.7 kg
1	Zincoated steel Verzinkter Stahl	1.7 kg

Solenoid Valve Magnetventile
01
02
11
12

Relief Valve Druckbegrenzungsventil
01
02

Adjustment range Regelbereich	
1	1-6 MPa
2	5-20 MPa
3	20-35 MPa

GEM-ES-45-S

**TECHNICAL DATA
 TECHNISCHE ANGABEN**

Max operating pressure Maximaler Betriebsdruck	35 Mpa 5076 psi
Max flow Volumenstrom	80 l/min 21.1 gpm
Temperature range Betriebstemperatur	-20°/80°C
Filtration Filtergrad	25µ
Weight Gewicht	2.1 kg
Material	Zincoated steel Verzinkter Stahl
Flangeable Flanschbar	ISO 4401-05-04-0-94 (CETOP 4.2-4-05-320)

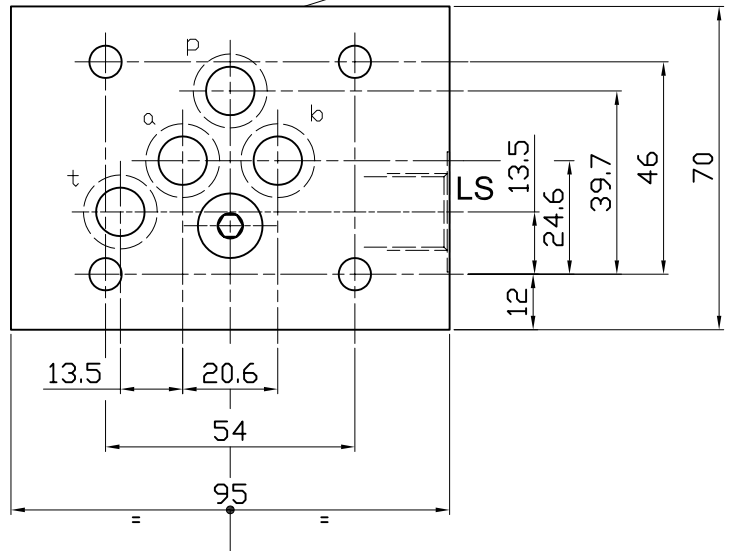
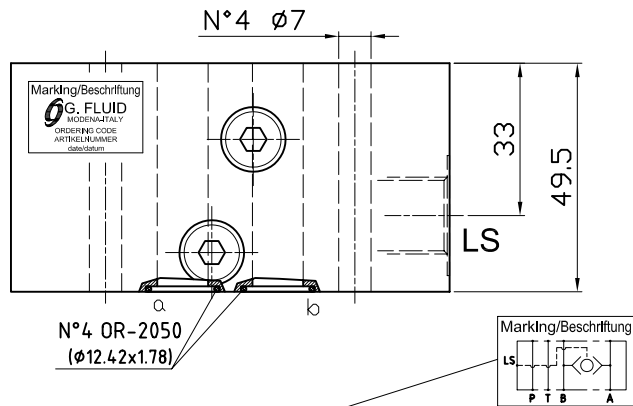
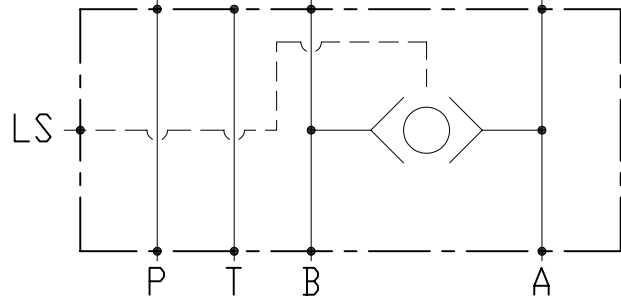

Diagram/Diagramm

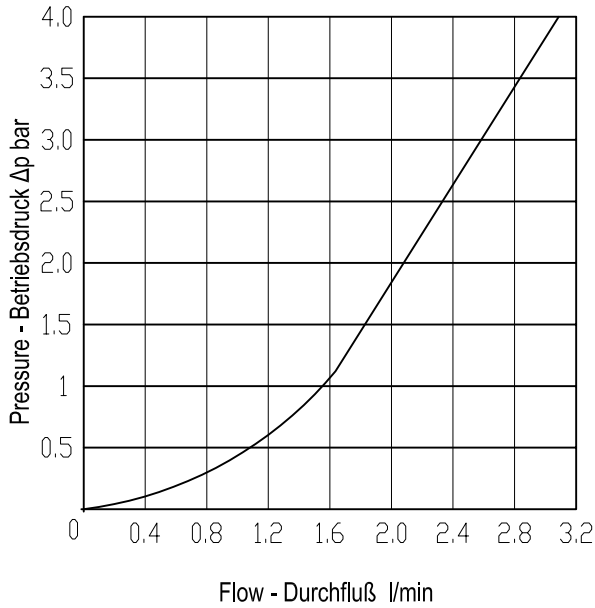

ORDERING CODE - ARTIKELNUMMER
413450021 0

GEM-VUST-06-CSE

TECHNICAL DATA TECHNISCHE ANGABEN

Max operating pressure Maximaler Betriebsdruck	25 Mpa 3626 psi
Max flow Volumenstrom	40 l/min 10.6 gpm
Temperature range Betriebstemperatur	-20°/80°C
Filtration Filtergrad	25µ
Weight Gewicht	0.6 kg
Material	Alloy Aluminium
Flangeable Flanschbar	ISO 4401-03-02-0-05 (CETOP 4.2-4-03-350)

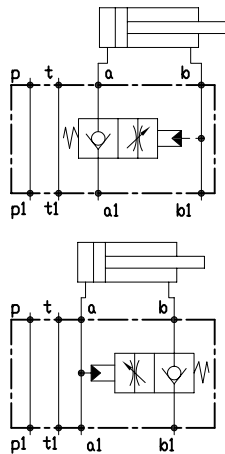
APPLICATION/ANWENDUNG



Diagram/Diagramm

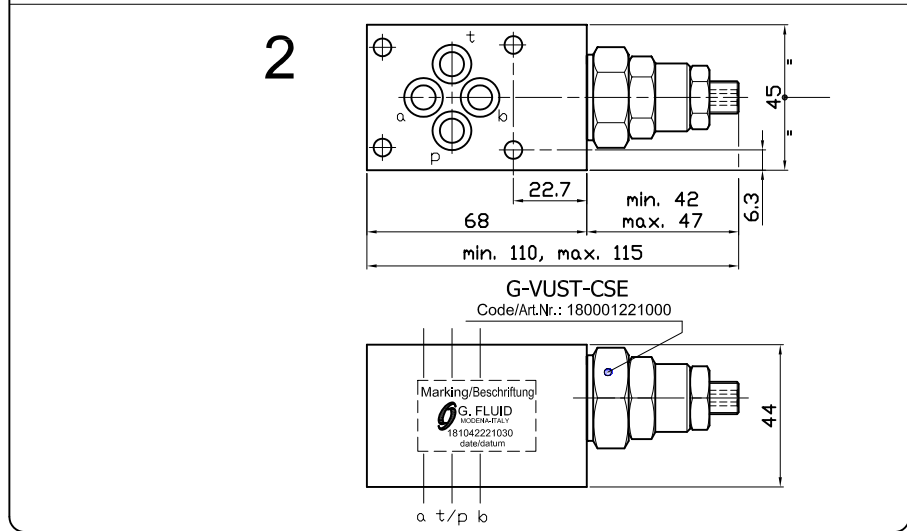
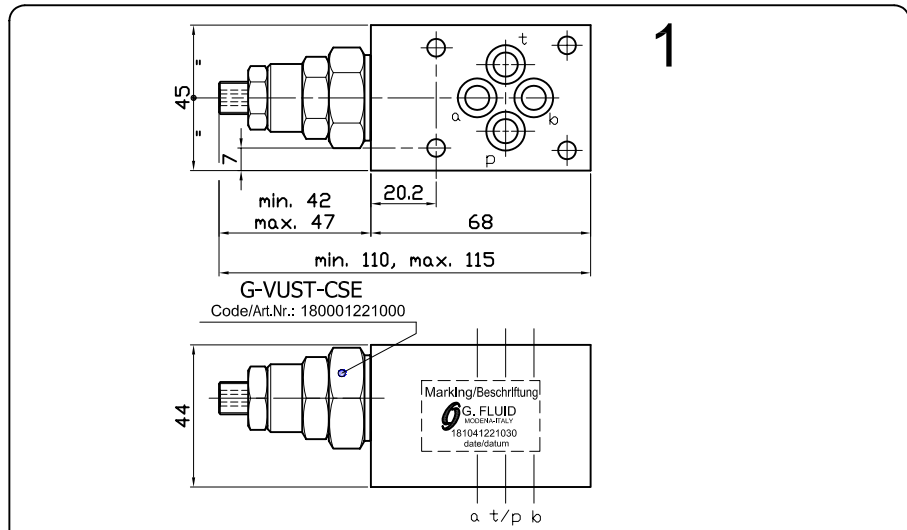
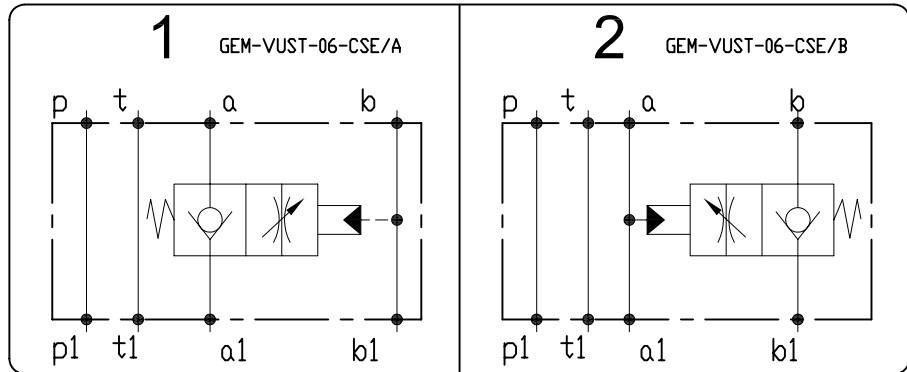
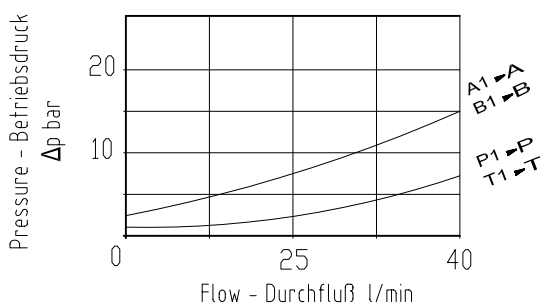

ORDERING INSTRUCTIONS - BESTELLANLEITUNG

18 10 4 - - 22 10 - - 0

Scheme Schema	Pilot ratio Versteuerverhältnis
1	3 3:1
2	

GEM-VUST-06-DE

TECHNICAL DATA TECHNISCHE ANGABEN

Max operating pressure Maximaler Betriebsdruck	25 Mpa 3626 psi
Max flow Volumenstrom	40 l/min 10.6 gpm
Temperature range Betriebstemperatur	-20°/80°C
Filtration Filtergrad	25µ
Weight Gewicht	1 kg
Material Material	Alloy Aluminium
Flangeable Flanschbar	ISO 4401-03-02-0-05 (CETOP 4.2-4-03-350)

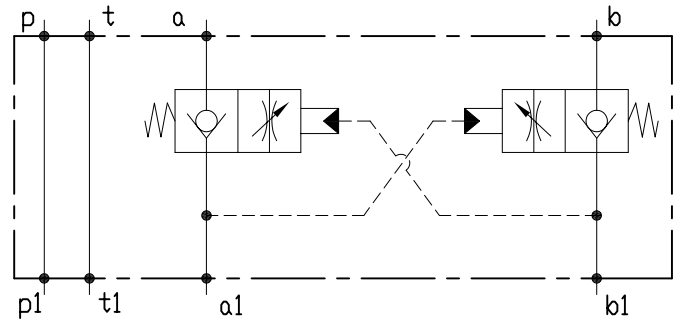

APPLICATION/ANWENDUNG

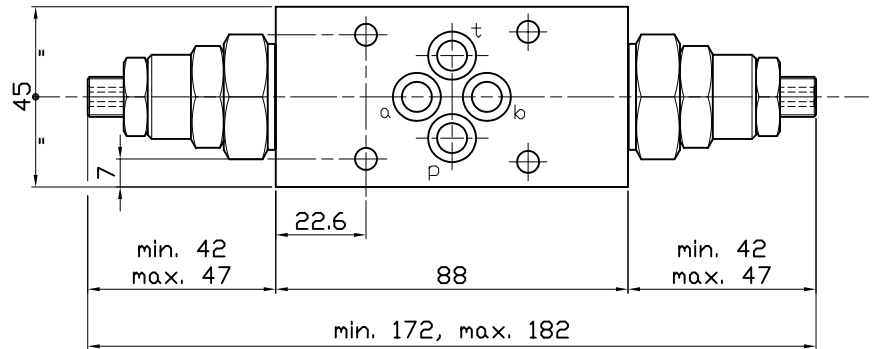
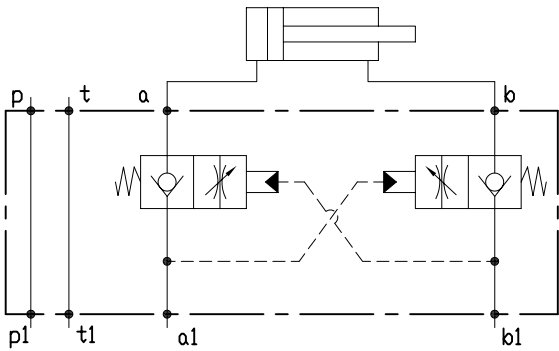

N°2 G-VUST-C
Code/Art.Nr.: 180000221000

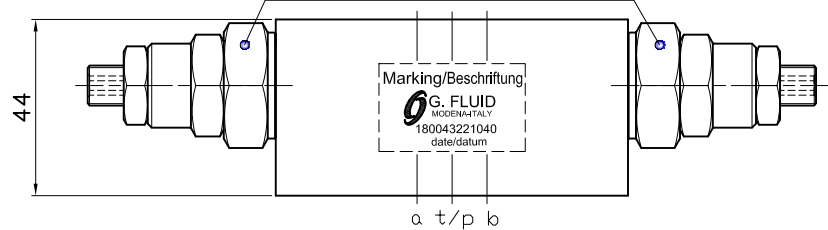

Diagram/Diagramm

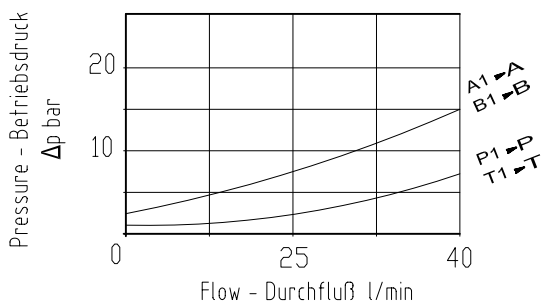

ORDERING INSTRUCTIONS - BESTELLANLEITUNG

18 00 43 22 10 - - 0

Pilot ratio Versteuerverhältnis	
4	4:1

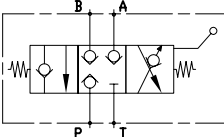
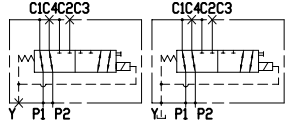
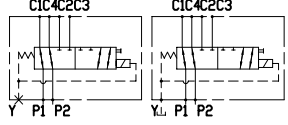
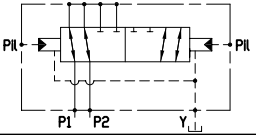
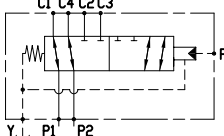
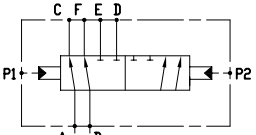
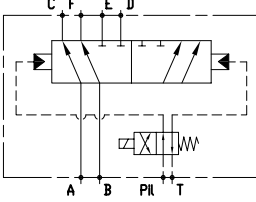
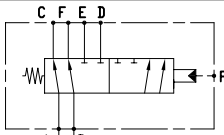
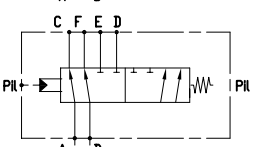
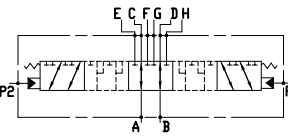
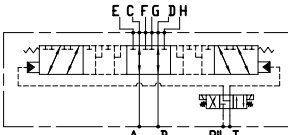
Schema Schema	Description Bezeichnung	max flow max Durchfluß	max pressure max Arbeitsdruck	page Seite
	GVS-DSL43-023-BRN	30 l/min-7.9 gpm	50 MPa-7111 psi	10.001.01
	GVS-DSL43-090-BRN	120 l/min-31.7 gpm	30 MPa-4266 psi	10.001.02
	GED-ED3-80-34	80 l/min 21.1 gpm	35 MPa 5076 psi	10.001.51
	GED-ED6-80-34	80 l/min 21.1 gpm	35 MPa 5076 psi	10.002.10
	GED-ED6-80-34-PIDE	80 l/min 21.1 gpm	35 MPa 5076 psi	10.002.20
	GED-ED6-80-34-PIRM	80 l/min 21.1 gpm	35 MPa 5076 psi	10.002.30
	GED-ED6-300-1-PIDE	300 l/min 79.2 gpm	42 MPa 5974 psi	10.002.100
	GED-ED6-300-1	300 l/min 79.2 gpm	42 MPa 5974 psi	10.002.120
	GED-ED6-300-1-PIRM	300 l/min 79.2 gpm	42 MPa 5974 psi	10.002.130
	GED-ED6-300-1-PIRM-S			
	GED-ED8-250-1	250 l/min 66 gpm	35 MPa 5076 psi	10.002.210
	GED-ED8-250-1-__	250 l/min 66 gpm	35 MPa 5076 psi	10.002.220

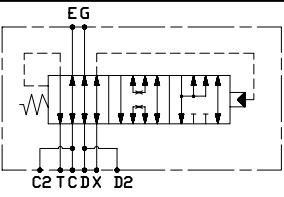
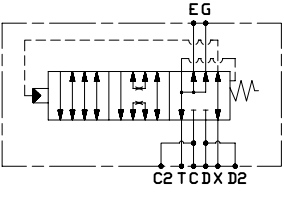
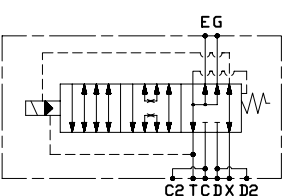
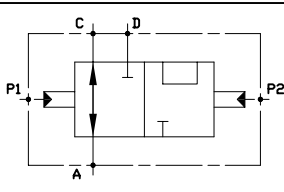
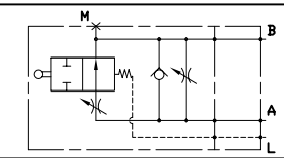
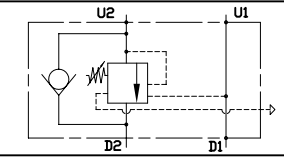
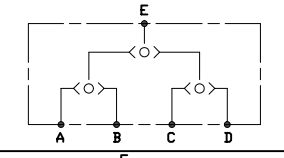
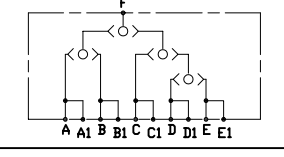
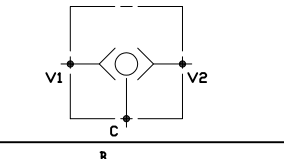
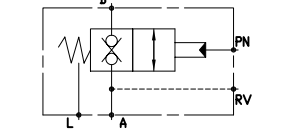
Scheme Schema	Description Bezeichnung	max flow max Durchfluß	max pressure max Arbeitsdruck	page Seite
	<p>GED-ED5-FW-300-34-7640 GED-ED5-FW-300-114-7640</p>			<p>10.002.310 10.002.320</p>
	<p>GED-ED5-FW-300-34-7550 GED-ED5-FW-300-114-7550</p>	<p>300 l/min 79.2 gpm</p>	<p>42 MPa 5974 psi</p>	<p>10.002.310 10.002.320</p>
	<p>GED-ED5-FW-300-34-155 GED-ED5-FW-300-114-155</p>			<p>10.002.310 10.002.320</p>
	<p>GED-D3-300-1</p>	<p>300 l/min 79.2 gpm</p>	<p>42 MPa 5974 psi</p>	<p>10.002.410</p>
	<p>GVS-TRT-G911-059-ANT</p>	<p>250 l/min 66 gpm</p>	<p>31 MPa 4400 psi</p>	<p>10.003.01</p>
	<p>GVZ-PB020-007-CR</p>	<p>60 l/min 18.5 gpm</p>	<p>35 MPa 5076 psi</p>	<p>10.010.01</p>
	<p>GV-3SEL-04-14-HC</p>	<p>5 l/min 1.3 gpm</p>	<p>25 MPa 3626 psi</p>	<p>10.020.01</p>
	<p>GV-4SEL-04-11P-14-HC</p>	<p>5 l/min 1.3 gpm</p>	<p>25 MPa 3626 psi</p>	<p>10.020.02</p>
	<p>GV-SEL-14</p>	<p>50 l/min 13.2 gpm</p>	<p>35 MPa 5076 psi</p>	<p>10.020.11</p>
	<p>GVS-SB010-PIRM-042-NEU</p>	<p>10 l/min 2.6 gpm</p>	<p>42 MPa 5974 psi</p>	<p>10.030.11</p>

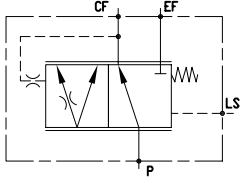
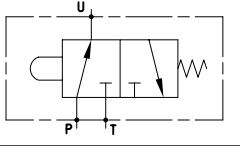
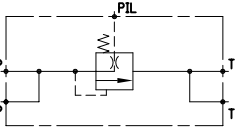
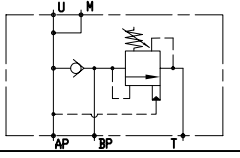
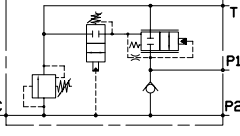
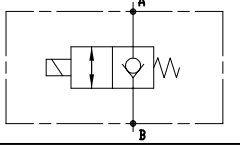
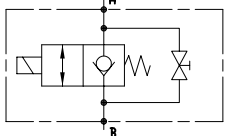
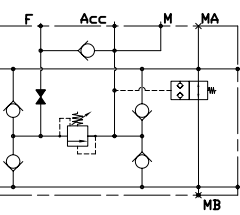
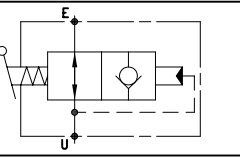
Schema Schema	Description Bezeichnung	max flow max Durchfluß	max pressure max Arbeitsdruck	page Seite
	GRF-VPS-12 GRF-VPS-12F	40 l/min 10.6 gpm	35 MPa 5076 psi	10.031.11 10.031.21
	GVD-3V-SCS-18	3 l/min 0.79 gpm	35 MPa 5076 psi	10.035.11
	GVR-CP-C115G-12-18-TMA	40 l/min 10.6 gpm	25 MPa 3626 psi	10.035.12
	GVS-EPD-038-PSC	70 l/min 18.5 gpm	35 MPa 5076 psi	10.040.10
	GVEP-2P-34	30 l/min 7.9 gpm	35 MPa 5076 psi	10.080.10
	GVE-SC-BF-38	30 l/min 7.9 gpm	25 MPa 3626 psi	10.090.03
	GVE-SC-BF-EM-38 GVE-SC-BF-EM-12	30 l/min 7.9 gpm	25 MPa 3626 psi	10.090.23 10.090.26
	GVS-STA-38-005-04-KR	40 l/min 10.6 gpm	35 MPa 5076 psi	10.100.05
	VCP-F-06-12	30 l/min 7.9 gpm	25 MPa 3626 psi	10.100.10

GVS-DSL43-023-BRN

TECHNICAL DATA TECHNISCHE ANGABEN

Max operating pressure Maximaler Betriebsdruck	50 MPa 7111 psi
Max flow Volumenstrom	30 l/min 7.9 gpm
Temperature range Betriebstemperatur	-20°/80°C
Filtration Filtergrad	40µ
Weight/Material Gewicht/Material	4.7 kg
Material Material	Zinc coated Steel Verzinkter Stahl

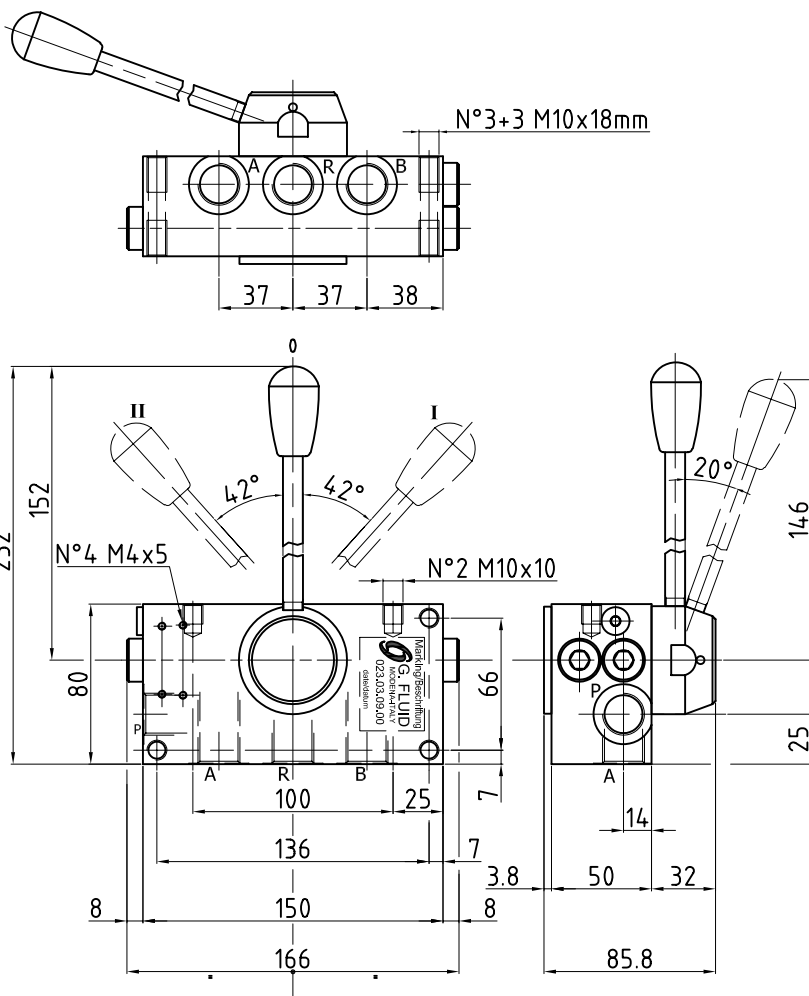
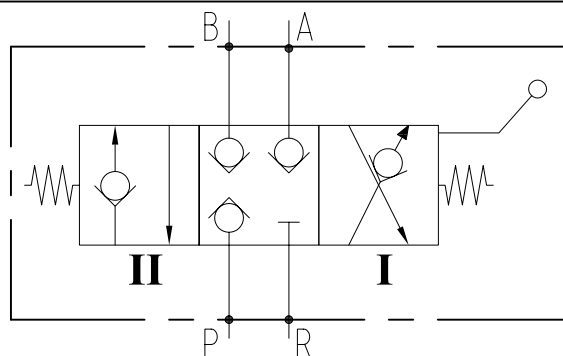

PORT SIZE GEWINDE

A, B, R, P	G 1/2"

ORDERING INSTRUCTIONS - BESTELLANLEITUNG

023.03.09.00

**TECHNICAL DATA
TECHNISCHE ANGABEN**

Max operating pressure Maximaler Betriebsdruck	30 MPa 4266 psi
Max flow Volumenstrom	120 l/min 31.7 gpm
Temperature range Betriebstemperatur	-20°/80°C
Filtration Filtergrad	40µ
Weight/Material Gewicht/Material	18 kg
Material Material	Zinc coated Steel Verzinkter Stahl

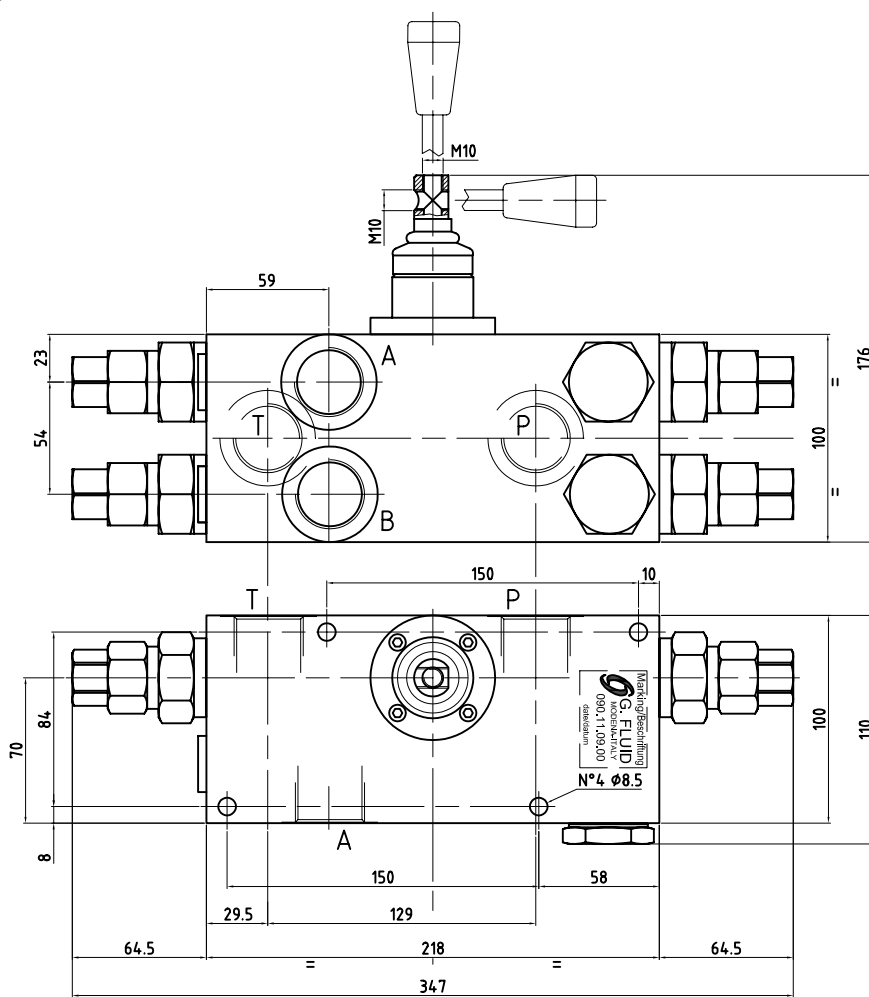
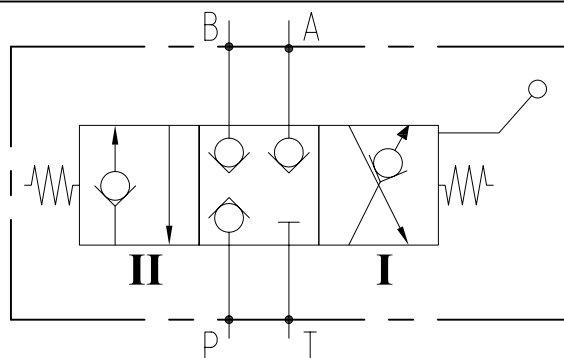

**PORT SIZE
GEWINDE**

A, B, T, P	G 1"

ORDERING INSTRUCTIONS - BESTELLANLEITUNG
090.11.09.00

TECHNICAL DATA
TECHNISCHE ANGABEN

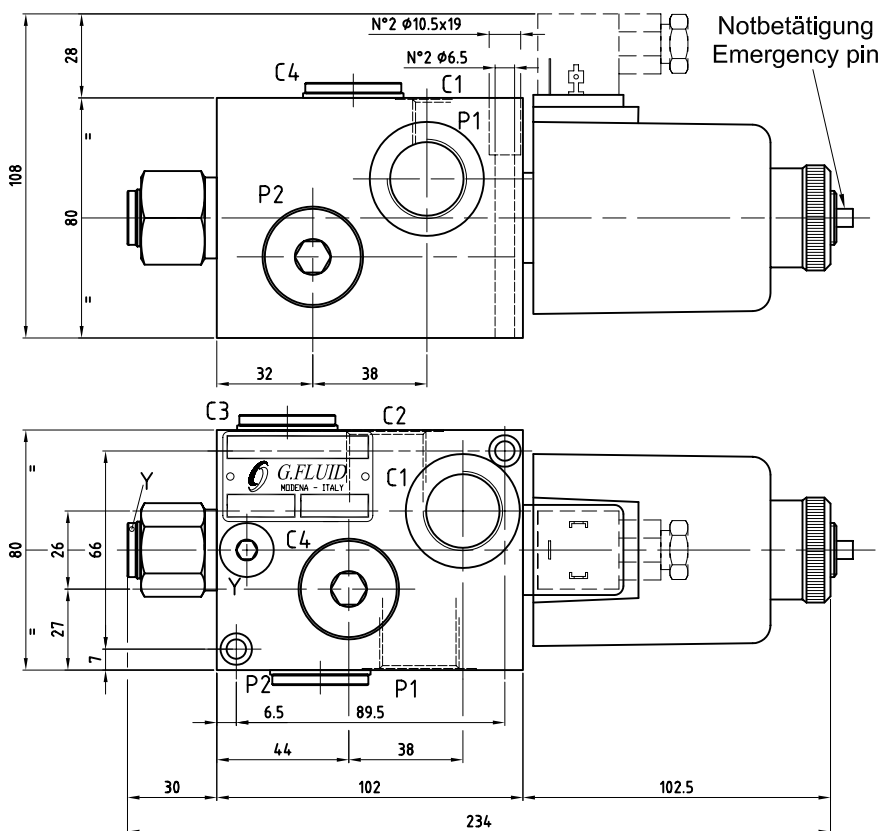
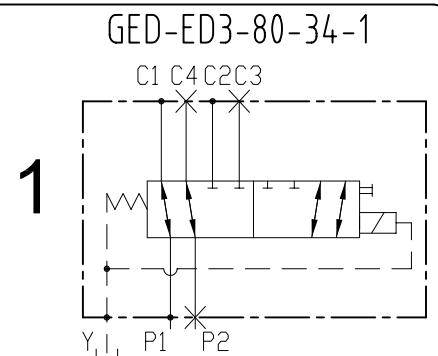
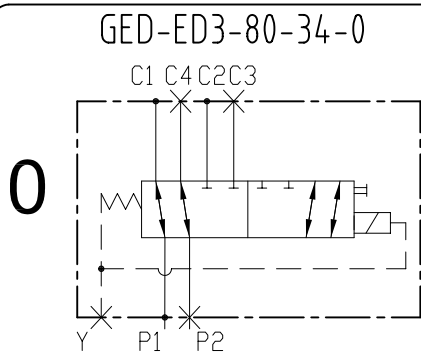
Max operating pressure Maximaler Betriebsdruck	35 MPa 5076 psi
Max flow Volumenstrom	80 l/min 21.1 gpm
Temperature range Betriebstemperatur	-20°/80°C
Filtration Filtergrad	40μ
Weight Gewicht	5.1 kg
Material Material	Zincoated Steel Verzinkter Stahl

ORDERING CODE - ARTIKELNUMMER
1643331 0 0

0	Scheme Schema	1	Voltage Spannung	4	Port size/Gewinde
1	GED-ED3-80-34-0	2	12 VDC		P1, P2, C1, C2, C3, C4 Y
	GED-ED3-80-34-1		24 VDC		G 3/4" G 1/8"

TECHNICAL DATA
TECHNISCHE ANGABEN

Max operating pressure Maximaler Betriebsdruck	35 MPa 5076 psi
Max flow Volumenstrom	80 l/min 21.1 gpm
Temperature range Betriebstemperatur	-20°/80°C
Filtration Filtergrad	40μ
Weight Gewicht	5.1 kg
Material Material	Zincoated Steel Verzinkter Stahl

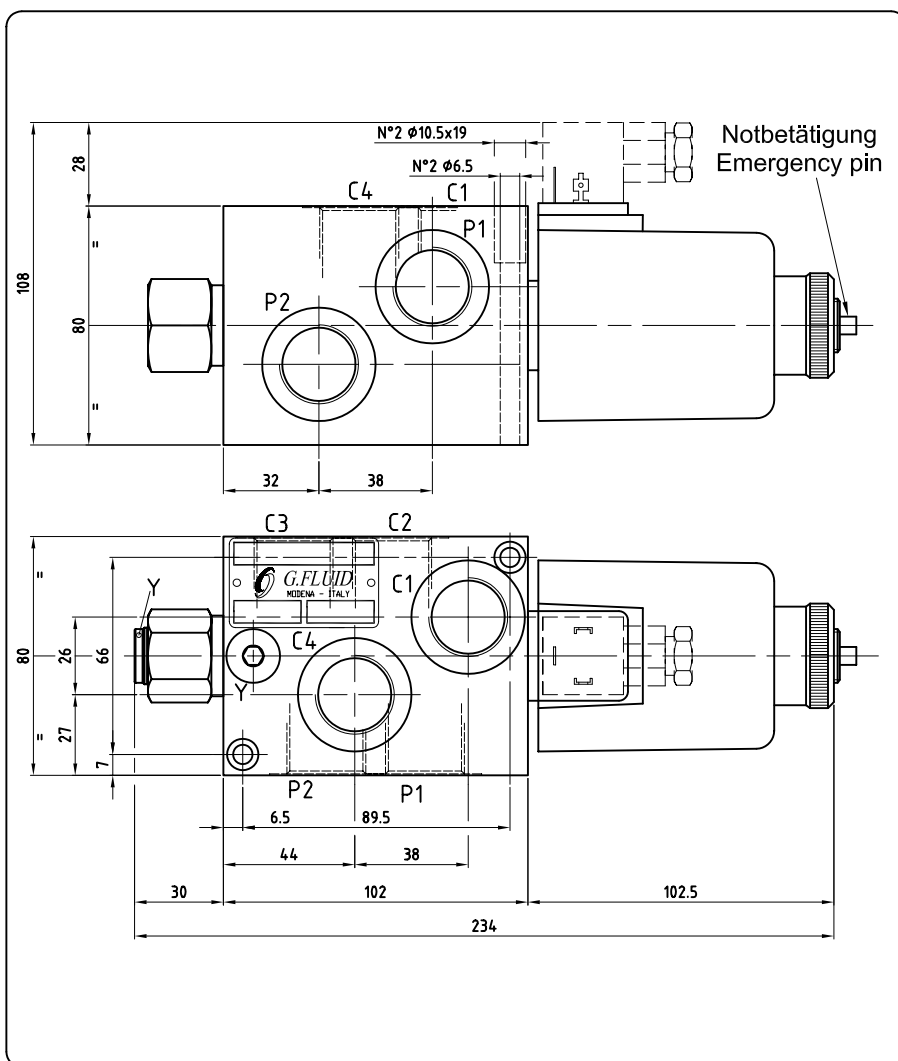
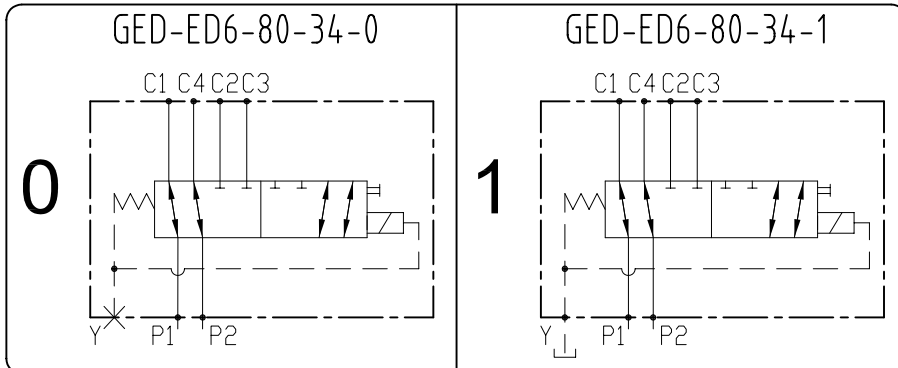

ORDERING INSTRUCTIONS - BESTELLANLEITUNG
16 43 36 1 - - - 0 - - 0

Scheme Schema		Voltage Spannung		Port size/Gewinde P1, P2, C1, C2, C3, C4 Y	
0	GED-ED6-80-34-0	1	12 VDC	4	G 3/4" G 1/8"
1	GED-ED6-80-34-1	2	24 VDC		

GED-ED6-80-34-PIDE

TECHNICAL DATA
TECHNISCHE ANGABEN

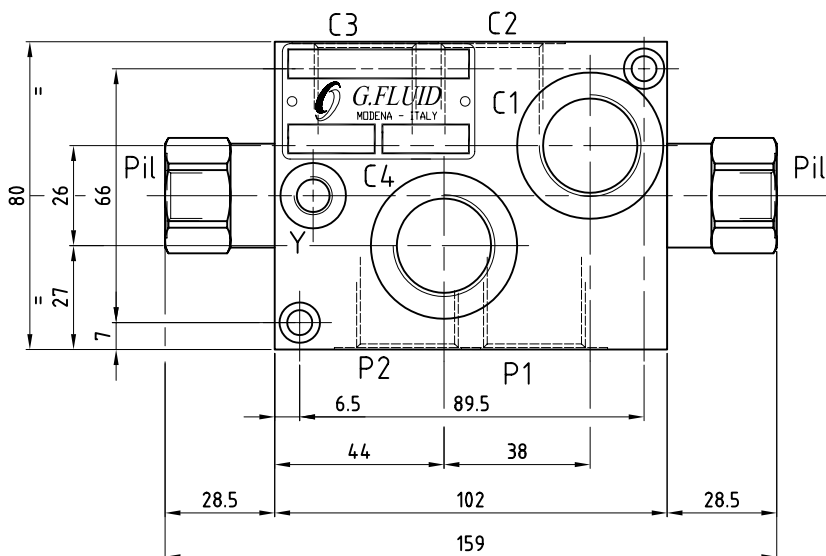
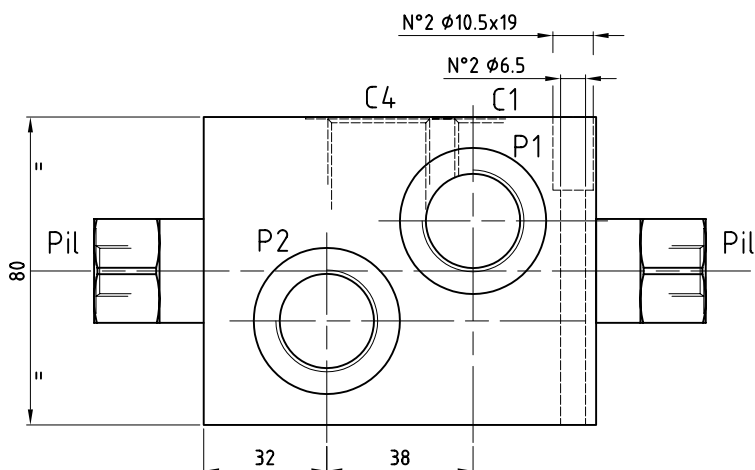
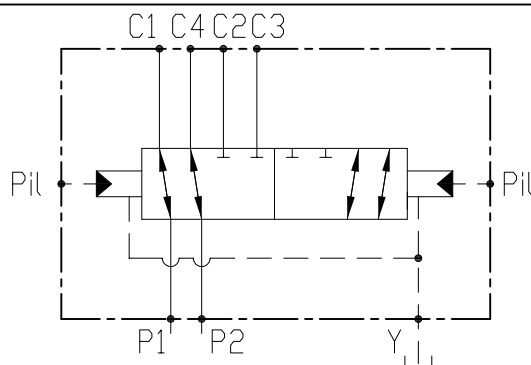
Max operating pressure Maximaler Betriebsdruck	35 MPa 5076 psi
Max flow Volumenstrom	80 l/min 21.1 gpm
Pilot pressure on P11 Steuerdruck in P11	min. 2 MPa - 290 psi max. 5 MPa - 725 psi
Temperature range Betriebstemperatur	-20°/80°C
Filtration Filtergrad	40μ
Material/Material Weight/Gewicht	Zincoated Steel/Verzinkter Stahl 5.1 kg



ORDERING INSTRUCTIONS - BESTELLANLEITUNG
16 43 56 11 00 - - 0

Port size/Gewinde			
P1, P2, C1, C2, C3, C4	P11	Y	
4	G 3/4"	G 1/4"	G 1/8"

GED-ED6-80-34-PIRM

TECHNICAL DATA
TECHNISCHE ANGABEN

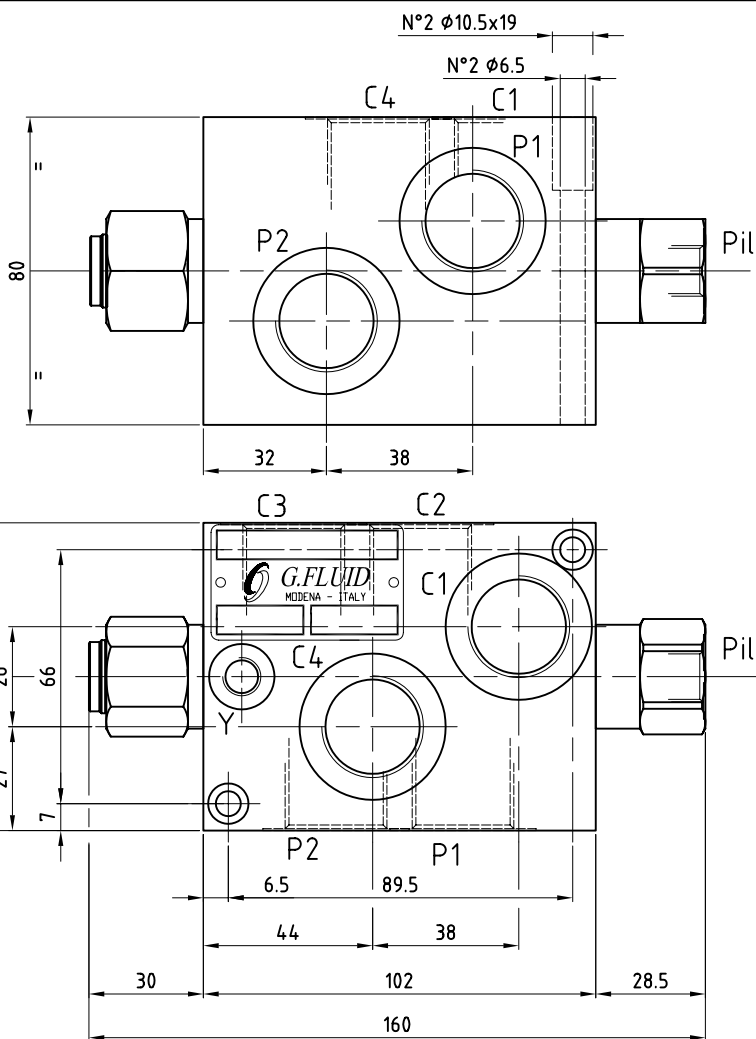
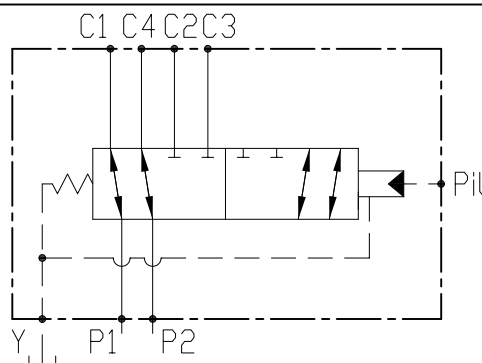
Max operating pressure Maximaler Betriebsdruck	35 MPa 5076 psi
Max flow Volumenstrom	80 l/min 21.1 gpm
Pilot pressure on P11 Steuerdruck in P11	min. 2 MPa - 290 psi max. 5 MPa - 725 psi
Temperature range Betriebstemperatur	-20°/80°C
Filtration Filtergrad	40µ
Material/Material Weight/Gewicht	Zincoated Steel/Verzinkter Stahl 5.1 kg

ORDERING INSTRUCTIONS - BESTELLANLEITUNG
16 43 76 11 00 - - 0

Port size/Gewinde			
P1, P2, C1, C2, C3, C4	P11	Y	
4	G 3/4"	G 1/4"	G 1/8"

GED-ED6-300-1-PIDE

TECHNICAL DATA
TECHNISCHE ANGABEN

Max operating pressure Maximaler Betriebsdruck	42 MPa 5974 psi
Max flow Volumenstrom	300 l/min 79.2 gpm
Pilot pressure on P1-P2 Steuerdruck in P1-P2	min. 2 MPa - 290 psi max. 5 MPa - 725 psi
Temperature range Betriebstemperatur	-20°/80°C
Filtration Filtergrad	40µ
Material/Material Weigth/Gewicht	Zincoated Steel/Verzinkter Stahl 12 kg

APPLICATION/ANWENDUNG

6 way 2 position directional valve hydraulically piloted, suitable to control 2 motors for high flow and high pressure. Compact construction and simple mounting.
 6/2 - Wegeventil, das hydraulisch gesteuert wird und für die Kontrolle von 2 Hydraulikmotoren mit hohen Durchflussraten und hohen Drücken geeignet ist.
 Kompakte Konstruktion und einfache Montage

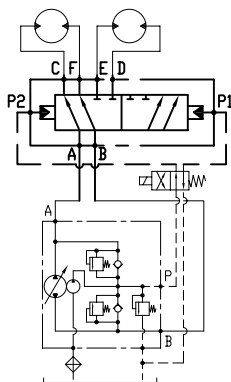
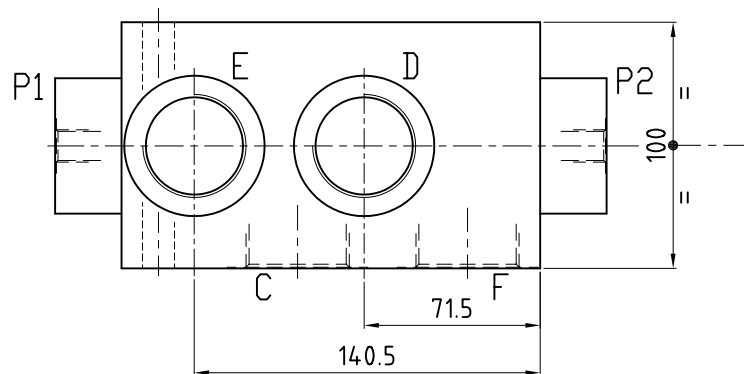
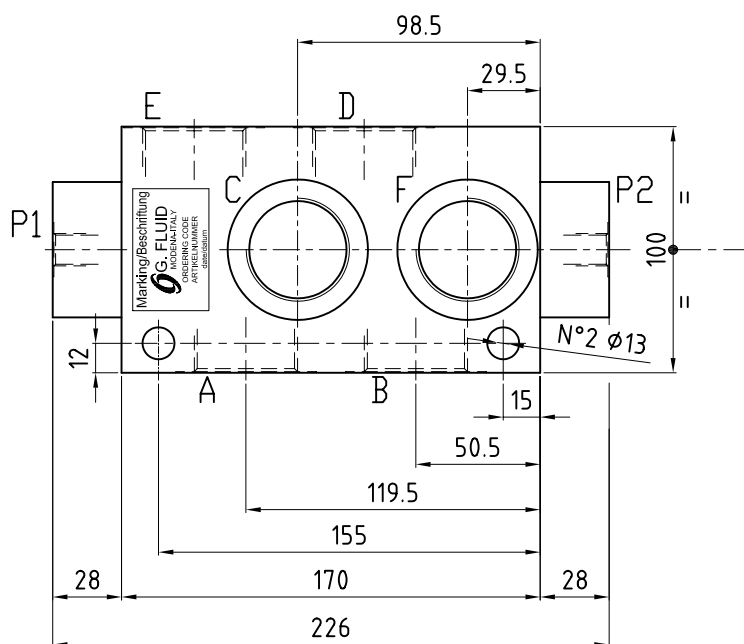
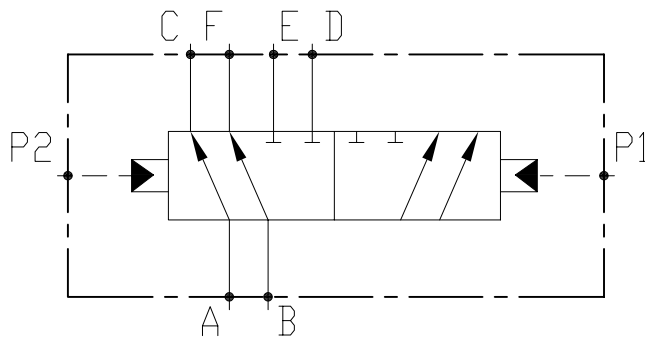
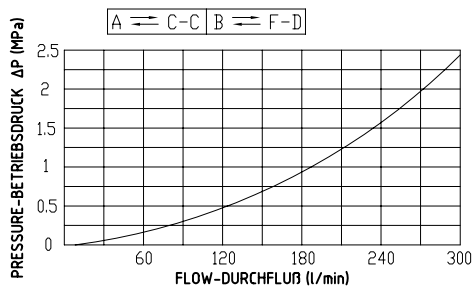
Diagram/Diagramm

ORDERING CODE - ARTIKELNUMMER
1646561000 0

6	Port size/Gewinde	
	A, B, C, D, E, F	Pil, T
	G 1"1/4	G 1/4"

TECHNICAL DATA
TECHNISCHE ANGABEN

Max operating pressure Maximaler Betriebsdruck	42 MPa 5974 psi
Max flow Volumenstrom	300 l/min 79.2 gpm
Pilot pressure Steuerdruck	min. 2 MPa - 290 psi max. 5 MPa - 725 psi
Temperature range Betriebstemperatur	-20°/80°C
Filtration Filtergrad	40µ
Material/Material Weigth/Gewicht	Zincoated Steel/Verzinkter Stahl 17 kg

APPLICATION/ANWENDUNG

6 way 2 position directional valve hydraulically piloted, suitable to control 2 motors for high flow and high pressure. Compact construction and simple mounting.
 6/2 - Wegeventil, das hydraulisch gesteuert wird und für die Kontrolle von 2 Hydraulikmotoren mit hohen Durchflussraten und hohen Drücken geeignet ist.
 Kompakte Konstruktion und einfache Montage

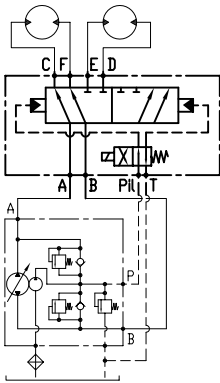
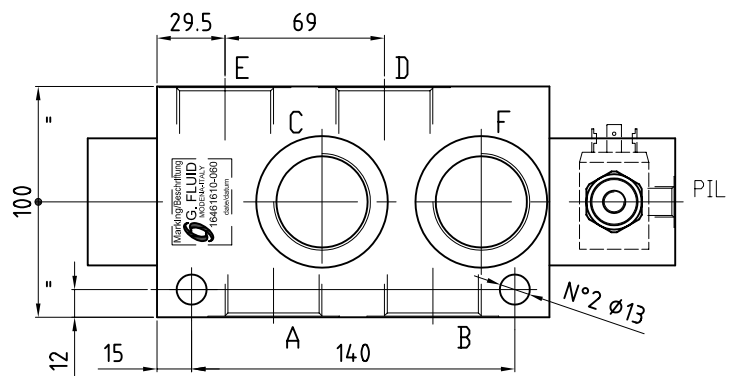
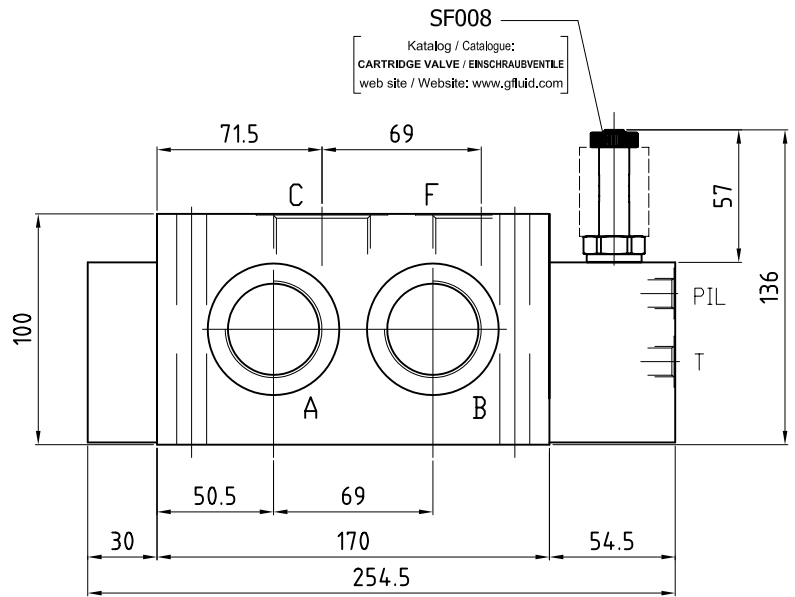
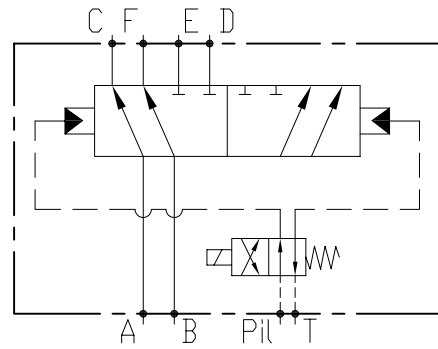
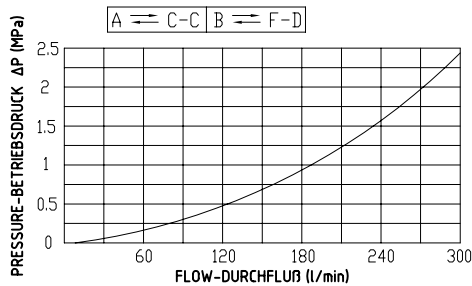
Diagram/Diagramm

ORDERING INSTRUCTIONS - BESTELLANLEITUNG
16 46 16 10 - - 0 - - 0

Voltage Spannung		Port size/Gewinde	
1	12 VDC	A, B, C, D, E, F	Pil, T
2	24 VDC	6	G 1"1/4 G 1/4"

GED-ED6-300-1-PIRM

TECHNICAL DATA
TECHNISCHE ANGABEN

Max operating pressure Maximaler Betriebsdruck	42 MPa 5974 psi
Max flow Volumenstrom	300 l/min 79.2 gpm
Pilot pressure on Pil Steuerdruck in Pil	min. 2 MPa - 290 psi max. 5 MPa - 725 psi
Temperature range Betriebstemperatur	-20°/80°C
Filtration Filtergrad	40µ
Material/Material Weigth/Gewicht	Zincoated Steel/Verzinkter Stahl 14 kg

APPLICATION/ANWENDUNG

6 way 2 position directional valve hydraulically piloted, suitable to control 2 motors for high flow and high pressure. Compact construction and simple mounting.
 6/2 - Wegeventil, das hydraulisch gesteuert wird und für die Kontrolle von 2 Hydraulikmotoren mit hohen Durchflussraten und hohen Drücken geeignet ist.
 Kompakte Konstruktion und einfache Montage

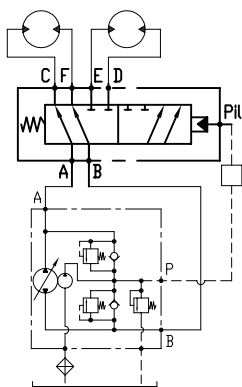
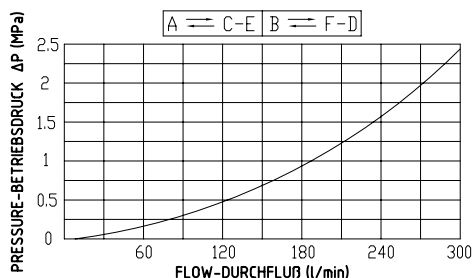
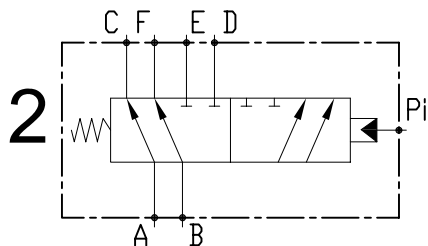
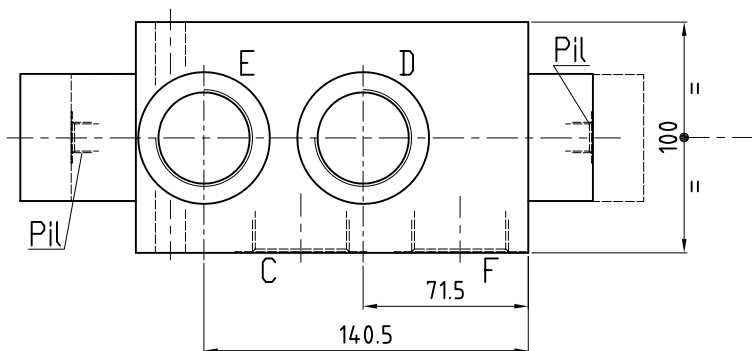
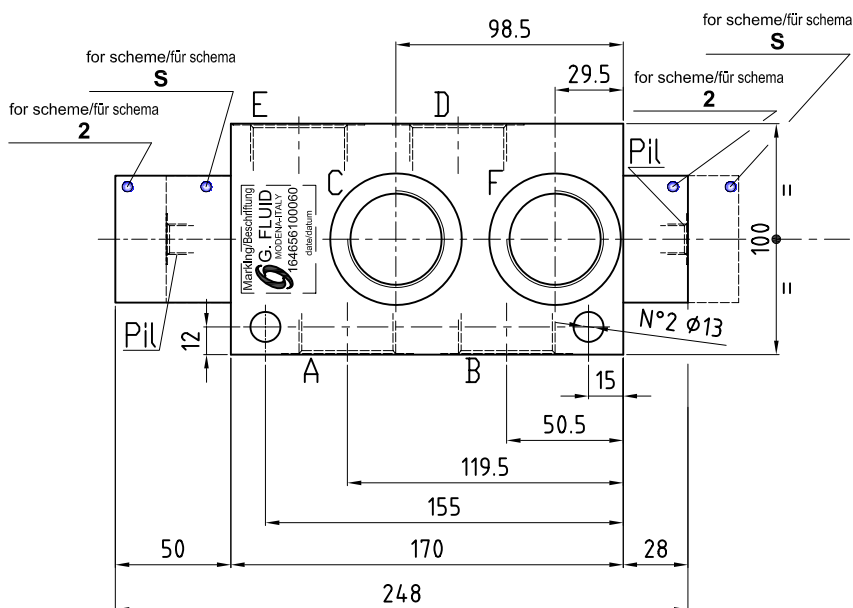
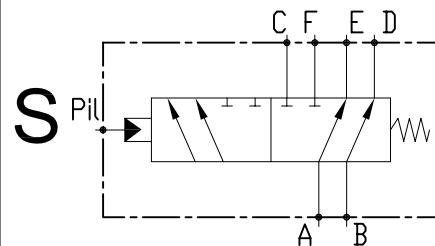
Diagram/Diagramm

GED-ED6-300-1-PIRM

GED-ED6-300-1-PIRM-S

ORDERING INSTRUCTIONS - BESTELLANLEITUNG
164676 000 0

	Scheme/Schema Description/Bezeichnung	Port size/Gewinde A, B, C, D, E, F Pil, T
2	GED-ED6-300-1-PIRM	G 1" 1/4 G 1/4
S	GED-ED6-300-1-PIRM-S	

TECHNICAL DATA
TECHNISCHE ANGABEN

Max operating pressure Maximaler Betriebsdruck	35 MPa 5076 psi
Max flow Volumenstrom	250 l/min 66 gpm
Pilot pressure on P1-P2 Steuerdruck in P1-P2	min. 1 MPa - 145 psi max. 2 MPa - 290 psi
Temperature range Betriebstemperatur	-20°/80°C
Filtration Filtergrad	40μ
Weight Gewicht	16.4 kg
Material	Zinc coated Steel Verzinkter Stahl

APPLICATION/ANWENDUNG

8 way 3 position directional valve hydraulically piloted, suitable to control 3 motors for high flow and high pressure. Compact construction and simple mounting.
 8/3 - Wegeventil, das hydraulisch gesteuert wird und für die Kontrolle von 2 Hydraulikmotoren mit hohen Durchflussraten und hohen Drücken geeignet ist.

Kompakte Konstruktion und einfache Montage

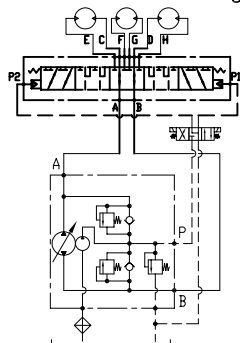
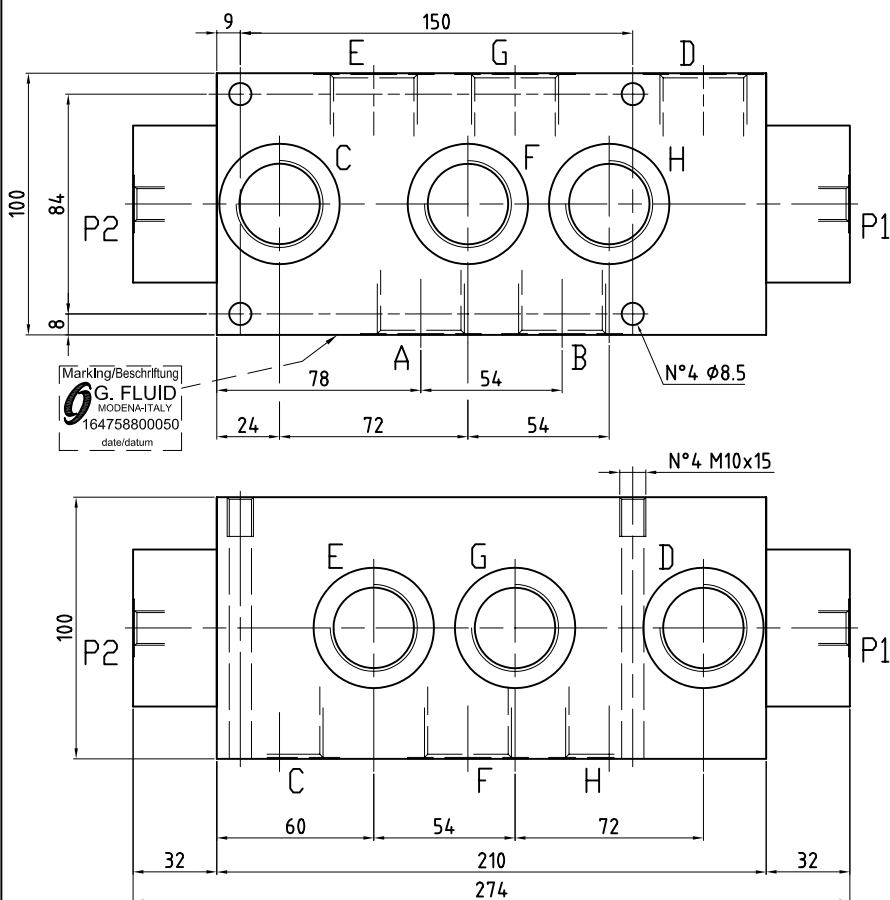
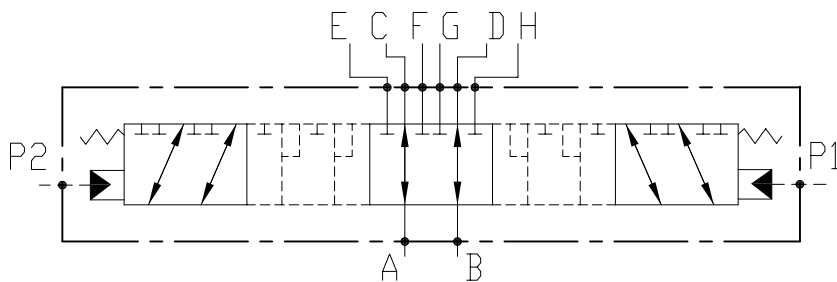
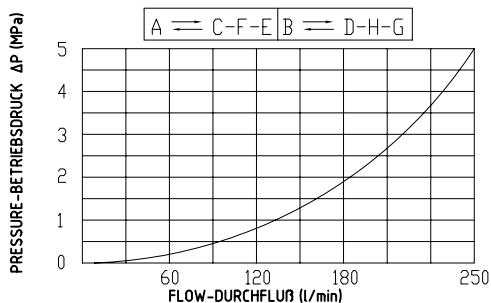
Diagram/Diagramm

ORDERING INSTRUCTIONS - BESTELLANLEITUNG
16 47 58 80 00 - - 0

Port size/Gewinde	
A, B, C, D, E, F, G, H	P1, P2
5 G 1"	G 1/4"

TECHNICAL DATA
TECHNISCHE ANGABEN

Max operating pressure Maximaler Betriebsdruck	35 MPa 5076 psi
Max flow Volumenstrom	250 l/min 66 gpm
Pilot pressure on P1-P2 Steuerdruck in P1-P2	min. 1 MPa - 145 psi max. 2 MPa - 290 psi
Temperature range Betriebstemperatur	-20°/80°C
Filtration Filtergrad	40µ
Weight Gewicht	16.4 kg
Material Material	Zinc coated Steel Verzinkter Stahl

APPLICATION/ANWENDUNG

8 way 3 position directional valve hydraulically piloted, suitable to control 3 motors for high flow and high pressure. Compact construction and simple mounting.
 8/3 - Wegeventil, das hydraulisch gesteuert wird und für die Kontrolle von 2 Hydraulikmotoren mit hohen Durchflussraten und hohen Drücken geeignet ist.
 Kompakte Konstruktion und einfache Montage

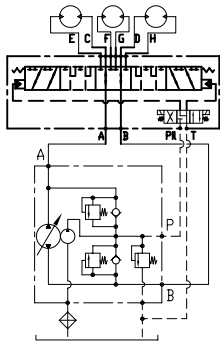
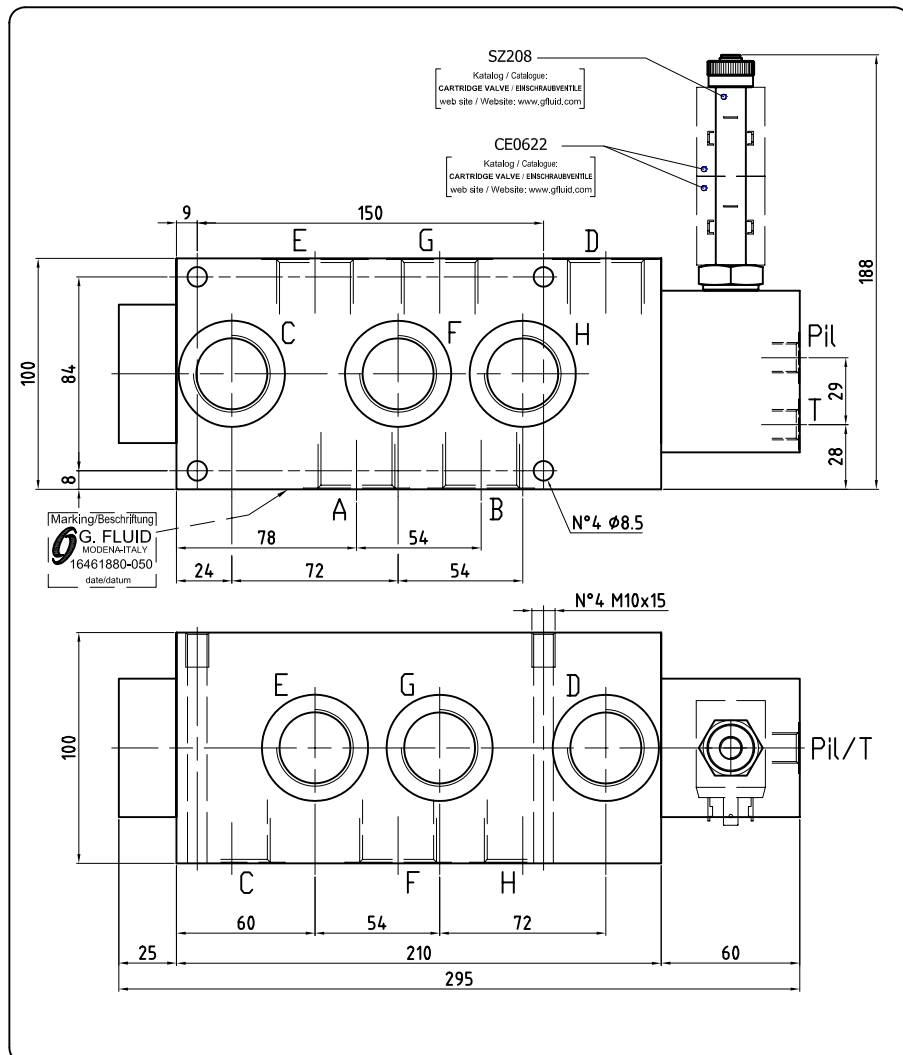
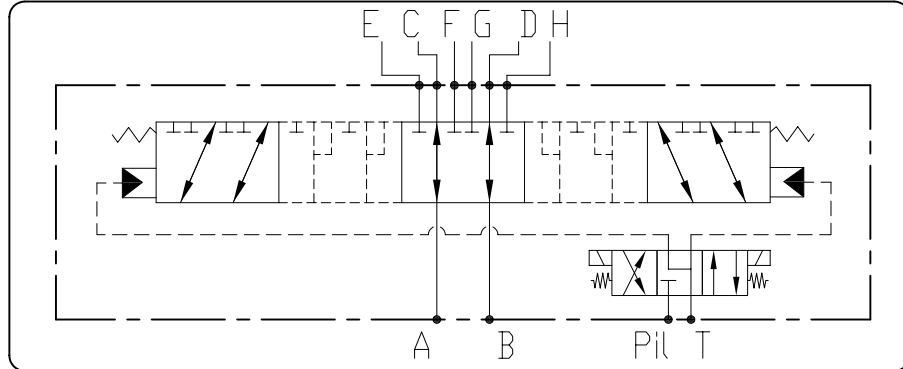
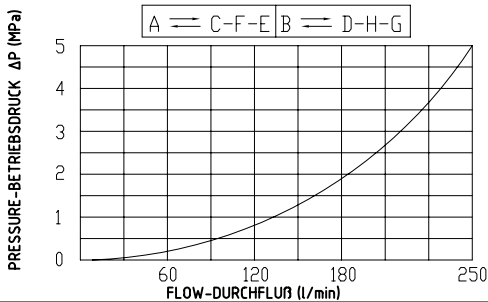
Diagram/Diagramm

ORDERING INSTRUCTIONS - BESTELLANLEITUNG
16 46 18 80 - 0 - 0

Voltage Spannung	Description Bezeichnung	Port size/Gewinde
1 12 VDC	GED-ED8-250-1-11	A, B, C, D, E, F, G, H PII, T
2 24 VDC	GED-ED8-250-1-12	5 G 1" G 1/4"

GED-ED5-FW-300-34

TECHNICAL DATA
TECHNISCHE ANGABEN

Max operating pressure Maximaler Betriebsdruck	42 MPa 5974 psi
Max flow Volumenstrom	300 l/min 79.2 gpm
Pilot pressure Steuerdruck	min. 2 MPa - 290 psi max. 5 MPa - 725 psi
Temperature range Betriebstemperatur	-20°/80°C
Filtration Filtergrad	40µ
Material Material	Zincoated Steel Verzinkter Stahl

5 way 2 position directional valve hydraulically piloted for high flow and high pressure.

Compact construction and simple mounting.

5/2 - Wegeventil, das hydraulisch gesteuert wird mit hohen Durchflussraten und hohen Drücken geeignet ist.

Kompakte Kostruktion und einfache Montage

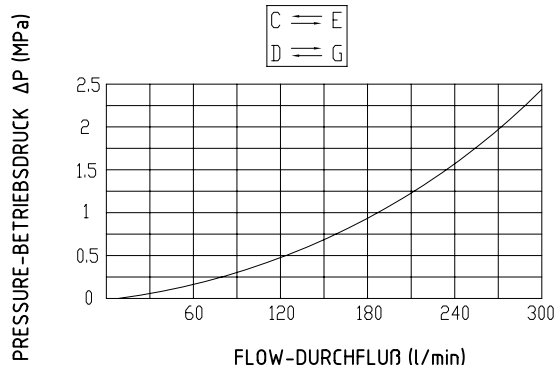
Diagram/Diagramm

PORT SIZE
GEWINDE

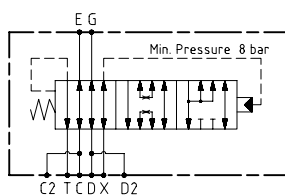
C, D, E, G	1" Sae 3000 psi
C2, D2, T	G 3/4"
X	G 1/4"

764 GED-ED5-FW-300-34-7640

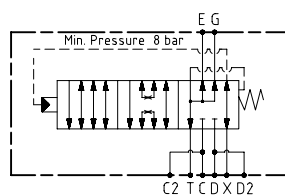
Weigth/Gewicht: 16.3 kg

755 GED-ED5-FW-300-34-7550

Weigth/Gewicht: 16.5 kg

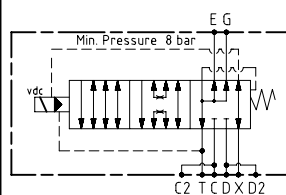
155 12V: GED-ED5-FW-300-34-1551
 24V: GED-ED5-FW-300-34-1552

Weigth/Gewicht: 16.7 kg

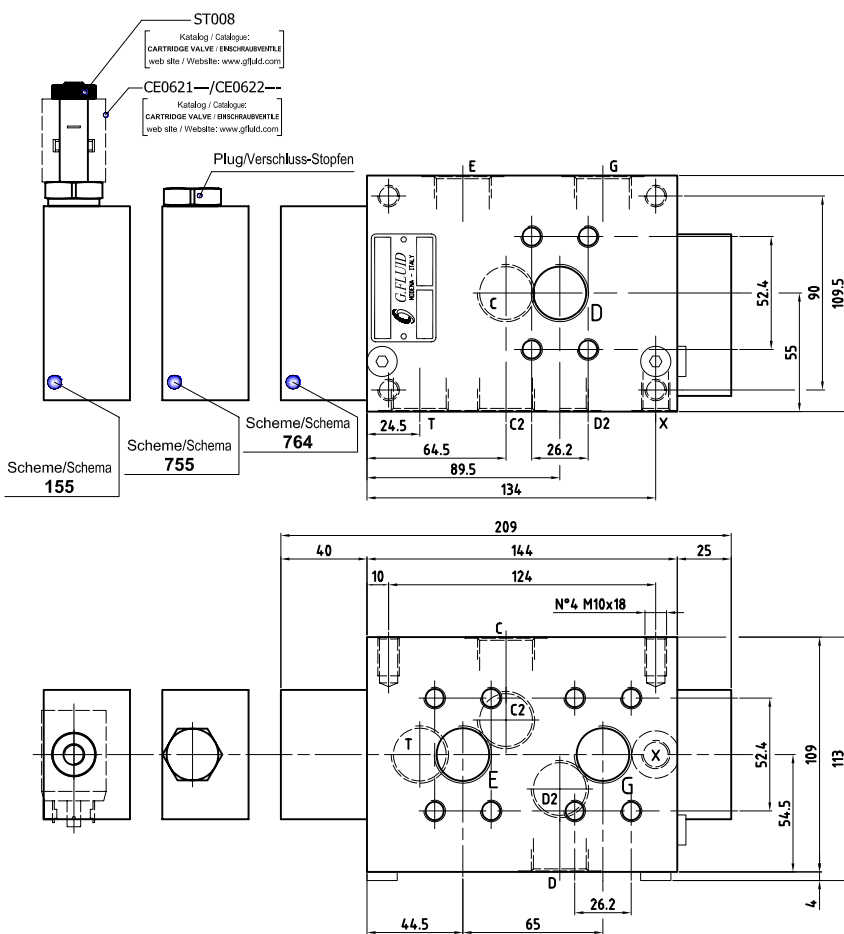
ORDERING CODE - ARTIKELNUMMER
1646 0 04

Scheme/Schema		Voltage/Spannung		Update/Aktualisierte Version	
764	GED-ED5-FW-300-34-7640	0	only scheme/nur Schema: 764/755	0	only scheme/nur Schema: 755/155
755	GED-ED5-FW-300-34-7550	1	12 VDC (only scheme/nur Schema: 155)	1	only scheme/nur Schema: 764
155	GED-ED5-FW-300-34-155_	2	24 VDC (only scheme/nur Schema: 155)		

GED-ED5-FW-300-114

TECHNICAL DATA
TECHNISCHE ANGABEN

Max operating pressure Maximaler Betriebsdruck	42 MPa 5974 psi
Max flow Volumenstrom	300 l/min 79.2 gpm
Pilot pressure Steuerdruck	min. 2 MPa - 290 psi max. 5 MPa - 725 psi
Temperature range Betriebstemperatur	-20°/80°C
Filtration Filtergrad	40µ
Material Material	Zincoated Steel Verzinkter Stahl

5 way 2 position directional valve hydraulically piloted for high flow and high pressure.

Compact construction and simple mounting.

5/2 - Wegeventil, das hydraulisch gesteuert wird mit hohen Durchflussraten und hohen Drücken geeignet ist.

Kompakte Kostruktion und einfache Montage

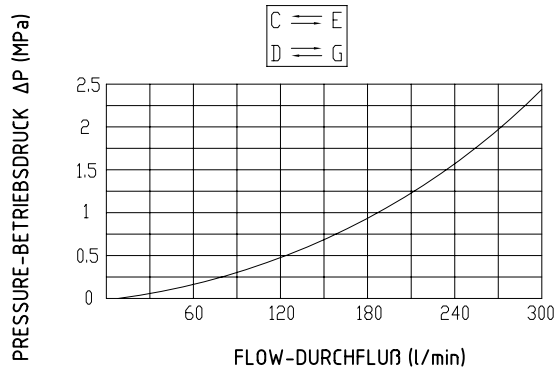
Diagram/Diagramm

PORT SIZE
GEWINDE

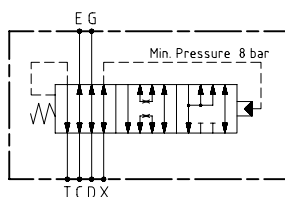
C, D, E, G	G 1" 1/4
T	G 1"
X	G 1/4"

764 GED-ED5-FW-300-114-7640

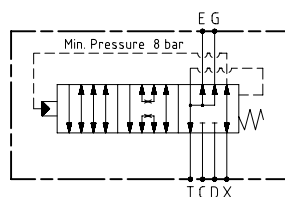
Weigth/Gewicht: 17.5 kg

755 GED-ED5-FW-300-114-7550

Weigth/Gewicht: 17.5 kg

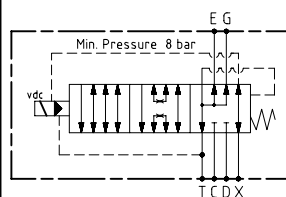
155 12V: GED-ED5-FW-300-114-1551
 24V: GED-ED5-FW-300-114-1552

Weigth/Gewicht: 17.7 kg

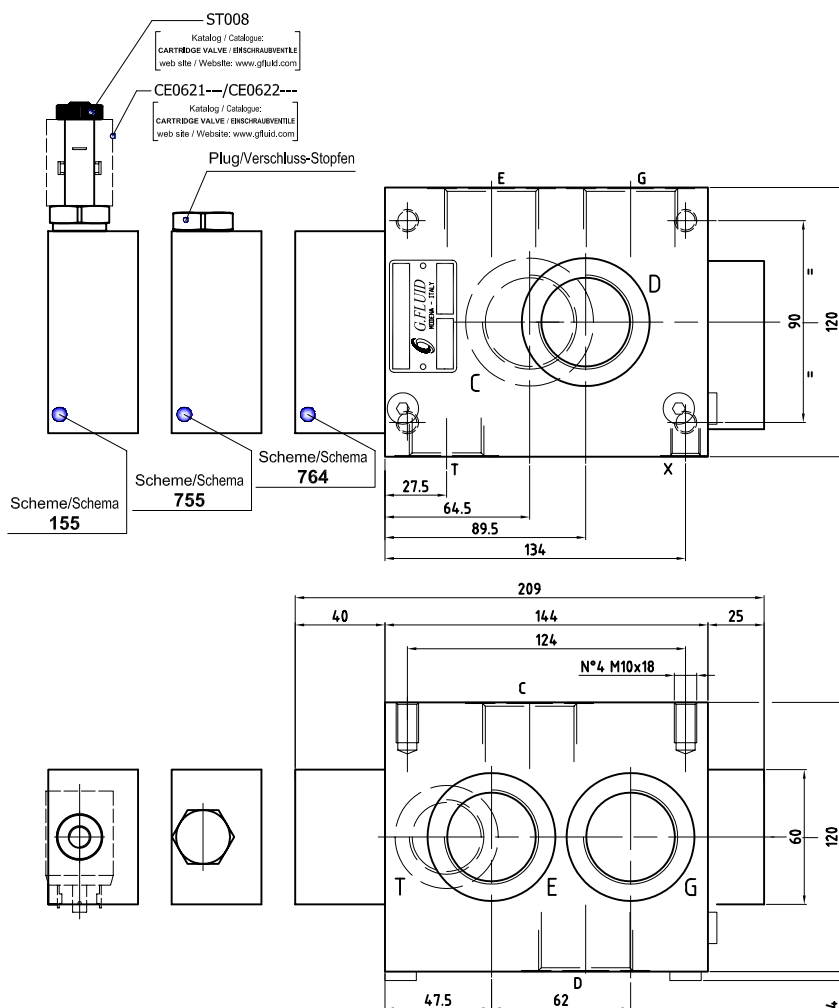
ORDERING INSTRUCTIONS - BESTELLANLEITUNG
1646 0 060

	Scheme/Schema	Voltage/Spannung
764	GED-ED5-FW-300-114-7640	0 only scheme/nur Schema: 755/764
755	GED-ED5-FW-300-114-7550	1 12 VDC (only scheme/nur Schema: 155)
155	GED-ED5-FW-300-114-155_	2 24 VDC (only scheme/nur Schema: 155)

TECHNICAL DATA
TECHNISCHE ANGABEN

Max operating pressure Maximaler Betriebsdruck	42 MPa 5973 psi
Max flow Volumenstrom	300 l/min 79.2 gpm
Max pressure on P1-P2 Maximaler Betriebsdruck auf P1-P2	min. 2 MPa - 290 psi max. 5 MPa - 725 psi
Temperature range Betriebstemperatur	-20°/80°C
Filtration Filtergrad	40µ
Weight Gewicht	7.5 kg
Material Material	Zinc coated Steel Verzinkter Stahl

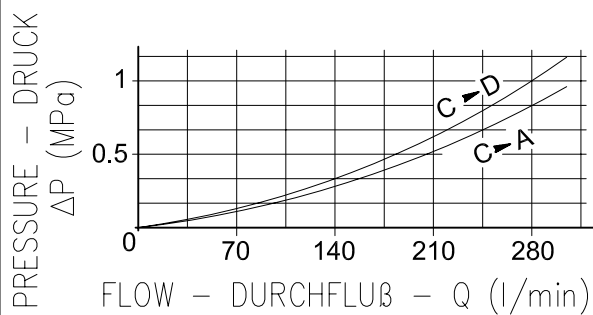
Diagram/Diagramm

PORT SIZE
GEWINDE

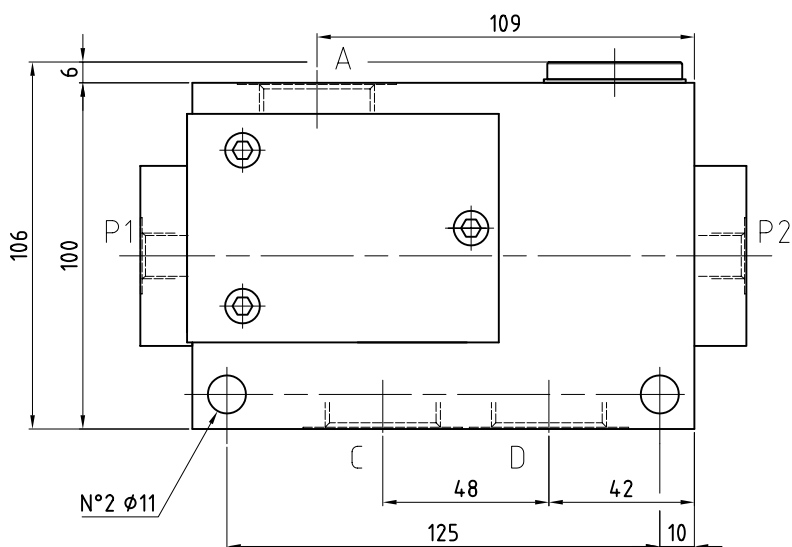
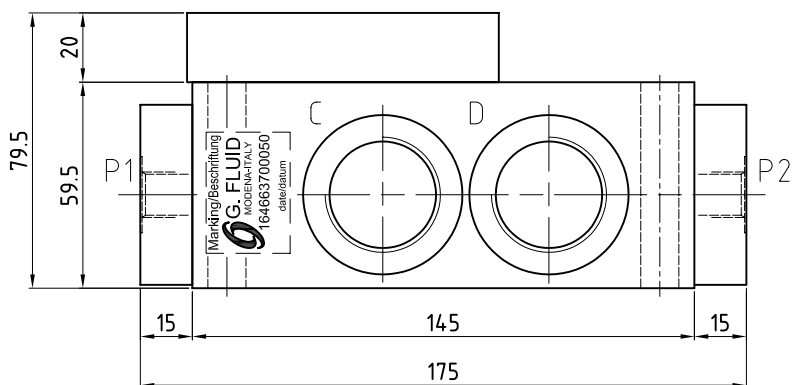
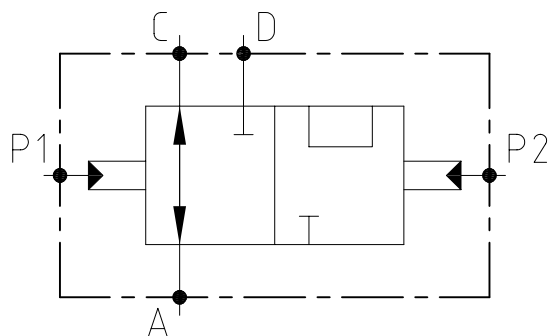
A, C, D	G 1"
P1, P2	G 1/4"

ORDERING INSTRUCTIONS - BESTELLANLEITUNG
16 46 63 70 00 50

**TECHNICAL DATA
 TECHNISCHE ANGABEN**

Max operating pressure Maximaler Betriebsdruck	31 MPa 4400 psi
Max flow Volumenstrom	250 l/min 66 gpm
Temperature range Betriebstemperatur	-20°/80°C
Filtration Filtergrad	40µ
Weight/Material Gewicht/Material	13 kg
Material Material	Zinc coated Steel Verzinkter Stahl

Deceleration valves are 2-way valves with two operating positions. The oil flow is controlled by a roller or roller/lever operated throttling spool, thus giving stroke related deceleration or acceleration of hydraulically moved masses. The check valve gives free return flow of the oil from B to A. A secondary flow throttle for the adjustment of a small secondary flow with the throttling spool in the closed position is incorporated in all models.

Verzögerungsventile sind 2-Wegeventile mit 2 stufenlos überlaufenden Schaltstellungen. Ein über Rolle oder Rollengeber betätigter Drosselkolben beeinflusst den Ölstrom. Somit erreicht man eine wegabhängige Verzögerung oder Beschleunigung hydraulisch bewegter Massen. Das Rückschlagventil dient zum freien Rücklauf des Ölstromes von B nach A.

Eine Nebenstromdrossel zum Einstellen eines kleinen Nebenstroms bei geschlossenem Drosselkolben ist in jeder Ausführung eingebaut.

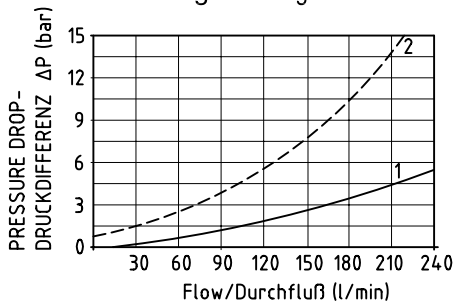
Diagram/Diagramm

Curve 1: flow from B to A via check valve with open throttle
 Kurve 1: Durchfluß von B nach A über das Rückschlagventil bei geöffnetem Drosselkolben

Curve 2: flow from B to A via check valve with closed throttle
 Kurve 2: Durchfluß von B nach A über das Rückschlagventil bei geschlossenem Drosselkolben

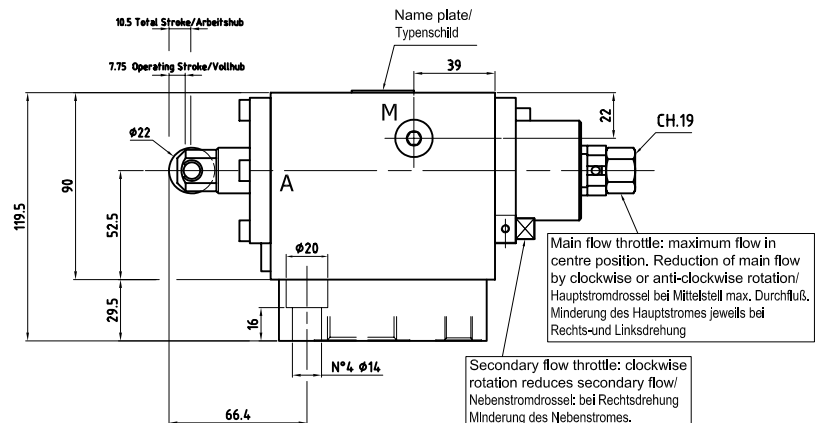
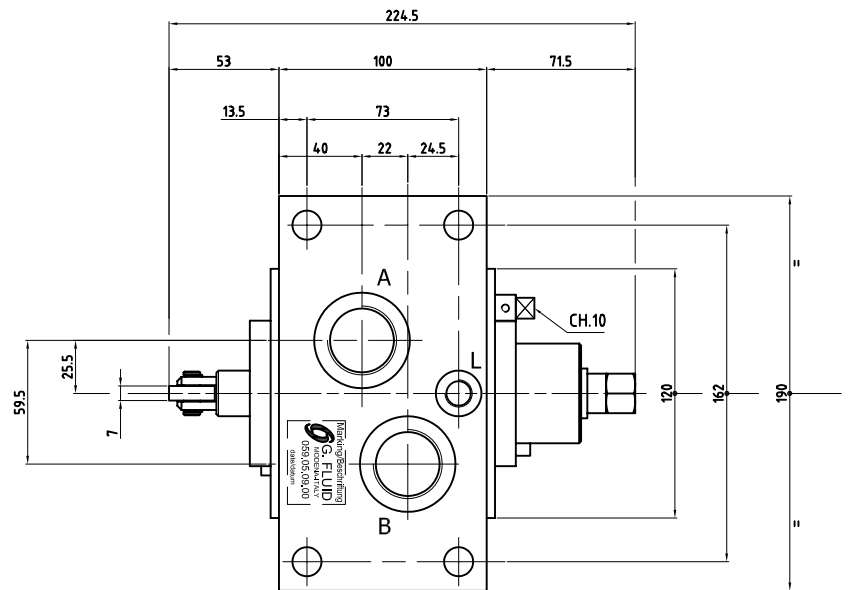
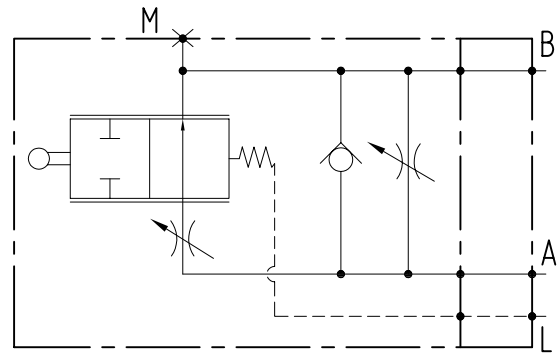

**PORT SIZE
 GEWINDE**

A, B	G 1"
M, L	G 1/4"

**ORDERING INSTRUCTIONS -
 BESTELLANLEITUNG**
059.05.09.00

**TECHNICAL DATA
 TECHNISCHE ANGABEN**

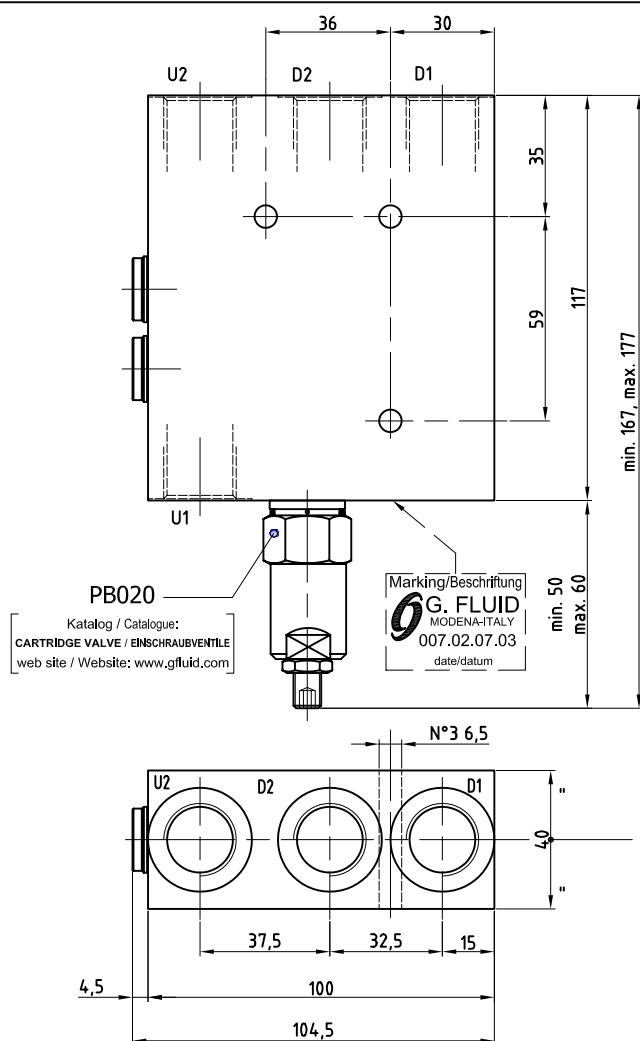
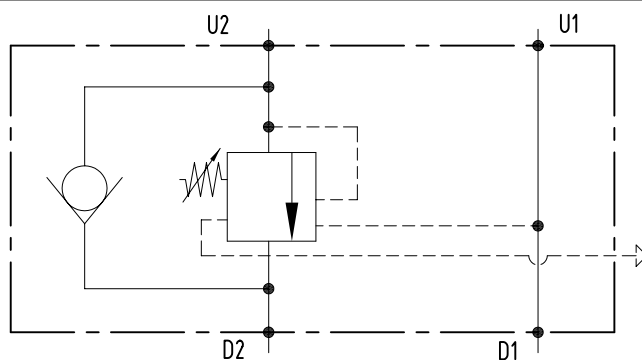
Max operating pressure Maximaler Betriebsdruck	35 MPa 5076 psi
Max flow Volumenstrom	60 l/min 18.5 gpm
Temperature range Betriebstemperatur	-20°/80°C
Filtration Filtergrad	40µ
Weight Gewicht	3.8 kg
Material	Zincoated Steel Verzinkter Stahl
Pilot ratio Steuerverhältnis	10:1



**PORT SIZE
 GEWINDE**

D1, D2, U1, U2	G 1/2"

**ORDERING INSTRUCTIONS -
 BESTELLANLEITUNG**
007.02.07.03

**TECHNICAL DATA
 TECHNISCHE ANGABEN**

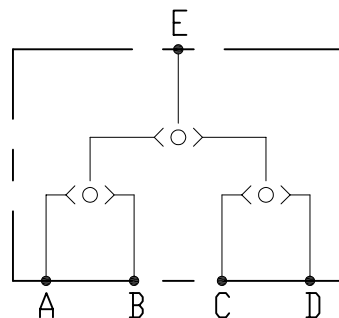
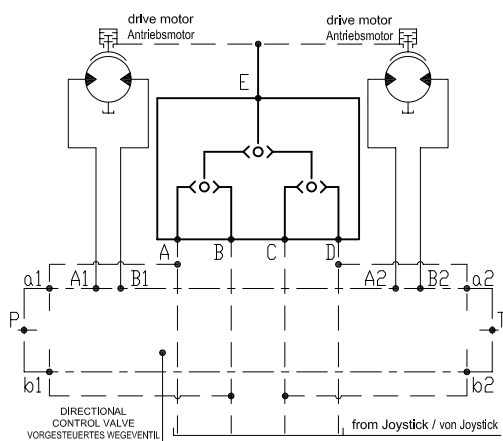
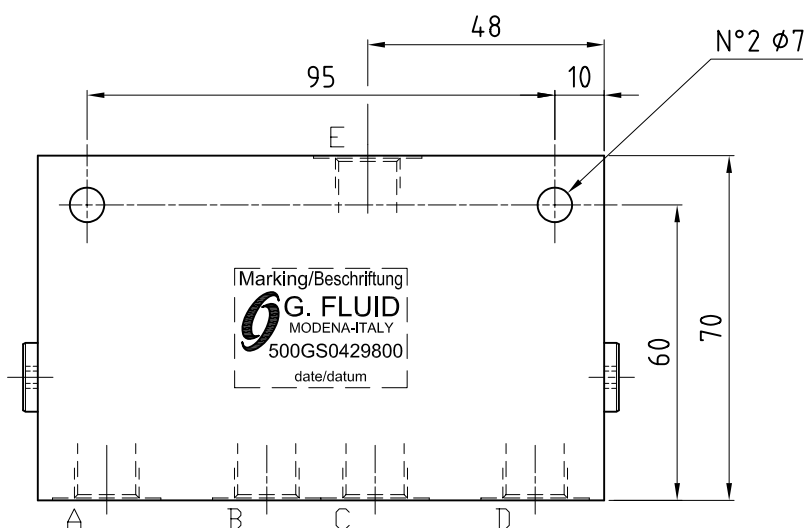
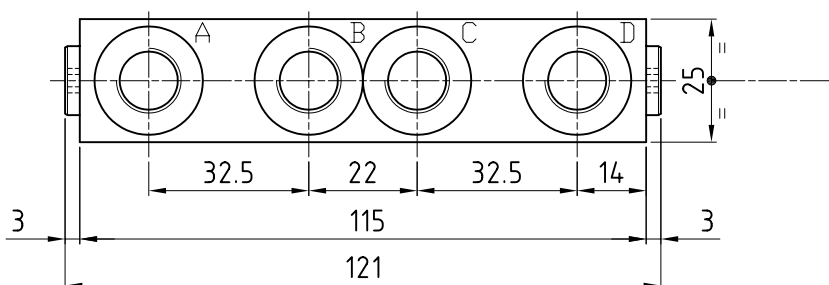
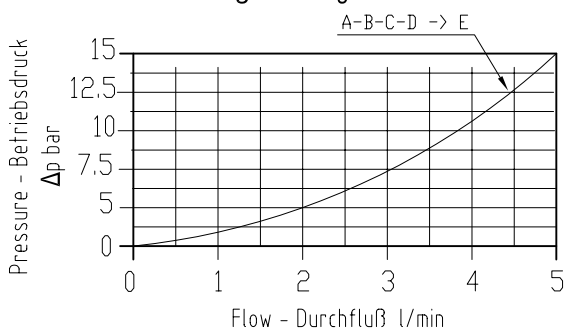
Max operating pressure Maximaler Betriebsdruck	25 MPa 3555 psi
Max flow Volumenstrom	5 l/min 1.3 gpm
Temperature range Betriebstemperatur	-20°/80°C
Filtration Filtergrad	40µ
Weight Gewicht	0.5 kg
Material	Alloy Aluminium
Port size Gewinde	A, B, C, D, E: 1/4" bspp

APPLICATION/ANWENDUNG

Diagram/Diagramm

ORDERING INSTRUCTIONS - BESTELLANLEITUNG
500GS0429800

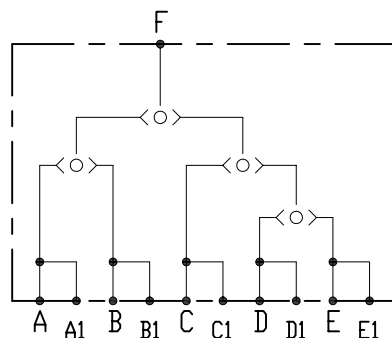
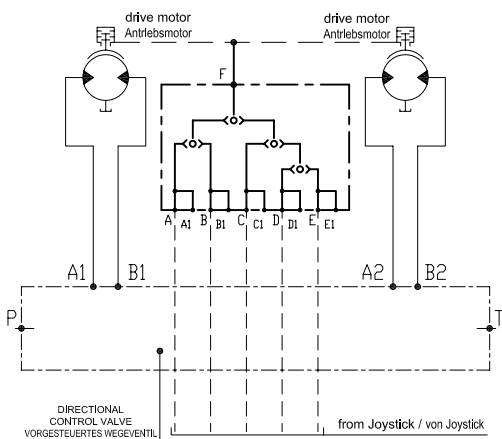
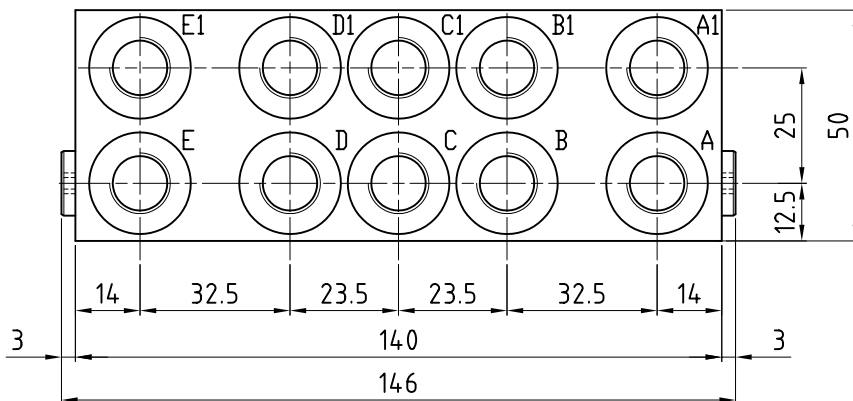
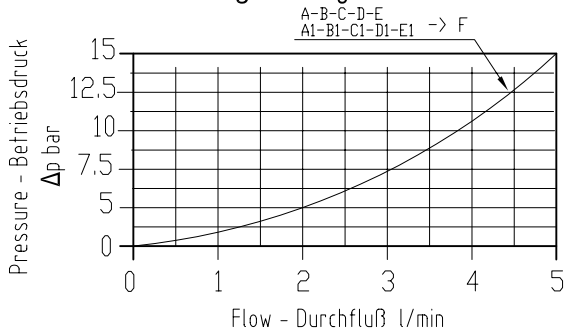
**TECHNICAL DATA
 TECHNISCHE ANGABEN**

Max operating pressure Maximaler Betriebsdruck	25 MPa 3555 psi
Max flow Volumenstrom	5 l/min 1.3 gpm
Temperature range Betriebstemperatur	-20°/80°C
Filtration Filtergrad	40µ
Weight Gewicht	1.3 kg
Material	Alloy Aluminium
Port size Gewinde	A, B, C, D, E, F A1, B, B1 C1, D1, E1: 1/4" bspp

APPLICATION/ANWENDUNG

Diagram/Diagramm

Marking/Beschriftung

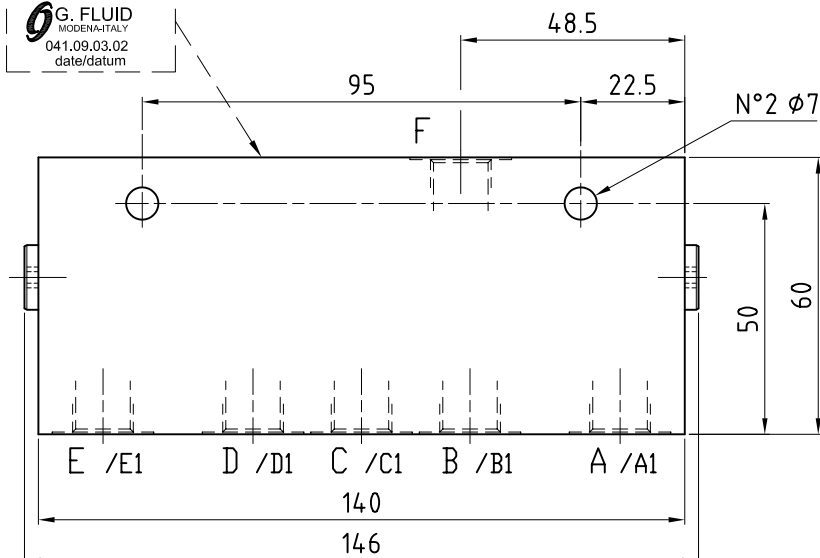
G. FLUID
 MODENA-ITALY
 041.09.03.02
 date/datum

ORDERING INSTRUCTIONS - BESTELLANLEITUNG
041.09.03.02

**TECHNICAL DATA
 TECHNISCHE ANGABEN**

Max operating pressure Maximaler Betriebsdruck	35 MPa 5076 psi
Max flow Volumenstrom	50 l/min 13.2 gpm
Temperature range Betriebstemperatur	-20°/80°C
Filtration Filtergrad	40µ

Diagram/Diagramm

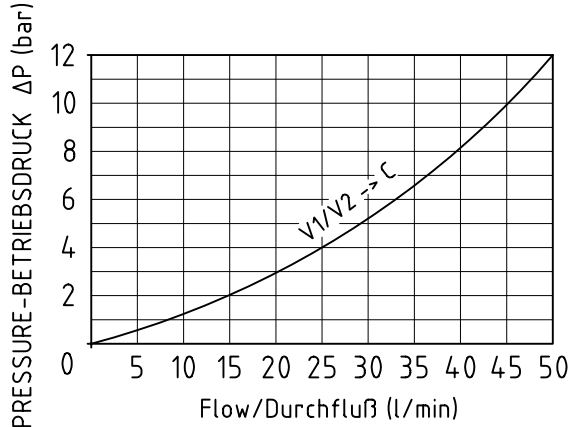
**PORT SIZE
 GEWINDE**

V1, V2, C	G 1/4"

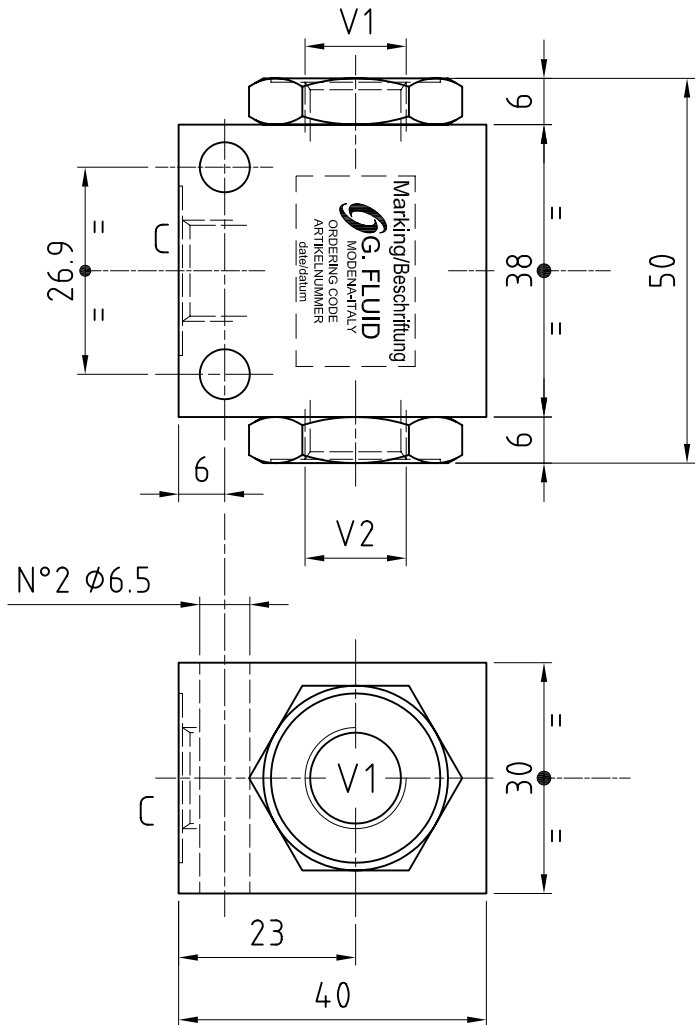
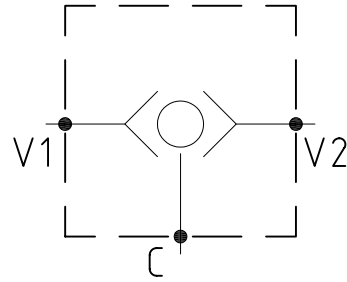

ORDERING CODE - ARTIKELNUMMER
1145059410 0

	Material Material	Weigth Gewicht
0	Alloy/Aluminium	0.2 kg
1	Zincoated Steel Verzinkter Stahl	0.4 kg

GVS-SB010-PIRM-042-NEU

**TECHNICAL DATA
 TECHNISCHE ANGABEN**

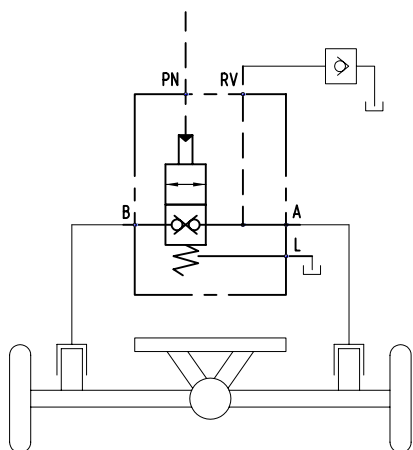
Max operating pressure Maximaler Betriebsdruck	42 MPa 6091 psi
Max flow Volumenstrom	10 l/min 2.6 gpm
Temperature range Betriebstemperatur	-20°/80°C
Filtration Filtergrad	40µ
Weight Gewicht	4 kg
Material Material	Zinc coated Steel Verzinkter Stahl

APPLICATION/ANWENDUNG

**PORT SIZE
 GEWINDE**

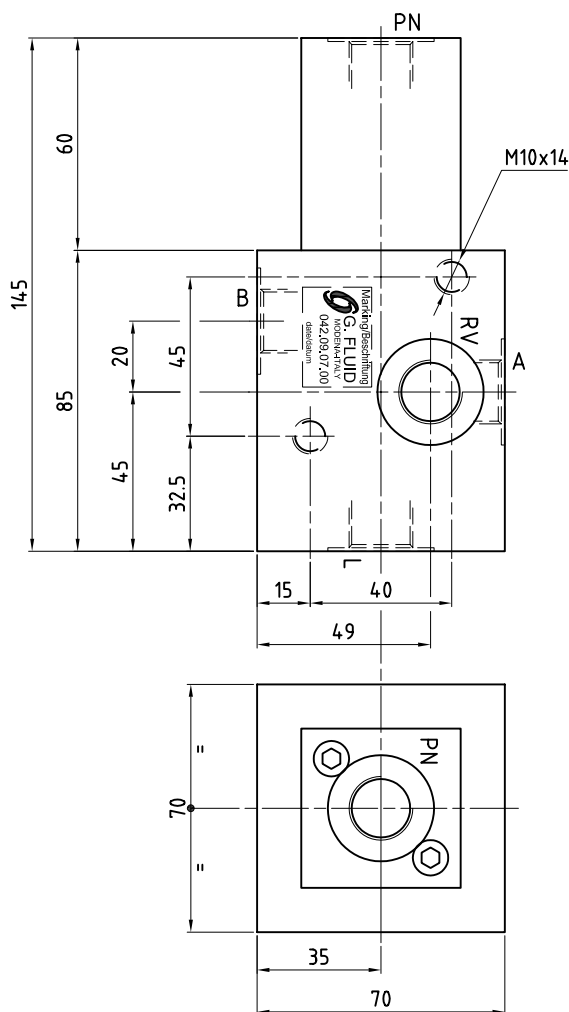
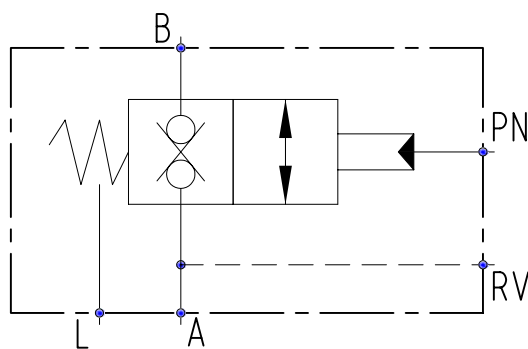
A, B, PN, RV, L	M18x1.5

ORDERING INSTRUCTIONS - BESTELLANLEITUNG
042.09.07.00

GRF-VPS-12

TECHNICAL DATA TECHNISCHE ANGABEN

Max operating pressure Maximaler Betriebsdruck	35 MPa 5076 psi
Max flow Volumenstrom	40 l/min 10.6 gpm
Temperature range Betriebstemperatur	-20°/80°C
Filtration Filtergrad	40µ
Weight Gewicht	2.3 kg
Material Material	Zincoated Steel Verzinkter Stahl

APPLICATION/ANWENDUNG

The Priority Valves distribute and trace the hydraulic flow from the supply pump of the hydraulic system to the hydraulic components which control and run the vehicle. The Priority Valves are used only with the hydrostatic steering units. When connected, the steering unit and the priority valve represent sophisticated hydraulic tracing system that controls the flow in both main pipelines of the hydraulic system (the working and control one) at any time of its operation.

Das Prioritätsventil wird über LS-Signal vom Lenkaggregat derart geregelt, daß sich Ölstrom zum Lenkaggregat ständig an den jeweilige Bedarf anpaßt. Die jeweilige Restmenge steht der Arbeitshydraulik zur Verfügung. Ein Vorteil ist die optimale Ausnutzung der Pumpenleistung - bei nicht betätigter Lenkung kann die Arbeitshydraulik mit vollem Volumenstrom versorgt werden.

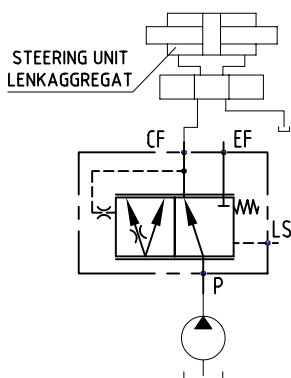

PORT SIZE/GEWINDE

P, CF, EF	G 1/2"
LS	G 1/4"

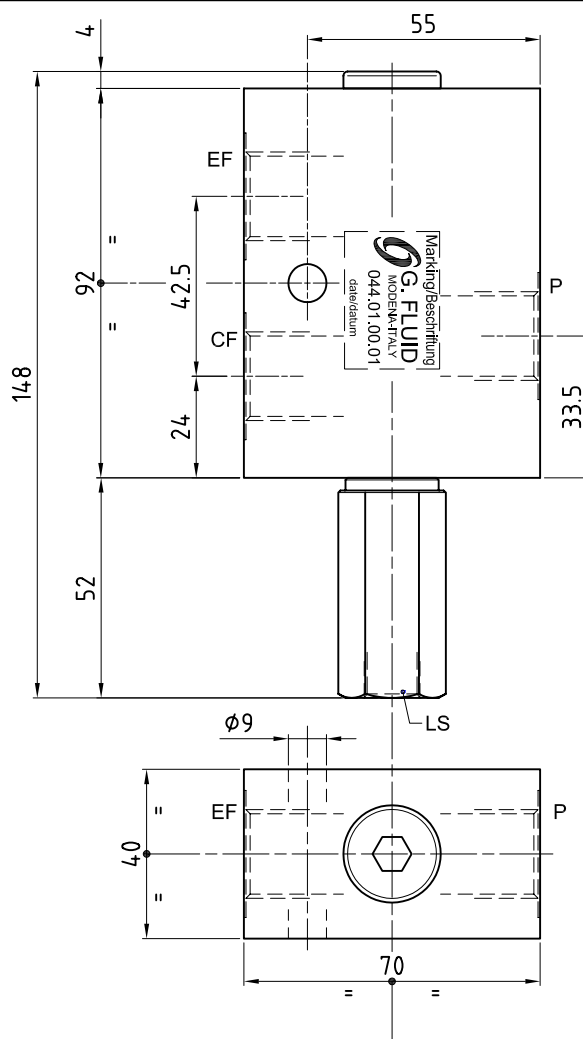
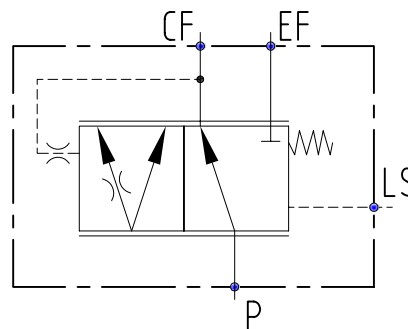

ORDERING INSTRUCTIONS - BESTELLANLEITUNG

044.01.00.01

GRF-VPS-12F

TECHNICAL DATA TECHNISCHE ANGABEN

Max operating pressure Maximaler Betriebsdruck	35 MPa 5076 psi
Max flow Volumenstrom	40 l/min 10.6 gpm
Temperature range Betriebstemperatur	-20°/80°C
Filtration Filtergrad	40µ
Weight Gewicht	2.3 kg
Material Material	Zincoated Steel Verzinkter Stahl

APPLICATION/ANWENDUNG

The Priority Valves distribute and trace the hydraulic flow from the supply pump of the hydraulic system to the hydraulic components which control and run the vehicle. The Priority Valves are used only with the hydrostatic steering units. When connected, the steering unit and the priority valve represent sophisticated hydraulic tracing system that controls the flow in both main pipelines of the hydraulic system (the working and control one) at any time of its operation.

Das Prioritätsventil wird über LS-Signal vom Lenkaggregat derart geregelt, daß sich Ölstrom zum Lenkaggregat ständig an den jeweilige Bedarf anpaßt. Die jeweilige Restmenge steht der Arbeitshydraulik zur Verfügung. Ein Vorteil ist die optimale Ausnützung der Pumpenleistung - bei nicht betätigter Lenkung kann die Arbeitshydraulik mit vollem Volumenstrom versorgt werden.

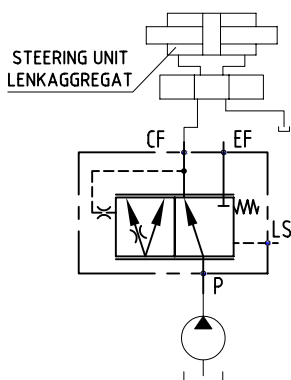

PORT SIZE/GEWINDE

CF, EF	G 1/2"
LS	G 1/4"

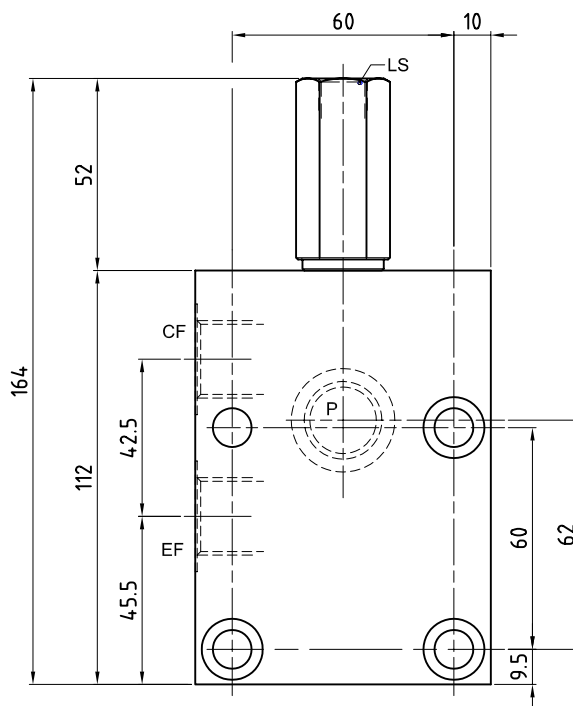
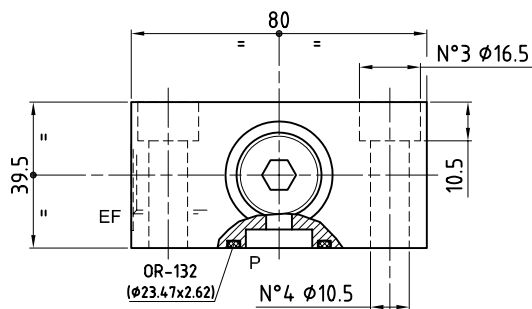
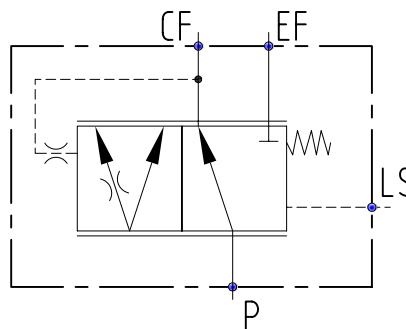

ORDERING INSTRUCTIONS - BESTELLANLEITUNG

030.07.12.00

GVD-3V-SCS-18

TECHNICAL DATA
TECHNISCHE ANGABEN

Max operating pressure Maximaler Betriebsdruck	42 MPa 6091 psi
Max flow Volumenstrom	3 l/min 0.79 gpm
Temperature range Betriebstemperatur	-20°/80°C
Filtration Filtergrad	40μ
Weight Gewicht	0.24 kg
Material Material	Zincoated Steel Verzinkter Stahl

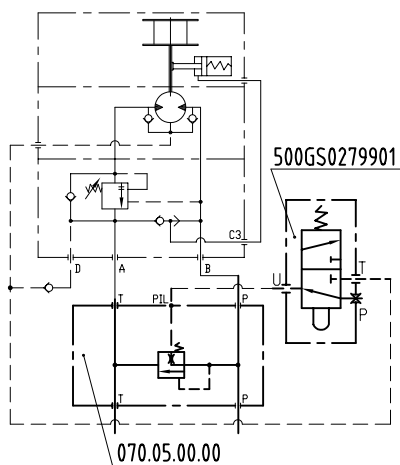
APPLICATION/ANWENDUNG

PORT SIZE/GEWINDE

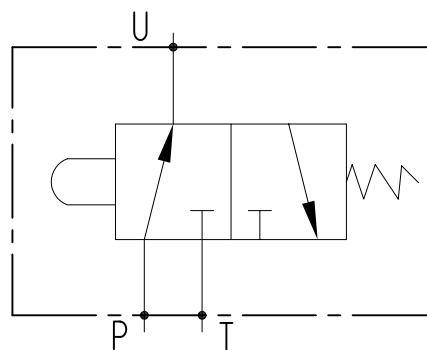
U, P, T	M18x1.5
---------	---------

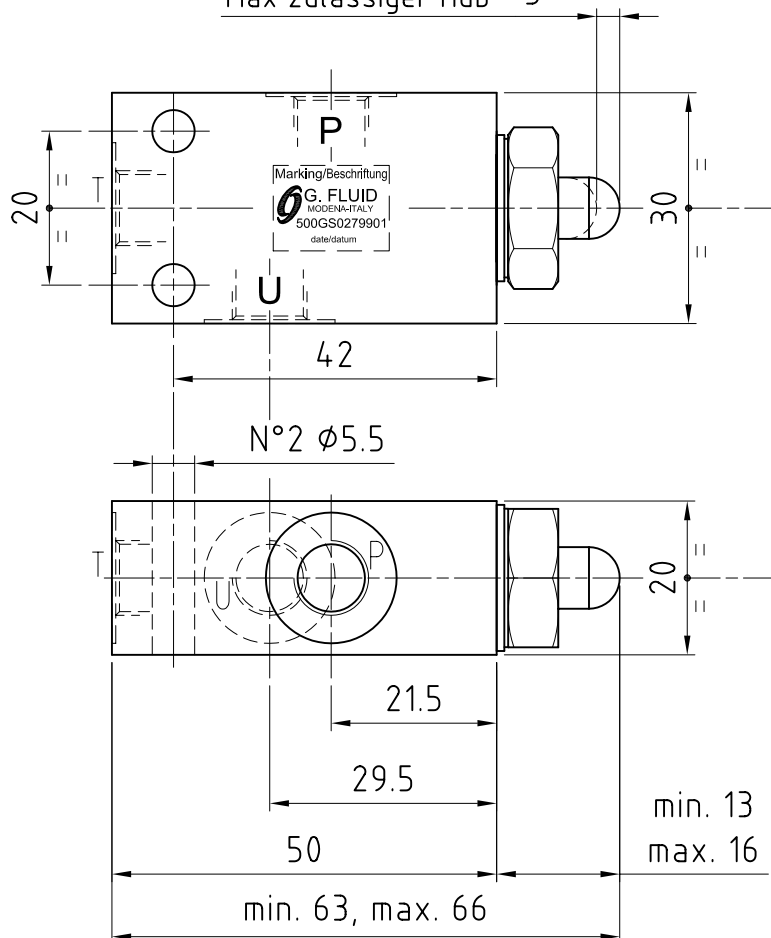

Max allowed stroke

Max zulässiger Hub 3

ORDERING INSTRUCTIONS - BESTELLANLEITUNG
500GS0279901

GVR-CP-C115G-12-18-TMA

TECHNICAL DATA
TECHNISCHE ANGABEN

Max operating pressure Maximaler Betriebsdruck	25 MPa 3626 psi
Max flow Volumenstrom	40 l/min 10.6 gpm
Temperature range Betriebstemperatur	-20°/80°C
Filtration Filtergrad	40µ
Weight Gewicht	0.5 kg
Material Material	Alloy Aluminium

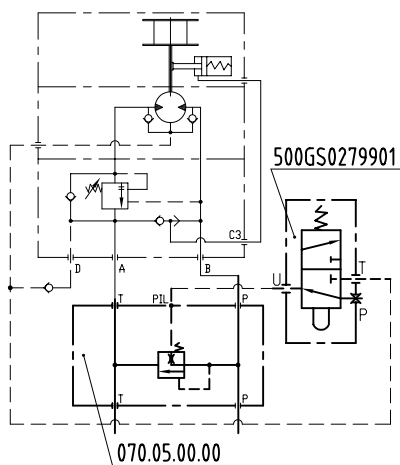
APPLICATION/ANWENDUNG

PORT SIZE/GEWINDE

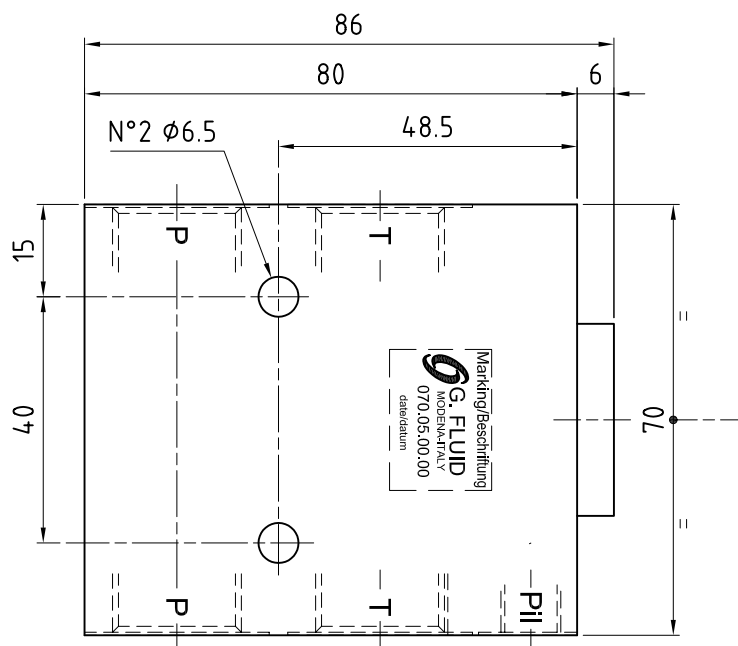
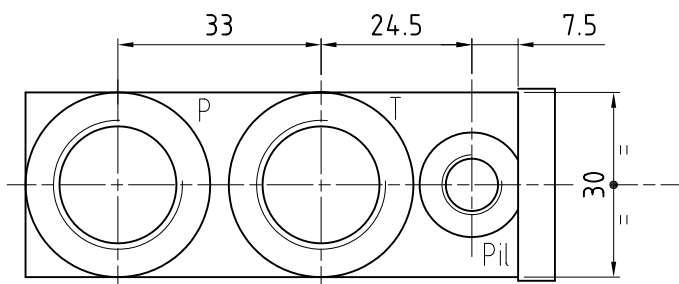
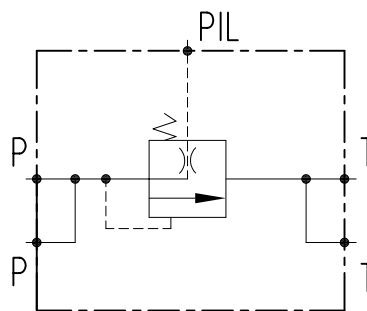
T, T, P, P	M18x1.5
Pil	G 1/8"

ORDERING INSTRUCTIONS - BESTELLANLEITUNG
070.05.00.00

TECHNICAL DATA
TECHNISCHE ANGABEN

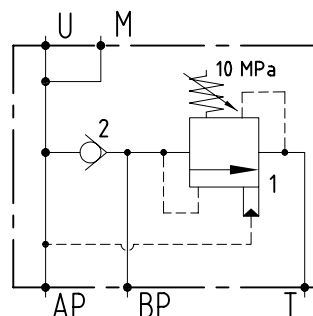
Max operating pressure Maximaler Betriebsdruck	35 MPa 5076 psi
Max flow Volumenstrom	70 l/min 18.5 gpm
Temperature range Betriebstemperatur	-20°/80°C
Filtration Filtergrad	40µ
Material/Material Weight/Gewicht	ZIncoated Steel/Verzinkter Stahl 2.8 kg

APPLICATION/ANWENDUNG

This valve is used in a 2 parallel-working pumps circuit in order to release the excess of the higher flow pump to the tank when it reaches the required pressure setting. From this moment the actuator works with the lower flow pump at higher pressure, consuming less energy.

Dieses Ventil wird in einem Kreislauf, in dem zwei Pumpen parallel arbeiten, verwendet, um den Überschuss der Pumpe mit dem höheren Durchfluß zum Tank freizugeben, wenn eine bestimmte Druckeinstellung erreicht wird. Ab diesem Zeitpunkt arbeitet der Antrieb mit der Pumpe mit geringerem Durchfluß bei höherem Druck und verbraucht so weniger Energie.

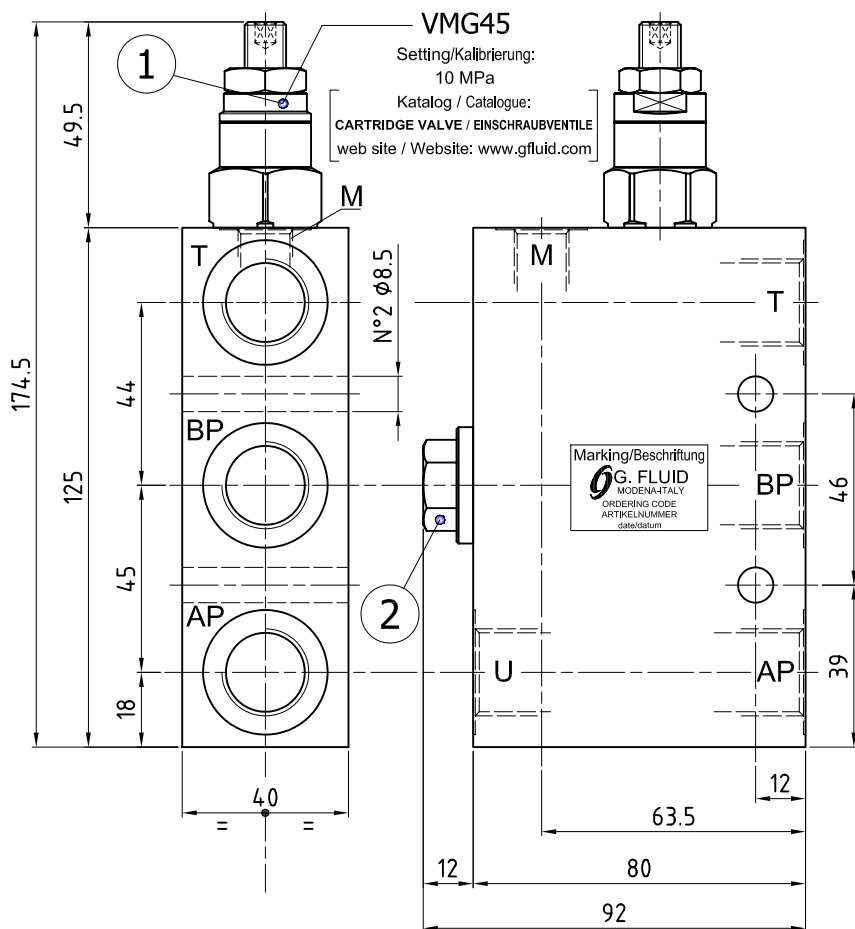
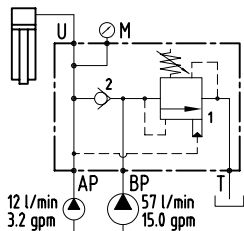
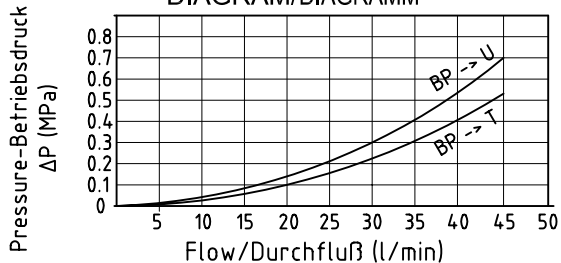

DIAGRAM/DIAGRAMM

PORT SIZE/GEWINDE

T, BP, AP, U	G 1/2"
M	G 1/4"

ORDERING CODE - ARTIKELNUMMER
038.09.12.00

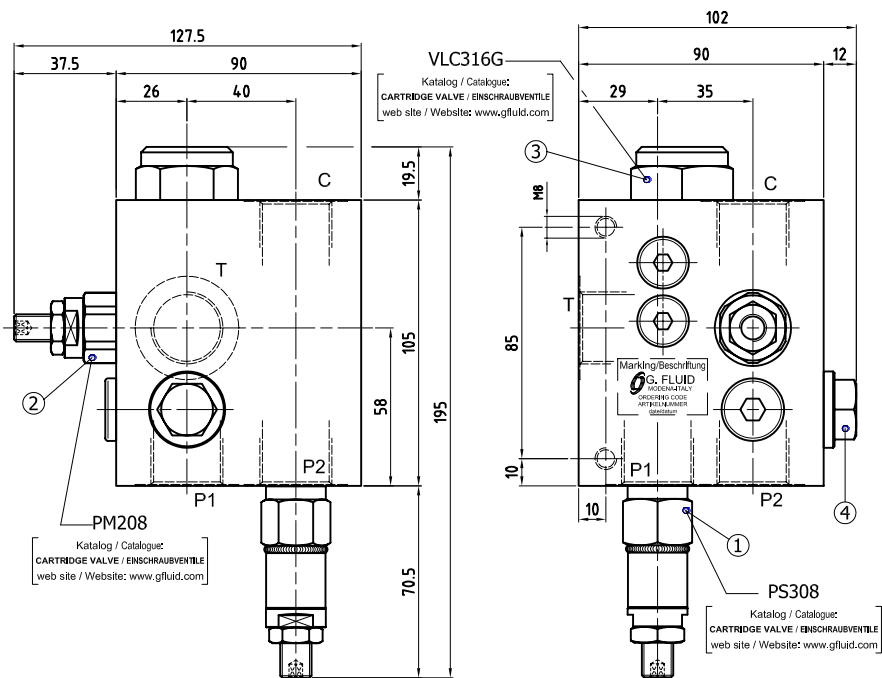
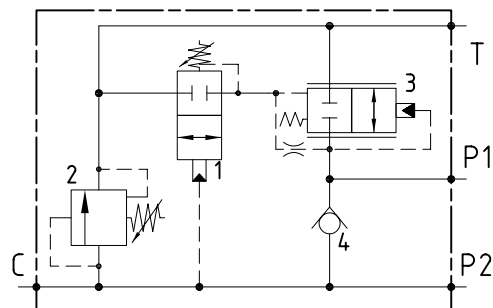
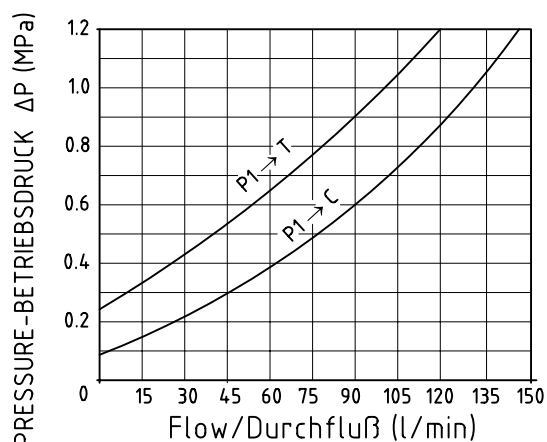
TECHNICAL DATA
TECHNISCHE ANGABEN

Max operating pressure P1 Maximaler Betriebsdruck P1	10 MPa 1450 psi
Max operating pressure P2 Maximaler Betriebsdruck P2	35 MPa 5076 psi
Max flow (Valve 2) Volumenstrom (Ventile 2)	30 l/min 7.9 gpm
Temperature range Betriebstemperatur	-20°/80°C
Filtration Filtergrad	40µ

Diagram/Diagramm

ORDERING CODE - ARTIKELNUMMER
29001 0 0000

04	Port size/Gewinde P, T	1	Valve Ventile	Adj. range Regelbereich	std setting Standardeinst.	Pressure increase MPa/tum Drucksteigerung MPa je Schraubendrehung	0	Material Material	Weight Gewicht
	G 3/4"		1	2-10 MPa	10 MPa	1.7		Alloy Aluminium	2.5 kg
		2	2	5-21 MPa	18 MPa	2.3			
		1	1	2-10 MPa	10 MPa	1.7	1	Zincoated Steel/ Verzinkter Stahl	6.7 kg
		2	2	10-35 MPa	30 MPa	8.2			

GVE-SC-BF-38

TECHNICAL DATA TECHNISCHE ANGABEN

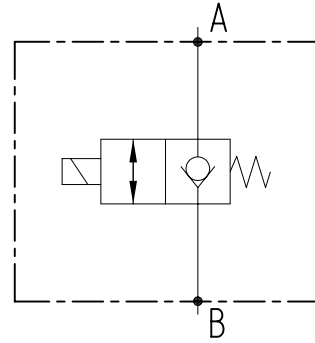
Max operating pressure Maximaler Betriebsdruck	25 MPa 3626 psi
Max flow Volumenstrom	30 l/min 7.9 gpm
Temperature range Betriebstemperatur	-20°/80°C
Filtration Filtergrad	40µ
Weigth Gewicht	0.25 kg
Material	Alloy Aluminium



BANJO BOLT 3/8" BSPP

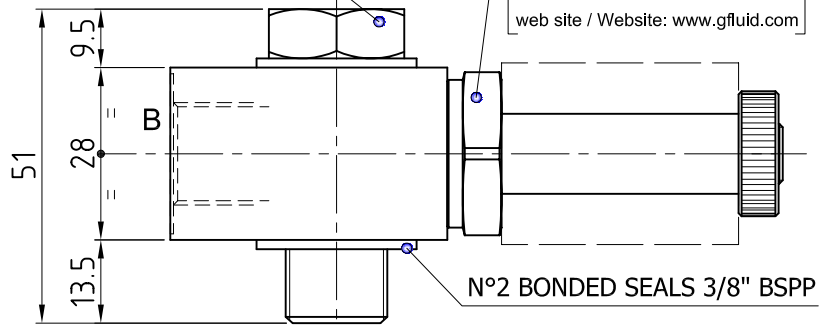

SC008

Katalog / Catalogue:
 CARTRIDGE VALVE / EINSCHRAUBVENTILE
 web site / Website: www.gfluid.com

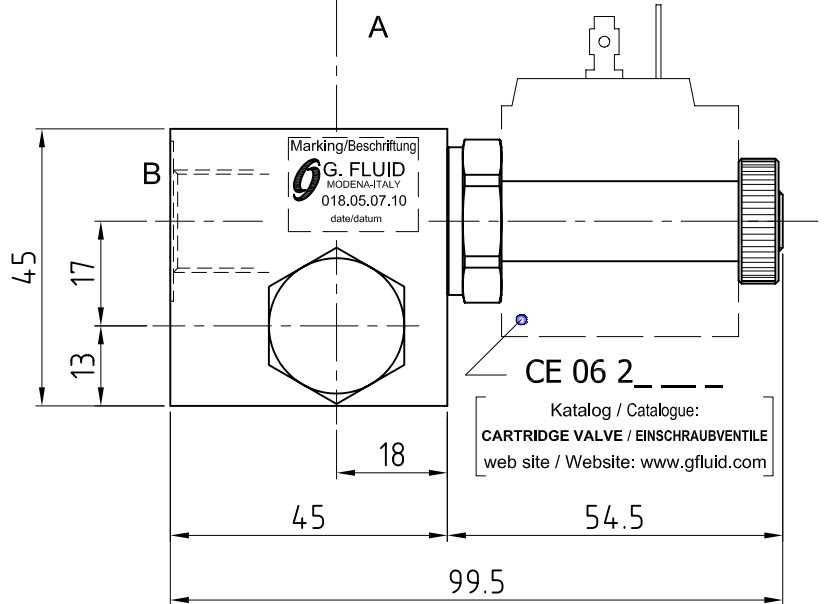

PORT SIZE/GEWINDE

B	G 3/8"

ORDERING INSTRUCTIONS - BESTELLANLEITUNG

018.05.07.10

GVE-SC-BF-EM-38

TECHNICAL DATA TECHNISCHE ANGABEN

Max operating pressure Maximaler Betriebsdruck	25 MPa 3626 psi
Max flow Volumenstrom	30 l/min 7.9 gpm
Temperature range Betriebstemperatur	-20°/80°C
Filtration Filtergrad	40μ
Weigth Gewicht	0.3 kg
Material	Alloy Aluminium

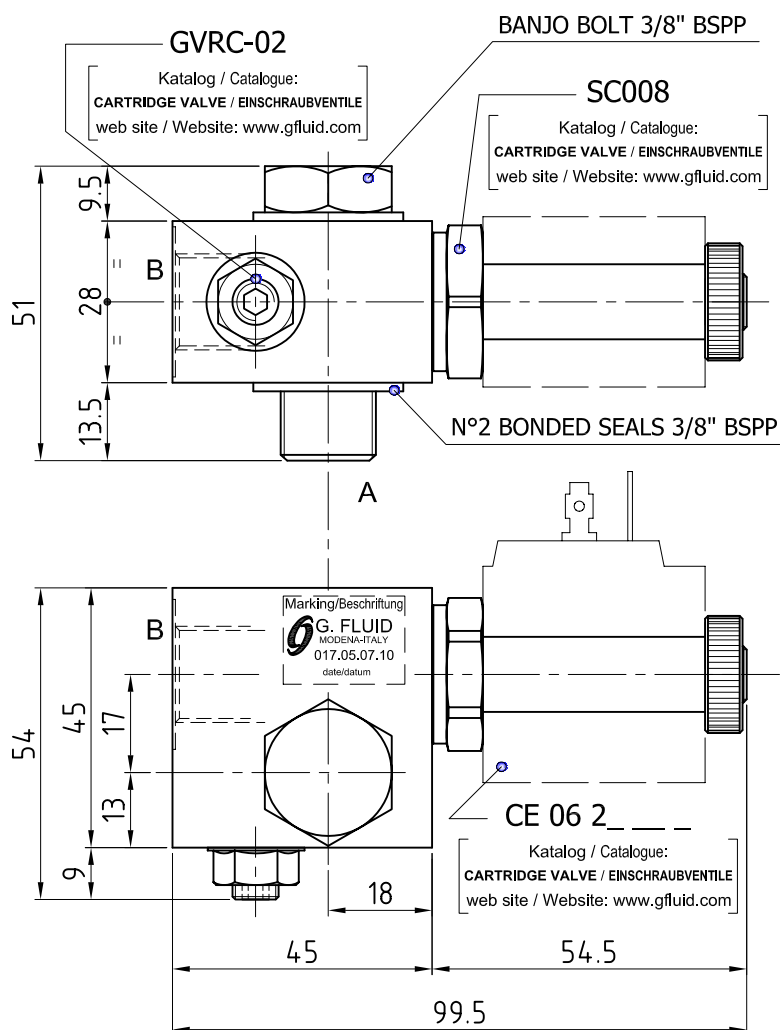
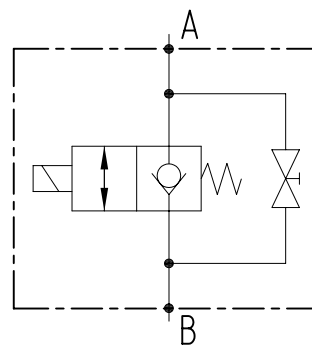

PORT SIZE/GEWINDE

B	G 3/8"

ORDERING INSTRUCTIONS - BESTELLANLEITUNG

017.05.07.10

GVE-SC-BF-EM-12

TECHNICAL DATA TECHNISCHE ANGABEN	
Max operating pressure Maximaler Betriebsdruck	25 MPa 3626 psi
Max flow Volumenstrom	30 l/min 7.9 gpm
Temperature range Betriebstemperatur	-20°/80°C
Filtration Filtergrad	40µ
Weigth Gewicht	0.35 kg
Material	Alloy Aluminium

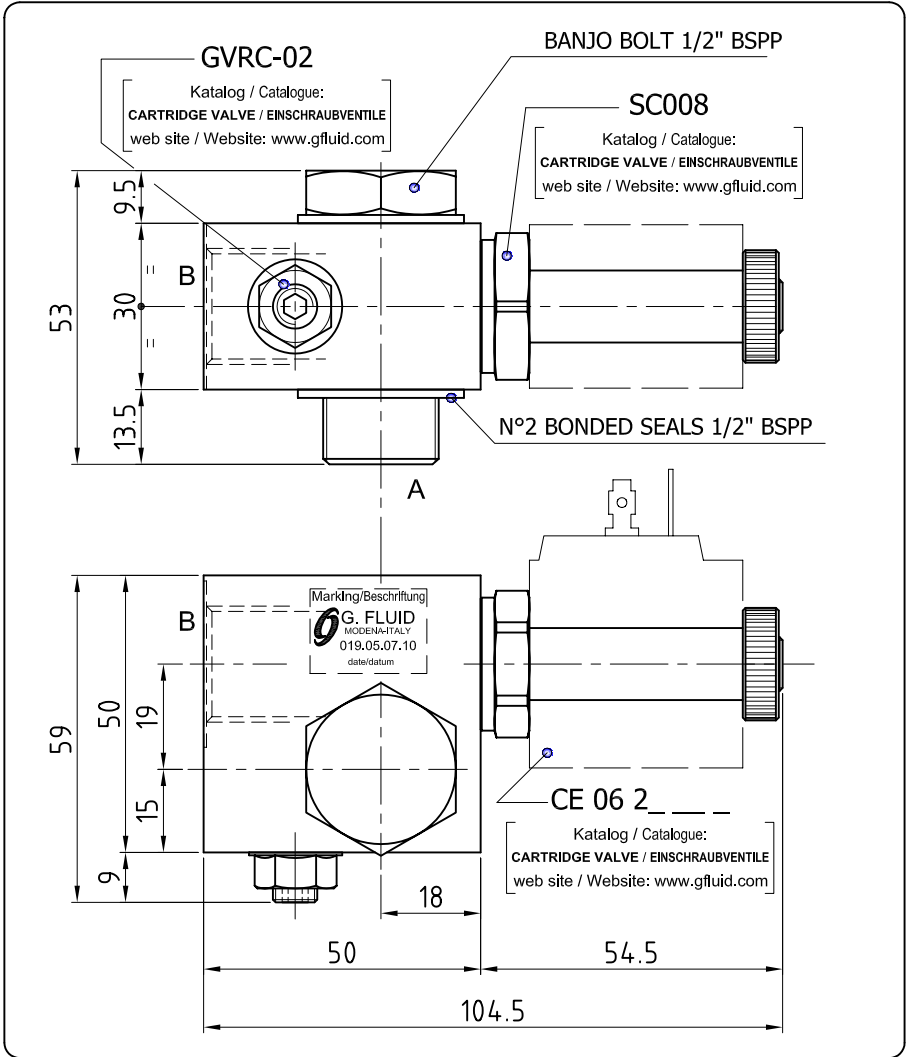
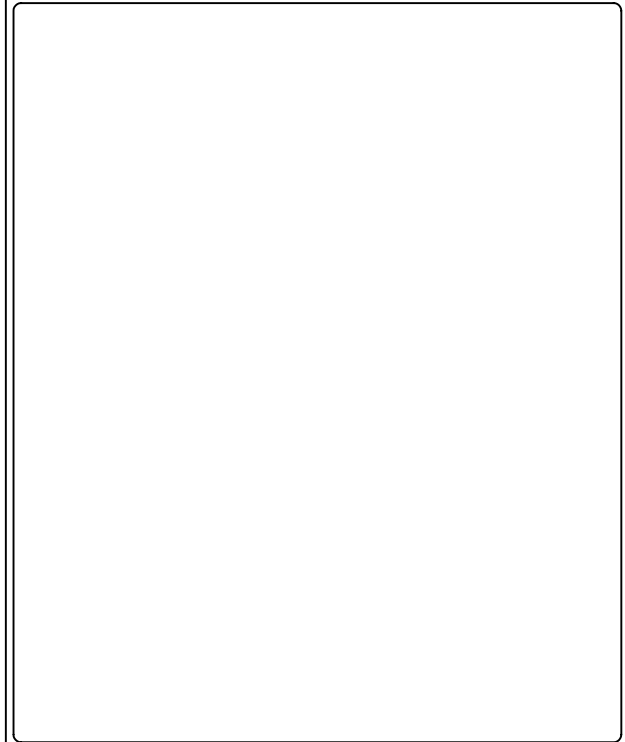
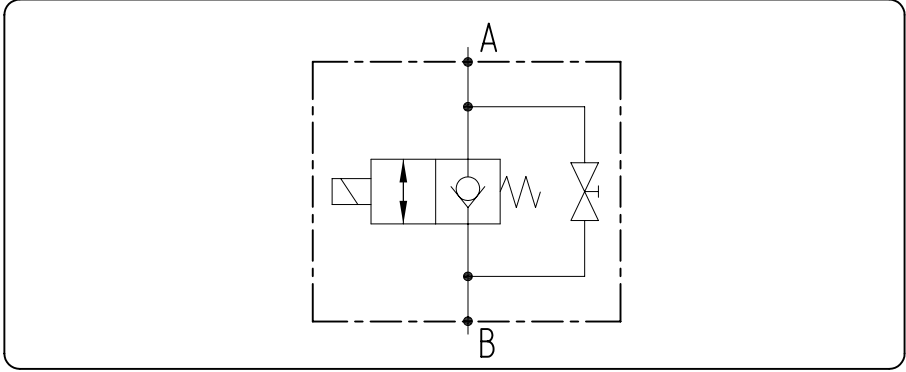

PORT SIZE/GEWINDE	
B	G 1/2"

ORDERING INSTRUCTIONS - BESTELLANLEITUNG

019.05.07.10

**TECHNICAL DATA
TECHNISCHE ANGABEN**

Max operating pressure Maximaler Betriebsdruck	35 MPa 5076 psi
Max flow Volumenstrom	40 l/min 10.6 gpm
Temperature range Betriebstemperatur	-20°/80°C
Filtration Filtergrad	40µ
Weight Gewicht	9.7 kg
Material Material	Zincoated Steel Verzinkter Stahl

APPLICATION/ANWENDUNG

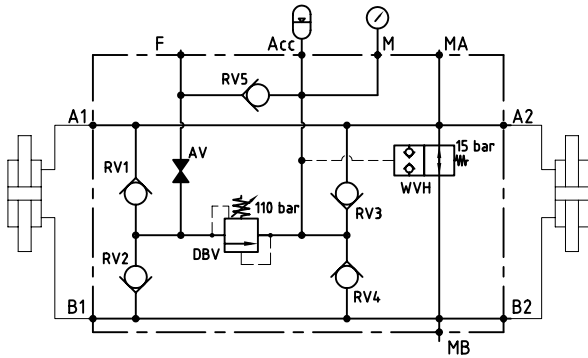

PORT SIZE/GEWINDE

A1, B1, A2, B2	G 3/8"
F, MA, MB	G 1/4"

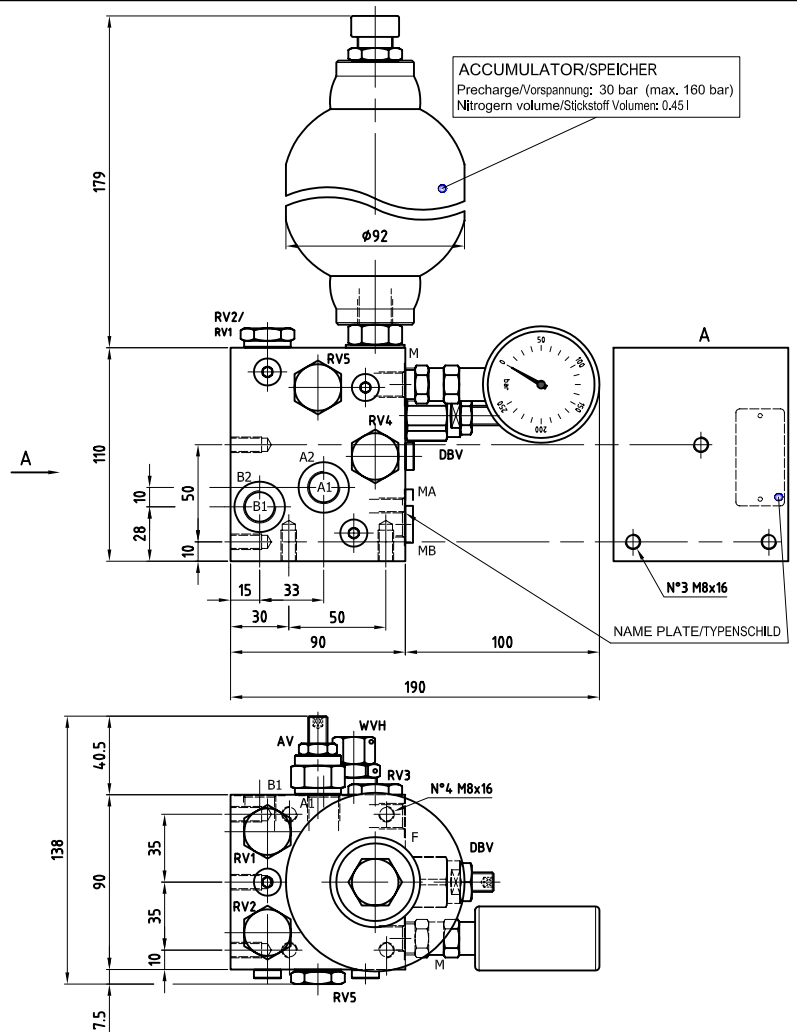
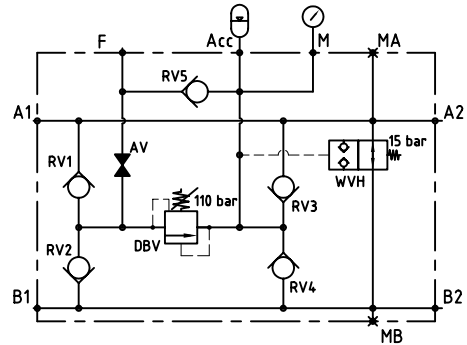

ORDERING INSTRUCTIONS - BESTELLANLEITUNG

005.02.11.04

TECHNICAL DATA TECHNISCHE ANGABEN

Max operating pressure Maximaler Betriebsdruck	25 MPa 3626 psi
Max flow Volumenstrom	30 l/min 7.9 gpm
Temperature range Betriebstemperatur	-20°/80°C
Filtration Filtergrad	40μ
Weight/Gewicht Material/Material	1 kg Alloy/Aluminium
Standard setting Standard Einstellung	P1=15 MPa
Pos. 1	empty trailer/leeren Anhänger
Pos. 2	half load/Halbe Beladung: P1 + 3 MPa
Pos. 3	full load/Vollast: P1 + 6 MPa

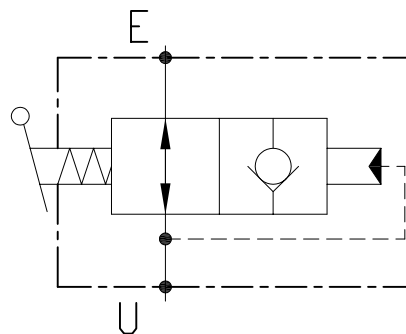

APPLICATION/ANWENDUNG

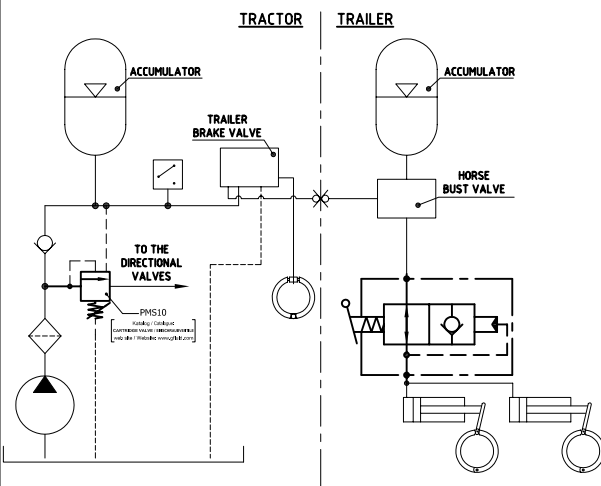

PORT SIZE/GEWINDE

U, E	G 1/2"

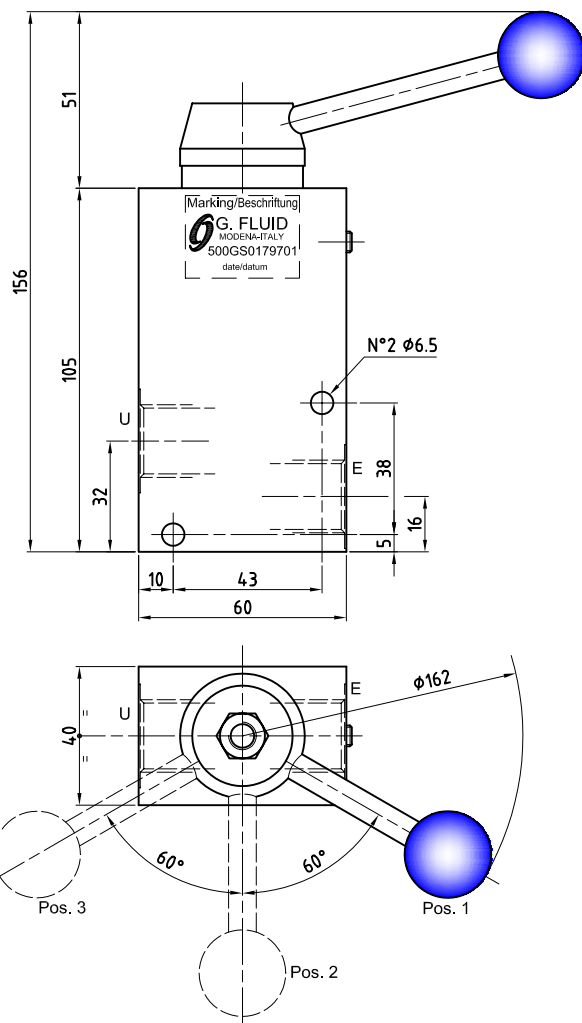

ORDERING INSTRUCTIONS - BESTELLANLEITUNG

500GS0179701

LENGTH LÄNGE		
1 m	=	39.3701 in
	=	3.2808 ft
	=	1.0936 yd
	=	1000 mm
1 in	=	0.0833 ft
	=	25.4 mm
1 ft	=	0.3048 m
	=	0.3333 yd
	=	12 in
1 yd	=	0.9144 m
	=	3 ft
	=	36 in
1 km	=	1000 m
	=	1093.6 yd
	=	0.6214 mile
1 mile	=	1.609 km
	=	1760 yd

MASS GEWICHT		
1 kg	=	2.2046 lb
1 lb	=	0.4536 kg

SPEED GESCHWINDIGKEIT		
1 m/s	=	3.6 km/h
	=	2.237 mph
	=	3.2808 ft/s
1 km/h	=	0.2778 m/s
	=	0.6214 mph
	=	0.9113 ft/s
1 mph	=	1.609 km/h
	=	0.447 m/s
	=	1.467 ft/s
1 ft/s	=	0.3048 m/s
	=	1.0973 km/h
	=	0.6818 mph

FORCE KRAFT		
1 N	=	0.102 kgf
	=	0.2248 lbf
1 kgf	=	2.205 lbf
	=	9.806 N
1 lbf	=	0.4536 kgf
	=	4.448 N

PRESSURE DRUCK		
1 bar	=	14.223 psi
	=	0.99 atm
	=	1.02 ata
	=	100000 Pa
	=	100 kPa
	=	0.1 MPa
1 psi	=	0.0703 bar

FLOW DURCHFLUSS		
1 l/min	=	0.264 gpm
	=	1000 cc/min
1 gpm	=	3.785 l/min
	=	3785 cc/min
1 m ³ /s	=	60000 l/min
	=	15852 gpm

POWER LEISTUNG		
1 kW	=	1.341 HP
	=	1.3596 CV
1 HP	=	0.7457 Kw
	=	1.0139 CV

TORQUE DREHMOMENT		
1 Nm	=	0.102 kgm
	=	0.7376 lbf ft
1 kgm	=	9.806 Nm
	=	7.2325 lbf ft
1 lbf ft	=	0.1383 kgm
	=	1.3558 Nm

For more information about our products see the catalogues:
Weitere Informationen zu unseren Produkten finden Sie in den folgenden Katalogen:

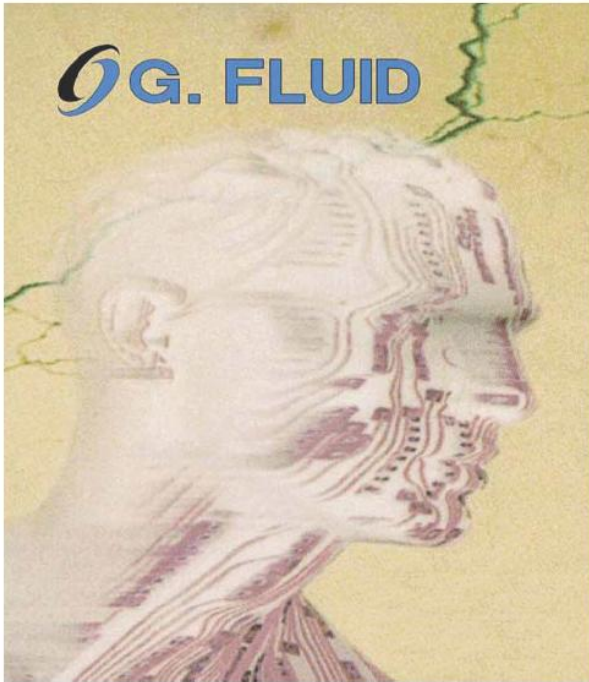
**CARTRIDGE VALVES
EINSCHRAUBVENTILE****VALVES FLANGEABLE**
*upon hydraulic motors***FLANSCHBARE VENTILE**
für Hydraulikmotoren



GUGLIELMI FLUIDODINAMICA APPLICATA

G.Fluid s.r.l.

Via Cesare della Chiesa 168/a - 41100 Modena - Italy

Tel +39 059 828543 - Fax +39 059 828547

www.gfluid.com - info@gfluid.com -

skype:

Mauro Guglielmi
Donatella Finelli
G.Fluid Carmen